

CITY OF SEATTLE

ORDINANCE _____

COUNCIL BILL _____

..title

AN ORDINANCE relating to the Seattle Mechanical Code; amending Section 22.400.010 of the Seattle Municipal Code and adopting by reference Chapters 2 through 9 and Chapters 11 through 16 of the 2015 International Mechanical Code with amendments; and adopting a new Chapter 1 related to administration, permitting, and enforcement; and repealing Sections 2 through 14 of Ordinance 124275.

..body

BE IT ORDAINED BY THE CITY OF SEATTLE AS FOLLOWS:

Section 1. Section 22.400.010 of the Seattle Municipal Code, last amended by Ordinance 124275, is amended as follows:

22.400.010 Adoption of International Mechanical Code and local amendments

The Seattle Mechanical Code consists of: (1) the following portions of the ~~((2012))~~ 2015 edition of the International Mechanical Code published by the International Code Council, as amended by the City Council by ordinance: Chapters 2 through 9, Chapters 11 through ~~((15))~~ 16, and (2) Chapter 1 relating to administration, permitting, and enforcement adopted by City Council ordinance. One copy of the ~~((2012))~~ 2015 International Mechanical Code is filed with the City Clerk in C.F. ~~((313187))~~ 319953.

1 Section 2. Chapter 1 of the Seattle Mechanical Code is adopted to read as follows:

2 **CHAPTER 1**

3 **ADMINISTRATION**

4 **SECTION 101**

5 **TITLE**

6 **101.1 Title.** These regulations shall be known as the “Seattle Mechanical Code,” may be cited as
7 such, and are referred to herein as “this code.” All references to the *International Mechanical*
8 *Code* contained in this code mean the *Seattle Mechanical Code*.

9 **SECTION 102**

10 **PURPOSE**

11 **102.1 Purpose.** The purpose of this code is to provide minimum standards to safeguard life or
12 limb, health, property and public welfare by regulating and controlling the design, construction,
13 installation, quality of materials, location, operation, and maintenance or use of heating,
14 ventilating, cooling, refrigeration systems, incinerators and other miscellaneous heat-producing
15 appliances within the City. The purpose of this code is to provide for and promote the health,
16 safety and welfare of the general public, and not to create or otherwise establish or designate any
17 particular class or group of persons who will or should be especially protected or benefited by
18 the terms of this code.

19 **SECTION 103**

20 **APPLICABILITY AND SCOPE**

21 **103.1 Scope.** This code applies to the erection, installation, alteration, repair, relocation,
22 replacement, addition to, use or maintenance of any heating, ventilating, cooling, refrigeration
23 systems, incinerators or other miscellaneous heat-producing appliances within the City. The

1 design and testing of equipment regulated by this code are subject to the approval of the code
2 official.

3 **Exceptions:**

- 4 1. Detached one- and two-family dwellings and multiple single-family dwellings
5 (townhouses) not more than three stories above grade plane with a separate means of
6 egress and their accessory structures shall comply with the *International Residential*
7 *Code*.
- 8 2. The standards for liquefied petroleum gas installations are the 2014 edition of NFPA
9 58 (Liquefied Petroleum Gas Code) and the 2015 edition of ANSI Z223.1/NFPA 54
10 (National Fuel Gas Code), as amended.

11 **103.2 Applicability of city laws.** A mechanical permit application shall be considered under the
12 Seattle Mechanical, Fuel Gas and Energy codes in effect on a date as provided below, or on a
13 date as otherwise required by law.

- 14 1. Mechanical permit applications shall be considered under the codes in effect on the date
15 used to determine the codes applicable to the building permit application according to
16 Seattle Building Code Section 101.3 if any of Items 1.1 through 1.3 apply:
- 17 1.1 The mechanical permit application is submitted as part of a building permit
18 application;
- 19 1.2 The mechanical permit application is for work directly associated with a building
20 permit but is submitted separately from the building permit application; or
- 21 1.3 The mechanical permit application is for initial tenant alterations submitted no later
22 than 18 months after the date of the approved final inspection for the building, and is

1 submitted before the expiration date of the building permit for the tenant alteration, as
2 determined by Seattle Building Code Section 106.9.

3 2. Mechanical permit applications other than those subject to Item 1 shall be considered
4 under the codes in effect on the date a complete mechanical permit application is
5 submitted that complies with all the requirements of Section 116.

6 **103.3 Additions, alterations and repairs.** Additions, alterations, repairs and replacement of
7 equipment or systems shall comply with the provisions for new equipment and systems except as
8 otherwise provided in Section 104 of this code.

9 **Exception:** Additions, alterations, renovations or repairs to a mechanical system that is part
10 of a building addition with less than 500 square feet of conditioned floor area are exempt
11 from the requirements for whole house ventilation systems, Section 403.8.5.

12 **103.4 Internal consistency.** If in any specific case, different sections of this code specify
13 different materials, methods of construction or other requirements, the most restrictive governs.
14 If there is a conflict between a general requirement and a specific requirement, the specific
15 requirement governs.

16 **103.5 Referenced codes and standards.** The codes and standards referenced in this code are
17 part of the requirements of this code to the extent prescribed by each such reference. If
18 differences occur between provisions of this code and referenced codes and standards, the
19 provisions of this code apply.

20 **Exception:** Where enforcement of a code provision would violate the conditions of the
21 listing of the equipment or appliance, the conditions of the listing and manufacturer's
22 instructions apply.

1 **103.6 Appendices.** Provisions in the *International Mechanical Code* appendices do not apply
2 unless specifically adopted.

3 **103.7 Metric units.** Wherever in this code there is a conflict between metric units of
4 measurement and U.S. customary units, the U.S. customary units govern.

5 **103.8 References to other codes.** Whenever an International, National or Uniform Code is
6 referenced in this code, it means the Seattle edition of that code, including local amendments.
7 References to the “Building Code”, “Fuel Gas Code”, “Fire Code”, “Residential Code” and
8 “Plumbing Code” mean the Seattle editions of those codes.

9 **SECTION 104**

10 **APPLICATION TO EXISTING MECHANICAL SYSTEMS**

11 **104.1 Additions, alterations, renovations or repairs.** Additions, alterations, renovations or
12 repairs may be made to any mechanical system without requiring the existing mechanical system
13 to comply with all the requirements of this code, if the addition, alteration, renovation or repair
14 conforms to the standards required for a new mechanical system. Additions, alterations,
15 renovations or repairs shall not cause an existing system to become unsafe, unhealthy or
16 overloaded.

17 Minor additions, alterations, renovations, and repairs to existing mechanical systems may be
18 installed in accordance with the law in effect at the time the original installation was made, if
19 approved by the code official.

20 **104.2 Existing installations.** Mechanical systems lawful at the time of the adoption of this code
21 may continue their use, be maintained or repaired, be converted to another type of fuel, or have
22 components replaced if the use, maintenance, repair, conversion of fuel, or component

1 replacement is done in accordance with the basic original design and location, and no hazard to
2 life, health or property has been or is created by such mechanical system.

3 **104.3 Changes in building occupancy.** Mechanical systems that are a part of a building or
4 structure undergoing a change in occupancy as defined in the International Building Code shall
5 comply with all requirements of this code that are applicable to the new use or occupancy.

6 **104.4 Maintenance.** All mechanical systems, materials, equipment, appurtenances and all parts
7 thereof shall be maintained in proper operating condition in accordance with the original design
8 and in a safe and hazard-free condition. All devices or safeguards that were required by a code in
9 effect when the mechanical system was installed shall be maintained in conformance with the
10 code edition under which installed. The owner or the owner's authorized agent is responsible for
11 maintenance of mechanical systems and equipment. To determine compliance with this
12 subsection, the code official may cause a mechanical system or equipment to be reinspected.

13 The fire chief and the code official each have authority to obtain compliance with the
14 requirements of this subsection.

15 **Exception:** The code official may modify the requirements of this section where all or a
16 portion of the building is unoccupied.

17 **104.5 Moved buildings.** Building or structures moved into or within the City shall comply with
18 standards adopted by the code official. No building shall be moved into or within the City unless,
19 prior to moving, the code official has inspected the building for compliance with this code and
20 the permit holder has agreed to correct all deficiencies found and has been issued a building
21 permit for the work. A bond or cash deposit in an amount sufficient to abate or demolish the
22 building shall be posted prior to issuance of a permit. See Section 116 for information required
23 on plans. Any moved building that is not in complete compliance with standards for moved

1 buildings within eighteen months from the date of permit issuance and is found to be a public
2 nuisance may be abated.

3 **104.6 Landmarks--Historic buildings and structures.** The code official may modify the
4 specific requirements of this code as it applies to landmarks and require in lieu thereof alternate
5 requirements that, in the opinion of the code official, will result in a reasonable degree of safety
6 to the public and the occupants of those buildings.

7 For purposes of this section a landmark is a building or structure: that is subject to a
8 requirement to obtain a certificate of approval from the City Landmarks Preservation Board
9 before altering or making significant changes to specific features or characteristics, that has been
10 nominated for designation and the City Landmarks Preservation Board has not issued a
11 determination regarding designation, that has been designated for preservation by the City
12 Landmarks Preservation Board, that has been designated for preservation by the State of
13 Washington, that has been listed or determined eligible to be listed in the National Register of
14 Historic Places, or that is located in a landmark or special review district subject to a requirement
15 to obtain a certificate of approval before making a change to the external appearance of a
16 structure.

17 SECTION 105

18 ALTERNATE MATERIALS AND METHODS OF CONSTRUCTION

19 **105.1 Alternate materials and methods of construction and design.** This code does not
20 prevent the use of any material, design or method of construction not specifically allowed or
21 prohibited by this code, provided the alternate has been approved and its use authorized by the
22 code official. The code official may approve an alternate, provided the code official finds that the
23 proposed alternate complies with the provisions of this code and that the alternate, when

1 considered together with other safety features of the building or other relevant circumstances,
2 will provide at least an equivalent level of strength, effectiveness, fire resistance, durability,
3 safety and sanitation. The code official may require that sufficient evidence or proof be
4 submitted to reasonably substantiate any claims regarding the use or suitability of the alternate.
5 The code official may, but is not required to, record the approval of alternates and any relevant
6 information in the files of the code official or on the approved construction documents.

7 SECTION 106

8 MODIFICATIONS

9 **106.1 Modifications.** The code official may modify the provisions of this code for individual
10 cases if the code official finds: (1) there are practical difficulties involved in carrying out the
11 provisions of this code; (2) the modification is in conformity with the intent and purpose of this
12 code; and (3) the modification will provide a reasonable level of strength, effectiveness, fire
13 resistance, durability, safety and sanitation when considered together with other safety features
14 of the building or other relevant circumstances. The code official may, but is not required to,
15 record the approval of modifications and any relevant information in the files of the code official
16 or on the approved construction documents.

17 SECTION 107

18 TESTS

19 **107.1 Tests.** Whenever there is insufficient evidence of compliance with the provisions of this
20 code or evidence that any material or method of construction does not conform to the
21 requirements of this code, the code official may require tests as proof of compliance, to be made
22 at no expense to the City. Test methods shall be as specified in this code or by other recognized
23 test standards. If there are no recognized and accepted test methods for the proposed alternate,

1 the code official shall determine the test procedures. All tests shall be made by an approved
2 agency. Reports of such tests shall be retained by the code official for the period required for
3 retention of public records.

4 **SECTION 108**

5 **ORGANIZATION AND DUTIES OF CODE OFFICIAL**

6 **108.1 Jurisdiction of the Department of Construction and Inspections.** The Department of
7 Construction and Inspections is authorized to administer and enforce this code. The Department
8 of Construction and Inspections is under the administrative and operational control of the
9 Director, who is the code official.

10 **108.2 Designees.** The code official may appoint such officers, inspectors, assistants and
11 employees as are authorized from time to time. The code official may authorize such employees
12 and other agents as may be necessary to carry out the functions of the code official.

13 **108.3 Right of entry.** With the consent of the owner or occupier of a building or premises, or
14 pursuant to a lawfully issued warrant, the code official may enter a building or premises at any
15 reasonable time to perform the duties imposed by this code.

16 **108.4 Liability.** Nothing in this code is intended to be nor shall be construed to create or form
17 the basis for any liability on the part of the City, or its officers, employees or agents, for any
18 injury or damage resulting from the failure of equipment to conform to the provisions of this
19 code, or by reason or as a consequence of any inspection, notice, order, certificate, permission or
20 approval authorized or issued or done in connection with the implementation or enforcement of
21 this code, or by reason of any action or inaction on the part of the City related in any manner to
22 the enforcement of this code by its officers, employees or agents.

1 This code shall not be construed to lessen or relieve the responsibility of any person owning,
2 operating or controlling any equipment, building or structure for any damages to persons or
3 property caused by defects, nor shall the Seattle Department of Construction and Inspections or
4 the City of Seattle be held to have assumed any such liability by reason of the inspections
5 authorized by this code or any permits or certificates issued under this code.

6 **108.5 Responsibility for compliance.** Compliance with the requirements of this code is the
7 obligation of the owner of the building, structure or premises, the authorized agent of the owner,
8 and other persons responsible for the condition or work, and not of the City or any of its officers,
9 employees or agents.

10 SECTION 109

11 UNSAFE EQUIPMENT AND HAZARD CORRECTION ORDER

12 **109.1 Emergency order.** Whenever the code official finds that any equipment regulated by this
13 code is in such a dangerous and unsafe condition as to constitute an imminent hazard to life or
14 limb, the code official may issue an emergency order. The emergency order may (1) direct that
15 the equipment be restored to a safe condition by a date certain; (2) require that the building,
16 structure or premises, or portion thereof, containing the equipment be vacated within a
17 reasonable time to be specified in the order, or in the case of extreme danger, the order may
18 specify immediate vacation of the building, structure or premises, or portion thereof; or (3)
19 authorize immediate disconnection of the utilities or energy source.

20 **109.1.1 Service of emergency order.** The order shall be posted on the premises or
21 personally served on the owner of the building or premises or any person responsible for the
22 condition. The order shall specify the time for compliance.

1 **109.1.2 Effect of emergency order.** No person may occupy a building, structure or
2 premises, or portion thereof, after the date on which the building is required to be vacated
3 until the building, structure or premises, or portion thereof, is restored to a safe condition as
4 required by the order and this code. It is a violation for any person to fail to comply with an
5 emergency order issued by the code official.

6 **109.2 Hazard correction order.** Whenever the code official finds that unsafe equipment exists,
7 the code official may issue a hazard correction order specifying the conditions causing the
8 equipment to be unsafe and directing the owner or other person responsible for the unsafe
9 equipment to correct the condition by a date certain. In lieu of correction, the owner may submit
10 a report or analysis to the code official analyzing said conditions and establishing that the
11 equipment is, in fact, safe. The code official may require that the report or analysis be prepared
12 by a licensed engineer.

13 **109.2.1 Service of hazard correction order.** The order shall be served upon the owner,
14 agent or other responsible person by personal service or regular first class mail addressed to
15 the last known address of such person or if no address is available after reasonable inquiry,
16 the order may be posted in a conspicuous place on the premises. The order may also be
17 posted if served by personal service or first class mail.

18 **109.2.2 Effect of hazard correction order.** It is a violation for any person to fail to comply
19 with a hazard correction order as specified in this subsection.

1 **110.2.1 Service of notice of violation.** The notice shall be served upon the owner, agent or
2 other responsible person by personal service or regular first class mail addressed to the last
3 known address of such person, or if no address is available after reasonable inquiry, the
4 notice may be posted in a conspicuous place on the premises. The notice may also be posted
5 if served by personal service or first class mail. Nothing in this section limits or precludes
6 any action or proceeding to enforce this code, and nothing obligates or requires the code
7 official to issue a notice of violation prior to the imposition of civil or criminal penalties.

8 **110.2.2 Review of notice of violation by the code official.** Any person affected by a notice
9 of violation issued pursuant to Section 111.2 may obtain a review of the notice by making a
10 request in writing to the code official within ten days after service of the notice. When the
11 last day of the period computed is a Saturday, Sunday, or city holiday, the period runs until 5
12 p.m. of the next business day.

13 **110.2.2.1 Review procedure.** The review shall occur not less than ten nor more than 20
14 days after the request is received by the code official unless otherwise agreed to by the
15 person requesting the review. Any person affected by the notice of violation may submit
16 additional information to the code official. The review shall be made by a representative
17 of the code official who will review any additional information that is submitted and the
18 basis for issuance of the notice of violation. The reviewer may request clarification of the
19 information received and a site visit.

20 **110.2.2.2 Decision.** After the review, the code official shall:

- 21 1. Sustain the notice;
- 22 2. Withdraw the notice;
- 23 3. Amend the notice; or

1 4. Continue the review to a date certain.

2 **111.2.2.3 Order.** The code official shall issue an order containing the decision within 15
3 days of the date that the review is completed and shall cause the order to be mailed by
4 regular first class mail to the persons requesting the review and the persons named on the
5 notice of violation, addressed to their last known address.

6 **110.3 Stop work orders.** The code official may issue a stop work order whenever any work is
7 being done contrary to the provisions of this code, or contrary to a permit issued by the code
8 official, or in the event of dangerous or unsafe conditions related to equipment or construction.
9 The stop work order shall identify the violation and may prohibit work or other activity on the
10 site.

11 **110.3.1 Service of stop work order.** The code official shall serve the stop work order by
12 posting it in a conspicuous place at the site. If posting is not physically possible, the stop
13 work order may be served by personal service or by regular first class mail to the last known
14 address of: the property owner, the person doing or causing the work to be done, or the
15 holder of a permit if work is being stopped on a permit. For purposes of this section, service
16 is complete at the time of posting or of personal service, or if mailed, three days after the date
17 of mailing. When the last day of the period so computed is a Saturday, Sunday or city
18 holiday, the period runs until 5 p.m. on the next business day.

19 **110.3.2 Effective date of stop work order.** Stop work orders are effective when posted, or if
20 posting is not physically possible, when one of the persons identified in Section 111.3.1 is
21 served.

1 **110.3.3 Review of stop work orders by the code official.** Any person aggrieved by a stop
2 work order may obtain a review of the order by delivering to the code official a request in
3 writing within two business days of the date of service of the stop work order.

4 **110.3.3.1 Review procedure.** The review shall occur within two business days after
5 receipt by the code official of the request for review unless otherwise agreed by the
6 person making the request. Any person affected by the stop work order may submit
7 additional information to the code official for consideration as part of the review at any
8 time prior to the review. The review will be made by a representative of the code official
9 who will review all additional information received and may also request a site visit.

10 **110.3.3.2 Decision.** After the review, the code official may:

- 11 1. Sustain the stop work order;
- 12 2. Withdraw the stop work order;
- 13 3. Modify the stop work order; or
- 14 4. Continue the review to a date certain.

15 **110.3.3.3 Order.** The code official shall issue an order containing the decision within
16 two business days after the review is completed and shall cause the order to be sent by
17 regular first class mail to the person or persons requesting the review, any person on
18 whom the stop work order was served, and any other person who requested a copy before
19 issuance of the order, addressed to their last known address.

20 **110.4 Authority to disconnect utilities in emergencies.** The code official has the authority to
21 disconnect fuel-gas utility service or energy supplies to a building, structure, premises or
22 equipment regulated by this code in case of emergency where necessary to eliminate an
23 immediate hazard to life or property. The code official may enter any building or premises to

1 disconnect utility service. The code official shall, whenever possible, notify the serving utility,
2 the owner and the occupant of the building, structure or premises of the decision to disconnect
3 prior to taking such action, and shall notify the serving utility, owner and occupant of the
4 building, structure or premises in writing of such disconnection immediately thereafter.

5 **110.5 Authority to condemn equipment.** Whenever the code official determines that any
6 equipment or portion thereof regulated by this code is hazardous to life, health or property, the
7 code official shall order in writing that such equipment either be disconnected, removed or
8 restored to a safe or sanitary condition, as appropriate. The written notice shall fix a date certain
9 for compliance with such order. It is a violation for any person to use or maintain defective
10 equipment after receiving such notice.

11 When any equipment or installation is to be disconnected, the code official shall give written
12 notice of such disconnection and causes therefore within 24 hours to the serving utility, the
13 owner and the occupant of the building, structure or premises. When any equipment is
14 maintained in violation of this code, and in violation of a notice issued pursuant to the provisions
15 of this section, the code official shall institute any appropriate action to prevent, restrain, correct
16 or abate the violation.

17 **110.6 Connection after order to disconnect.** No person shall make connections from any
18 energy, fuel or power supply nor supply energy or fuel to any equipment regulated by this code
19 that has been disconnected or ordered to be disconnected by the code official, or the use of which
20 has been ordered to be discontinued by the code official until the code official authorizes the
21 reconnection and use of such equipment.

22 **110.7 Civil penalties.** Any person violating or failing to comply with the provisions of this code
23 is subject to a cumulative civil penalty in an amount not to exceed \$500 per day for each

1 violation from the date the violation occurs or begins until the date compliance is achieved. In
2 cases where the code official has issued a notice of violation, the violation will be deemed to
3 begin, for purposes of determining the number of days of violation, on the date compliance is
4 required by the notice of violation.

5 **110.8 Enforcement in Municipal Court.** Civil actions to enforce this code shall be brought
6 exclusively in Seattle Municipal Court, except as otherwise required by law or court rule. In any
7 civil action for a penalty, the City has the burden of proving by a preponderance of the evidence
8 that a violation exists or existed; the issuance of a notice of violation or of an order following a
9 review by the code official is not itself evidence that a violation exists.

10 **110.9 Judicial review.** Because civil actions to enforce this code must be brought exclusively in
11 Seattle Municipal Court pursuant to Section 111.8, orders of the code official, including notices
12 of violation issued under this chapter, are not subject to judicial review pursuant to chapter
13 36.70C RCW.

14 **110.10 Alternative criminal penalty.** Anyone who violates or fails to comply with any notice of
15 violation or order issued by the code official pursuant to this code or who removes, mutilates,
16 destroys or conceals a notice issued or posted by the code official shall, upon conviction thereof,
17 be punished by a fine of not more than \$5000 or by imprisonment for not more than 365 days, or
18 by both such fine and imprisonment for each separate violation. Each day's violation shall
19 constitute a separate offense.

20 **110.11 Additional relief.** The code official may seek legal or equitable relief to enjoin any acts
21 or practices and abate any condition when necessary to achieve compliance.

22 **110.12 Administrative review by the code official.** Prior to issuance of the mechanical permit,
23 applicants may request administrative review by the code official of decisions or actions

1 pertaining to the administration and enforcement of this code. Requests shall be addressed to the
2 code official.

3 **110.13 Administrative review by the Construction Codes Advisory Board.** After
4 administrative review by the code official, and prior to issuance of the mechanical permit,
5 applicants may request review of decisions or actions pertaining to the application and
6 interpretation of this code by the Construction Codes Advisory Board according to International
7 Building Code Section 103.11, except for stop work orders, notices of violations and revocations
8 of permits. The review will be performed by three or more members of the Construction Codes
9 Advisory Board, chosen by the Board Chair. The Chair shall consider the subject of the review
10 and members' expertise when selecting members to conduct a review. The decision of the review
11 panel is advisory only; the final decision is made by the code official.

12 **110.14 Recording.** The code official may record a copy of any order or notice with the
13 Department of Records and Elections of King County.

14 **110.15 Appeal to Superior Court.** Final decisions of the Seattle Municipal Court on
15 enforcement actions authorized by Title 22 and this code may be appealed pursuant to the Rules
16 for Appeal of Decisions of Courts of Limited Jurisdiction.

17 SECTION 111

18 RULES OF THE CODE OFFICIAL

19 **111.1 Authority.** The code official has authority to issue interpretations of this code and to adopt
20 and enforce rules and regulations supplemental to this code as may be deemed necessary to
21 clarify the application of the provisions of this code. Such interpretations, rules and regulations
22 shall be in conformity with the intent and purpose of this code.

1 **111.2 Procedure for adoption of rules.** The code official shall promulgate, adopt and issue
2 rules according to the procedures specified in the Administrative Code, Chapter 3.02 of the
3 Seattle Municipal Code.

4 SECTION 112

5 CONSTRUCTION CODES ADVISORY BOARD

6 **112.1 Construction Codes Advisory Board committee.** A committee of the Construction
7 Codes Advisory Board may examine proposed administrative rules, and amendments relating to
8 this code and related provisions of other codes and make recommendations to the code official
9 and to the City Council for changes in this code. The committee will be called on as needed by
10 the Construction Codes Advisory Board.

11 SECTION 113

12 PERMITS

13 **113.1 Permits required.** Except as otherwise specifically provided in this code, a permit shall be
14 obtained from the code official prior to each installation, alteration, repair, replacement or
15 remodel of any equipment or mechanical system regulated by this code. A separate mechanical
16 permit is required for each separate building or structure.

17 **113.2 Work exempt from permit.**

18 **113.2.1 Mechanical.** A mechanical permit is not required for the work listed below.

- 19 1. Portable heating appliances, portable ventilating equipment, and portable cooling
20 units, if the total capacity of these portable appliances does not exceed 40 percent of
21 the cumulative heating, cooling or ventilating requirements of a building or dwelling
22 unit and does not exceed 3 kW or 10,000 Btu input.

- 1 2. Any closed system of steam, hot or chilled water piping within heating or cooling
2 equipment regulated by this code.
- 3 3. Minor work or the replacement of any component part of a mechanical system that
4 does not alter its original approval and complies with other applicable requirements of
5 this code.

6 **113.2.2 Refrigeration.** A mechanical permit is not required for the following refrigerant
7 equipment:

- 8 1. Any self-contained refrigerating equipment for which an operating permit is not
9 required.
- 10 2. Any self-contained refrigeration system that does not exceed three horsepower rating.

11 **113.3 Compliance required.** All work shall comply with this code, even where no permit is
12 required.

13 **113.4 Flood hazard areas.** In addition to the permit required by this section, all work to be
14 performed in areas of special flood hazard as defined in Chapter 25.06 of the Seattle Municipal
15 Code, subject to additional standards and requirements set forth in Chapter 25.06, the Seattle
16 Floodplain Development Ordinance.

17 **113.5 Emergency repairs.** In the case of an emergency, the installation, alteration or repair of
18 any refrigeration system or equipment may be made without a permit, provided that application
19 for a permit is made within the later of 24 hours or one working day from the time when the
20 emergency work was started.

1 9. Substantially conform with applicable law in effect on the date described in Section
2 R101.3, as modified by any exception.

3 **114.2 Construction documents.** Construction documents shall be submitted in one or more sets
4 with each application for a permit, or shall be submitted in electronic format determined by the
5 code official. The code official may require plans, computations and specifications to be
6 prepared and designed by an engineer or architect licensed by the state to practice as such.
7 Projects having a total mechanical valuation of \$50,000 or larger shall have a mechanical
8 engineering stamp and signature on each sheet.

9 **Exception:** A mechanical engineer's stamp or submission of construction documents is not
10 required if the code official finds that the nature of the work applied for is such that review of
11 construction documents is not necessary to obtain compliance with this code.

12 **114.3 Information on construction documents.**

13 **114.3.1 Clarity of plans.** Plans shall be drawn to a clearly indicated and commonly accepted
14 scale in a format determined by the code official.

15 **114.3.2 Fire-resistive notes.** The code official may require that plans for buildings more than
16 two stories in height of other than Group R-3 and Group U occupancies indicate how
17 required structural and fire-resistive integrity will be maintained where a penetration will be
18 made for electrical, mechanical, plumbing and communication conduits, pipes and similar
19 systems.

20 **114.3.3 Information required on plans.** The plans or specifications shall show the
21 following:

- 22 1. Layout for each floor with dimensions of all working spaces and a legend of all
23 symbols used.

- 1 1. The work described in the construction documents substantially conforms to the
- 2 requirements of this code and other pertinent laws and ordinances;
- 3 2. The fees specified in the Seattle Municipal Code, Title 22, Subtitle IX, Permit Fees have
- 4 been paid; and
- 5 3. The applicant has complied with all requirements to be performed prior to issuance of a
- 6 permit for the work under other pertinent laws, ordinances or regulations or included in a
- 7 master use permit, or otherwise imposed by the building official.

8 When the permit is issued, the applicant or the applicant’s authorized agent becomes the

9 permit holder.

10 **115.1.2 Compliance with approved construction documents.** When the code official

11 issues a permit, the code official shall endorse the permit in writing or in electronic format

12 and stamp the plans “APPROVED.” Such approved plans and permit shall not be changed,

13 modified or altered without authorization from the code official, and all work shall be done in

14 accordance with the approved construction documents and permit except as authorized by the

15 code official during a field inspection to correct errors or omissions, or as authorized by

16 Section 115.2.

17 **115.2 Revisions to the permit.** When changes to the approved work are made during

18 construction, approval of the code official shall be obtained prior to execution. The building or

19 mechanical inspector may approve minor changes for work not reducing the structural strength

20 or fire and life safety of the structure. The building or mechanical inspector shall determine if it

21 is necessary to revise the approved construction documents. If revised plans are required,

22 changes shall be submitted to and approved by the code official, accompanied by fees specified

23 in the Seattle Municipal Code, Title 22, Subtitle IX, Permit Fees prior to occupancy. All changes

1 shall conform to the requirements of this code and other pertinent laws and ordinances and other
2 issued permits.

3 Minor changes shall not incur additional fees if these changes do not (1) add to the general
4 scope of work; (2) change the basic design concept; (3) involve major relocation of equipment,
5 ducts, or pipes; (4) substantially alter approved equipment size; or (5) require extensive re-
6 view of the plans and specifications.

7 **115.3 Cancellation of permit applications.** Applications may be cancelled if no permit is issued
8 by the earlier of the following: (1) twelve months following the date of application; or (2) sixty
9 days after the date of written notice that the permit is ready to be issued. After cancellation,
10 construction documents may be returned to the applicant or destroyed by the code official.

11 The code official shall notify the applicant in writing at least 30 days before the application is
12 cancelled. The notice shall specify a date by which a request for extension must be submitted in
13 order to avoid cancellation. The date shall be at least two weeks prior to the date on which the
14 application will be cancelled.

15 **115.4 Extensions prior to permit issuance.** At the discretion of the code official, applications
16 for projects that require more than 12 months to review and approve may be extended for a
17 period that provides reasonable time to complete the review and approval, but in no case longer
18 than 24 months from the date of the original application. No application may be extended more
19 than once. After cancellation, the applicant shall submit a new application and pay a new fee to
20 restart the permit process.

21 Notwithstanding other provisions of this code, applications may be extended where issuance
22 of the permit is delayed by litigation, preparation of environmental impact statements, appeals,

1 strikes or other causes related to the application that are beyond the applicant's control, or while
2 the applicant is making progress toward issuance of a master use permit.

3 **115.5 Retention of plans.** One set of approved plans, which may be on microfilm or in
4 electronic format, shall be retained by the code official. One set of approved plans shall be
5 returned to the applicant and shall be kept at the site of the building or work for use by the
6 inspection personnel at all times when the work authorized is in progress.

7 **115.6 Validity of permit.** The issuance or granting of a permit or approval of construction
8 documents shall:

- 9 1. Not be construed to be a permit for, or an approval of, any violation of any of the
10 provisions of this code or other pertinent laws and ordinances.
- 11 2. Not prevent the code official from requiring the correction of errors in the construction
12 documents, or from preventing building operations being carried on thereunder when in
13 violation of this code or of other pertinent laws and ordinances of the City.
- 14 3. Not prevent the code official from requiring correction of conditions found to be in
15 violation of this code or other pertinent laws and ordinances of the City, or
- 16 4. Not be construed to extend the period of time for which any such permit is issued or
17 otherwise affect any period of time for compliance specified in any notice or order issued
18 by the code official or other administrative authority requiring the correction of any such
19 conditions.

20 **115.7 Expiration of permits.** Authority to do the work authorized by a permit expires 18
21 months from the date of issuance. An approved renewal extends the life of a permit for an

1 additional 18 months from the prior expiration date. An approved reestablishment extends the
2 life of the permit for 18 months from the date the permit expired.

3 **Exceptions:**

- 4 1. Initial permits for major construction projects that require more than 18 months to
5 complete may be issued for a period that provides reasonable time to complete the
6 work, according to an approved construction schedule. The building official may
7 authorize a permit expiration date not to exceed three years from the date of issuance.
8 2. The code official may issue permits that expire in less than 18 months if the code
9 official determines a shorter period is appropriate to complete the work.

10 **115.8 Renewal of permits.** Permits may be renewed and renewed permits may be further
11 renewed by the code official, if the following conditions are met:

- 12 1. Application for renewal is made within the 30 day period immediately preceding the date
13 of expiration of the permit; and
14 2. If the project has had an associated discretionary Land Use review, and the land use
15 approval has not expired; and
16 3. If an application for renewal is made more than 18 months after the date of mandatory
17 compliance with a new or revised edition of this code, the permit shall not be renewed
18 unless:
19 3.1 The code official determines that the permit complies, or is modified to comply
20 with the Seattle Mechanical, Fuel Gas and Energy codes in effect on the date of
21 application for renewal; or
22 3.2 The work authorized by the permit is substantially underway and progressing at a
23 rate approved by the building official. “Substantially underway” means that

1 normally required inspections have been approved for work such as foundations,
2 framing, mechanical, insulation and finish work is being completed on a continuing
3 basis; or

- 4 3.3 Commencement or completion of the work authorized by the permit is delayed by
5 litigation, appeals, strikes or other extraordinary circumstances related to the work
6 authorized by the permit, beyond the permit holder's control, subject to approval by
7 the code official.

8 **115.9 Reestablishment of expired permits.** A new permit is required to complete work if a
9 permit has expired and was not renewed.

10 **Exception:** A permit that expired less than one year prior to the date of a request for
11 reestablishment may be reestablished upon approval of the code official if it complies with
12 Items 2 and 3 of Section 117.8. Once re-established the permit will not be considered to have
13 expired. The new expiration date of a re-established permit shall be determined in accordance
14 with Section 117.7.

15 **115.10 Revocation of mechanical permits.** Whenever the code official determines there are
16 grounds for revoking a permit, the code official may issue a notice of revocation. The notice of
17 revocation shall identify the reason for the proposed revocation, including, but not limited to, the
18 violations, the conditions violated, and any alleged false or misleading information provided.

19 **115.10.1 Standards for revocation.** The code official may revoke a permit if:

- 20 1. The code or the permit has been or is being violated and issuance of a notice of
21 violation or stop work order has been or would be ineffective to secure compliance
22 because of circumstances related to the violation; or
23 2. The permit was obtained with false or misleading information.

1 **115.10.2 Service of notice of revocation.** The notice of revocation shall be served upon the
2 owner, agent or other responsible person by personal service or regular first class mail
3 addressed to the last known address of such person or if no address is available after
4 reasonable inquiry, the notice may be posted in a conspicuous place on the premises. The
5 notice may also be posted if served by personal service or first class mail.

6 **115.10.3 Effective date of revocation.** The code official shall identify in the notice of
7 revocation a date certain on which the revocation will take effect. This date may be stayed
8 pending complete review by the code official pursuant to Section 117.10.4.

9 **115.10.4 Review by the code official for notice of revocation.** Any person aggrieved by a
10 notice of revocation may obtain a review by making a request in writing to the code official
11 within three business days of the date of service of the notice of revocation. The review shall
12 occur within five business days after receipt by the building official of the request for review.
13 Any person affected by the notice of revocation may submit additional information to the
14 building official for consideration as part of the review at any time prior to the review.

15 **115.10.4.1 Review procedure.** The review will be made by a representative of the code
16 official who will review all additional information received and may also request a site
17 visit. After the review, the code official may:

- 18 1. Sustain the notice of revocation and affirm or modify the date the revocation will
19 take effect;
- 20 2. Withdraw the notice of revocation;
- 21 3. Modify the notice of revocation and affirm or modify the date the revocation will
22 take effect; or
- 23 4. Continue the review to a date certain.

1 code official. Neither the code official nor the City shall be liable for expense entailed in the
2 required removal or replacement of any material to allow inspection.

3 **116.4 Inspection record.** Work requiring a mechanical permit shall not be commenced until the
4 permit holder or the permit holder's agent has posted an inspection record in a conspicuous place
5 on the premises and in a position that allows the code official to conveniently make the required
6 entries regarding inspection of the work. This record shall be maintained in such a position by
7 the permit holder or the permit holder's agent until final approval has been granted by the code
8 official.

9 **116.5 Approvals required.** No work shall be done on any part of the building or structure
10 beyond the point indicated in each successive inspection without first obtaining the written
11 approval of the code official.

12 **116.5.1 Effect of approval.** Approval as a result of an inspection is not approval of any
13 violation of the provisions of this code or of other pertinent laws and ordinances of the City.
14 Inspections presuming to give authority to violate or cancel the provisions of this code or of
15 other pertinent laws and ordinances of the City are not valid.

16 **116.6 Final inspection.** When the installation of a mechanical system is complete, an additional
17 and final inspection shall be made.

18 **116.7 Operation of mechanical equipment.** The requirements of this section do not prohibit the
19 operation of any mechanical systems installed to replace existing equipment or fixtures serving
20 an occupied portion of the building in the event a request for inspection of such equipment or
21 fixture has been filed with the code official not more than 48 hours after such replacement work
22 is completed, and before any portion of such mechanical system is concealed by any permanent
23 portion of the building.

1 **116.8 Testing of equipment and systems.** Refrigeration equipment regulated by this code shall
2 be tested and approved as required by Chapter 11 of this code. Fuel-oil piping shall be tested and
3 approved as required by Chapter 13 of this code.

4 **116.9 Special investigation.** If work that requires a permit or approval is commenced or
5 performed prior to making formal application and receiving the code official's permission to
6 proceed, the code official may make a special investigation inspection before a permit is issued
7 for the work. If a special investigation is made, a special investigation fee may be assessed in
8 accordance with the Fee Subtitle.

9 **116.10 Reinspections.** The code official may require a reinspection if work for which inspection
10 is called is not complete, required corrections are not made, the inspection record is not properly
11 posted on the work site, the approved plans are not readily available to the inspector, access is
12 not provided on the date for which inspection is requested, if deviations from construction
13 documents that require the approval of the code official have been made without proper
14 approval, or as otherwise required by the code official.

15 **116.10.1 Compliance with Section 104.4.** For the purpose of determining compliance with
16 Section 104.4, Maintenance, the code official or the fire chief may cause any structure or
17 system to be reinspected.

18 **116.10.2 Reinspection fee.** The code official may assess a reinspection fee as set forth in the
19 Seattle Municipal Code, Title 22, Subtitle IX, Permit Fees for any action for which
20 reinspection is required. In instances where reinspection fees have been assessed, no
21 additional inspection of the work will be performed until the required fees have been paid.

1 **201.3 Terms defined in other codes.** Where terms are not defined in this code and are defined
2 in the *International Building Code*, *International Fire Code*, *Seattle Electrical Code*,
3 *International Fuel Gas Code* or the (~~*International*~~) *Uniform Plumbing Code*, such terms shall
4 have meanings ascribed to them as in those codes.

5 * * *

6 SECTION 202

7 GENERAL DEFINITIONS

8 * * *

9 (~~**AUTOMATIC BOILER.** Any class of boiler that is equipped with the controls and limit
10 devices specified in Chapter 10.~~)

11 * * *

12 **BOILER.** A closed (~~(heating appliance intended to supply hot water or steam for space heating,
13 processing or power purposes. Low pressure boilers operate at pressures less than or equal to 15
14 pounds per square inch (psi) (103 kPa) for steam and 160 psi (1103 kPa) for water. High-
15 pressure boilers operate at pressures exceeding those pressures)~~) vessel in which water is heated,
16 steam is generated, steam is superheated, or any combination thereof, under pressure or vacuum
17 by the direct application of heat. The term boiler shall also include fired units for heating or
18 vaporizing liquids other than water where these systems are complete within themselves.

19 **BOILER CODE.** The *Seattle Boiler and Pressure Vessel Code*

20 * * *

21 **[A] CODE.** These regulations, subsequent amendments thereto, or any emergency rule or
22 regulation that (~~(the administrative authority having jurisdiction)~~) has been lawfully adopted.

1 **[A] CODE OFFICIAL.** ~~The ((officer or other designated authority charged with the~~
2 ~~administration and enforcement of this code))~~ Director of the Department of Construction and
3 Inspections, or a duly authorized representative.

4 * * *

5 **CONDITIONED SPACE.** ~~An area, or room or space that is enclosed within the a building~~
6 ~~thermal envelope and that is directly heated or cooled or that is indirectly being heated or cooled,~~
7 containing uninsulated ducts, or with a fixed opening directly into an adjacent conditioned space.

8 ~~((Spaces are indirectly heated or cooled where they communicate through openings with~~
9 ~~conditioned spaces, where they are separated from conditioned spaces by uninsulated walls,~~
10 ~~floors or ceilings, or where they contain uninsulated ducts, piping or other sources of heating or~~
11 ~~cooling.))~~ Elevator shafts, stair enclosures, enclosed corridors connecting conditioned spaces,
12 and enclosed spaces, through which conditioned air is transferred at a rate exceeding three air
13 changes per hour are considered conditioned spaces for the purpose of the building thermal
14 envelope requirements.

15 **CONFINED SPACE.** A space having a volume less than 50 cubic feet per 1,000 Btu per hour
16 (Btu/h) (4.8 m³/kW) of the aggregate input rating of all appliances installed in that space.

17 * * *

18 **CONTAINER (REFRIGERANT).** A cylinder for the transportation of refrigerant.

19 * * *

20 **DIRECT REFRIGERATION SYSTEM.** A system in which the evaporator or condenser of the
21 refrigerating system is in direct contact with the air or other substances to be cooled or heated.

22 See figure 2-1 for a diagram of a type of direct refrigeration system.

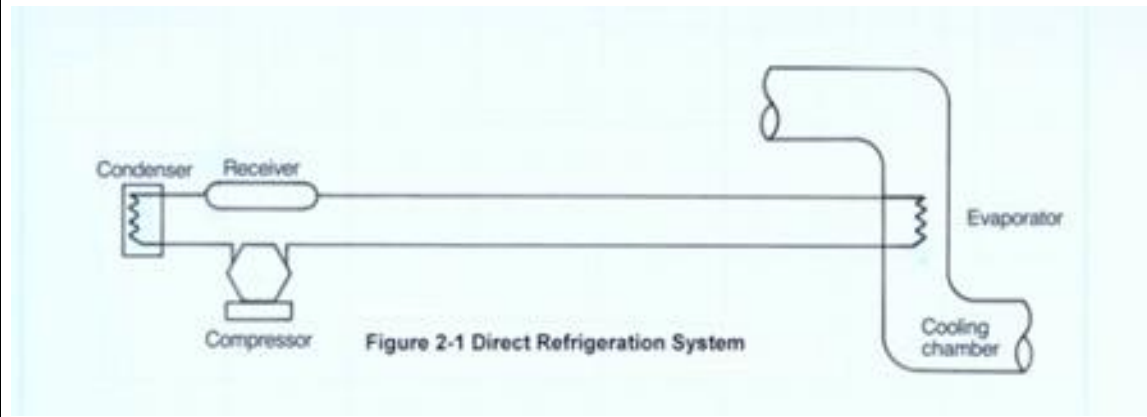

1
2
3
4
5
6
7
8
9
10
11
12
13
14
15
16
17

* * *

ENVIRONMENTAL AIR. Air that is, at temperatures not exceeding 250°F (121°C), conveyed to or from occupied areas through ducts which are not part of the heating or air-conditioning system, such as ventilation for human usage, relief air, domestic kitchen range exhaust, bathroom exhaust, domestic clothes dryer exhaust, transformer vault exhaust, elevator exhaust, and parking garage exhaust.

* * *

EXIT PASSAGEWAY. An exit component that provides a protected path of egress travel in a horizontal direction to an exit or to the exit discharge.

Exit Passageway is a definition pulled directly from the 2015 Seattle Building Code

* * *

FIRE AREA. The aggregate floor area enclosed and bounded by fire walls, fire barriers, exterior walls or horizontal assemblies of a building. Areas of the building not provided with surrounding walls shall be included in the fire area if such areas are included within the horizontal projection of the roof or floor next above.

* * *

1 **[F] GAS ROOM.** A separately ventilated, fully enclosed room in which only compressed gases
2 and associated equipment and supplies are stored or used.

3 * * *

4 **[B] HIGH-RISE BUILDING.** A building with an occupied floor located more than 75 feet (22
5 860 mm) above the lowest level of fire department vehicle access.

6 * * *

7 **HOOD.** An air intake device used to capture by entrapment, impingement, adhesion or similar
8 means, grease, moisture, heat and similar contaminants before they enter a duct system.

9 **Type I.** A kitchen hood for collecting and removing grease vapors and smoke generated from
10 medium-duty, heavy-duty, extra-heavy-duty, and some light-duty cooking appliances. Such
11 hoods are equipped with a fire suppression system.

12 **Type II.** A general kitchen hood for collecting and removing steam, vapor, heat, odors and
13 products of *combustion* generated from some light-duty cooking appliances.

14 * * *

15 **INDIRECT REFRIGERATION SYSTEM.** A system in which a secondary coolant cooled or
16 heated by the refrigerating system is circulated to the air or other substance to be cooled or
17 heated. See Figure 2-2. Indirect systems are distinguished by the following methods of
18 application:

19 **Closed system.** A system in which a secondary fluid is either cooled or heated by the
20 refrigerating system and then circulated within a closed circuit in indirect contact with the air
21 or other substance to be cooled or heated.

1 **Double-indirect open-spray system.** A system in which the secondary substance for an
2 indirect open-spray system is heated or cooled by an intermediate coolant circulated from a
3 second enclosure.

4 **Open-spray system.** A system in which a secondary coolant is cooled or heated by the
5 refrigerating system and then circulated in direct contact with the air or other substance to be
6 cooled or heated.

7 **Vented closed system.** A system in which a secondary coolant is cooled or heated by the
8 refrigerating system and then passed through a closed circuit in the air or other substance to
9 be cooled or heated, except that the evaporator or condenser is placed in an open or
10 appropriately vented tank.

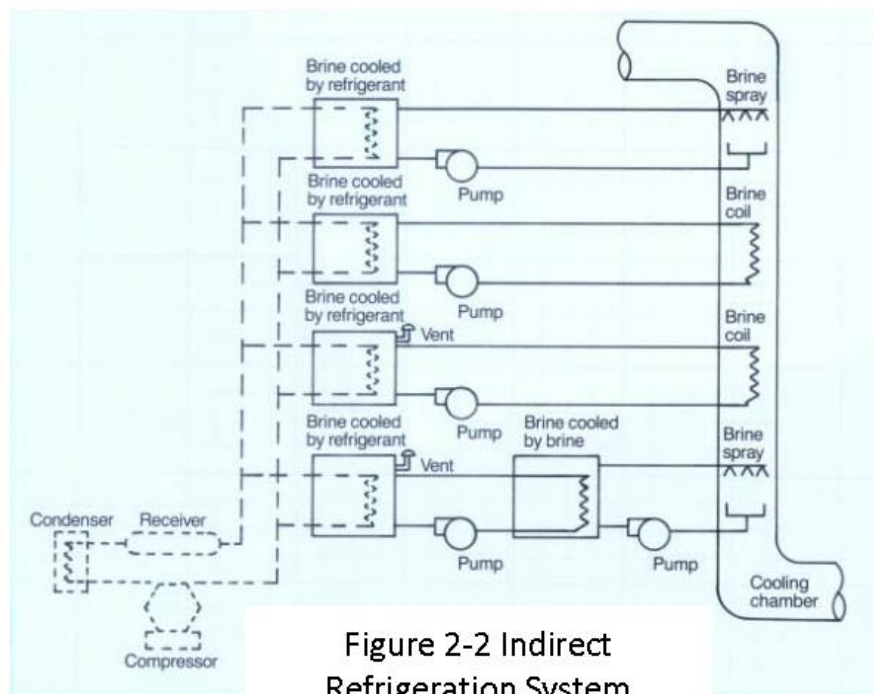

11

12

* * *

1 **INTERIOR EXIT STAIRWAY.** An exit component that serves to meet one or more means of
2 egress design requirements, such as required number of exits or exit access travel distance, and
3 provides for a protected path of egress travel to the exit discharge or public way.

4 *Interior Exit Stairway* is a definition pulled directly from the 2015 Seattle Building Code.

5 * * *

6 **LIGHT-DUTY COOKING APPLIANCE.** Light-duty cooking appliances include gas and
7 electric ovens of a maximum 6 kW or 20,000 Btu/h capacity (including standard, bake, roasting,
8 revolving, retherm, convection, combination convection/steamer, countertop conveyerized
9 baking/finishing, deck and pastry), electric and gas steamjacketed kettles, electric and gas pasta
10 cookers, electric and gas compartment steamers (both pressure and atmospheric) and electric and
11 gas cheesemelters.

12 * * *

13 **[W] LOCAL EXHAUST.** An exhaust system that uses one or more fans to exhaust air from a
14 specific room or rooms within a dwelling.

15 * * *

16 **MEDIUM-DUTY COOKING APPLIANCE.** Medium-duty cooking *appliances* include
17 electric discrete element ranges (with or without oven), electric and gas hot-top ranges, electric
18 and gas griddles, electric and gas doublesided griddles, electric and gas fryers (including open
19 deep fat fryers, donut fryers, kettle fryers and pressure fryers), (~~electric and gas conveyor pizza~~
20 ~~ovens~~), electric and gas tilting skillets (braising pans) and electric and gas rotisseries.

21 * * *

22 **[W] PERMANENT CONSTRUCTION.** Construction that if removed would disturb the
23 structural integrity of the building or the fire resistance rating of a building assembly.

1 **PERSON.** Any individual, receiver, administrator, executor, assignee, trustee in bankruptcy,
2 trust, estate, firm, partnership, joint venture, club, company, joint stock company, business trust,
3 municipal corporation, political subdivision of the State of Washington, corporation, limited
4 liability company, association, society or any group of individuals acting as a unit, whether
5 mutual, cooperative, fraternal, nonprofit or otherwise, and the United States or any
6 instrumentality thereof.

7 * * *

8 ~~((**POWER BOILER.** See “Boiler.”))~~

9 * * *

10 ~~((**PRESSURE VESSELS.** Closed containers, tanks or vessels that are designed to contain~~
11 ~~liquids or gases, or both, under pressure.))~~

12 * * *

13 **PRODUCT-CONVEYING.** Conveying solid particulates, such as refuse, dust, fumes and
14 smoke; liquid particulate matter, such as spray residue, mists and fogs; vapors, such as vapors
15 from flammable or corrosive liquids; noxious and toxic gases; and air at temperatures exceeding
16 250°F (121°C). Examples include, but are not limited to, combustion engine, industrial vacuum
17 system, chemical booth, paint booth, paint enclosure and photo lab exhaust.

18 * * *

19 **RELIEF AIR.** Exhausted return air from a system that provides ventilation for human usage.

20 * * *

21 ~~((**STEAM HEATING BOILER.** A boiler operated at pressures not exceeding 15 psi (103 kPa)~~
22 ~~for steam.))~~

23 * * *

1 **THIMBLE.** A listed fitting designed to be installed in the opening in a masonry chimney
2 through which the chimney connector passes.

3 * * *

4 **UNCONFINED SPACE.** A space having a volume not less than 50 cubic feet per 1,000 Btu/h
5 (4.8m³/kW) of the aggregate input rating of all fuel-burning appliances installed in that space.
6 Rooms communicating directly with the space in which the appliances are installed, through
7 openings not furnished with doors, are considered a part of the unconfined space.

8 * * *

9 **UNSAFE.** Constituting a fire or health hazard or otherwise dangerous to human life, constituting
10 a hazard to safety, health or public welfare.

11 * * *

12 **WATER HEATER.** Any heating *appliance* or *equipment* that heats potable water and supplies
13 such water to the potable hot water distribution system, and includes only those appliances that
14 do not exceed pressure of 160 pounds per square inch (1103 kPa), volume of 120 gallons (454 L)
15 and a heat input of 200,000 Btu/hr (58.6 kW). Appliances and equipment that exceed these
16 values are classified as boilers.

17 **[W] WHOLE HOUSE VENTILATION SYSTEM.** A mechanical ventilation system,
18 including fans, controls, and ducts, which replaces, by direct or indirect means, air from the
19 habitable rooms with *outdoor* air.

20 * * *

21 Section 5. The following sections of Chapter 3 of the International Mechanical Code,
22 2015 Edition, are amended as follows:

1 **303.7 Pit locations.** Appliances installed in pits or excavations shall not come in direct contact
2 with the surrounding soil. The sides of the pit or excavation shall be held back not less than 12
3 inches (305 mm) from the *appliance*, and a minimum of 30 inches (762 mm) on the control side.

4 Where the depth exceeds 12 inches (305 mm) below adjoining grade, the walls of the pit or
5 excavation shall be lined with concrete or masonry. Such concrete or masonry shall extend not
6 less than 4 inches (102 mm) above adjoining grade and shall have sufficient lateral load-bearing
7 capacity to resist collapse. The *appliance* shall be protected from flooding in an *approved*
8 manner.

9 ~~[BF] 303.8 ((Elevator shafts. Mechanical systems shall not be located in an elevator shaft.))~~

10 **Installation of pipes or ducts conveying gases, vapors or liquids in hoistways, machine**
11 **rooms, or machinery spaces for elevators.** Pipes and ducts conveying gases, vapors or liquids
12 shall not be installed in elevator hoistways, elevator machine rooms, and elevator machinery
13 spaces.

14 **Exceptions:**

15 1. Only ducts for heating, cooling, ventilating, and venting these spaces are permitted to
16 be installed in the hoistway, machine room, and machinery space.

17 2. Ducts and electrical conduit may pass through an elevator machine room or machinery
18 space if they are separated from the room or space by construction equal to the rated
19 construction of the room or space and located so that all required clearances are
20 maintained.

21 If a vented machine room is not vented directly to the outside of the building, the vent
22 shall be enclosed within a fire barrier with at least a one-hour fire-resistance rating, or
23 as required for a shaft where it passes through occupied floors.

1 3. Standard sprinkler protection conforming to the requirements of NFPA 13 is permitted
2 to be installed in these spaces, subject to rules promulgated by the code official.

3 4. Subject to the approval of the code official, pipes that are protected with double
4 containment whose joints are threaded, soldered or welded joints are permitted. Pipes
5 shall not be located less than 7 feet above the floor in machine rooms.

6 **[B] 303.9 Interior exit stairways and exit passageways.** Mechanical systems shall not be
7 located in interior exit stairways and ramps and exit passageways. Penetrations into and openings
8 through interior exit stairways and ramps and exit passageways are prohibited except for:

9 1. Equipment allowed or required by the International Building Code to serve the interior exit
10 stairway and exit passageways such as:

11 1.1 Ductwork and equipment necessary for independent ventilation or stairway
12 pressurization,

13 1.2 Sprinkler piping,

14 1.3 Standpipes,

15 1.4 Electrical raceway serving the interior exit stairway or ramp terminating in a steel box
16 not exceeding 16 square inches (10 323 mm²) in area, and

17 1.5 Piping used exclusively for the drainage of rainfall runoff from roof areas provided
18 the roof is not used for a helistop or heliport.

19 2. Unfired heaters allowed by the *International Building Code* for freeze protection of fire
20 protection equipment may penetrate one protective membrane. The conduit serving the
21 heater may penetrate both protective membranes. Such penetrations shall be protected in
22 accordance with *International Building Code* Section 714. There shall be no penetrations

1 comply with this code and other codes as determined by the Director of Transportation and the
2 code official.

3 **Note:** The Seattle Department of Transportation (SDOT) publishes the “Seattle Right-of-Way
4 Improvements Manual” that contains detailed information on clearances and encroachments
5 (Section 4.21 Design Criteria), and required SDOT street use permits (Chapter 2). SDOT
6 discourages encroachments into the public right-of-way by mechanical equipment.

7 **[BE] 304.12 ((304.11)) Guards.** Guards shall be provided where various components that
8 require service and roof hatch openings are located within 10 feet (3048 mm) of a roof edge or
9 open side of a walking surface and such edge or open side is located more than 30 inches (762
10 mm) above the floor, roof, or grade below. The guard shall extend not less than 30 inches (762
11 mm) beyond each end of components that require service. The top of the guard shall be located
12 not less than 42 inches (1067 mm) above the elevated surface adjacent to the guard. The guard
13 shall be constructed so as to prevent the passage of a 21-inch-diameter (533 mm) sphere and
14 shall comply with the loading requirements for guards specified in the *International Building*
15 *Code*.

16 **Exception:** Guards are not required where permanent fall arrest/restraint anchorage
17 connector devices that comply with ANSI/ASSE Z 359.1 are affixed for use during the entire
18 lifetime of the roof covering. The devices shall be re-evaluated for possible replacement
19 when the entire roof covering is replaced. The devices shall be placed not more than 10 feet
20 (3048 mm) on center along hip and ridge lines and placed not less than 10 feet (3048 mm)
21 from roof edges and the open sides of walking surfaces.

1 **304.13** (~~304.12~~) **Area served.** Appliances serving different areas of a building other than where
2 they are installed shall be permanently marked in an *approved* manner that uniquely identifies
3 the *appliance* and the area it serves.

4 SECTION 306

5 ACCESS AND SERVICE SPACE

6 * * *

7 **306.3.1 Electrical requirements.** A luminaire controlled by a switch located at the required
8 passageway opening and a receptacle outlet shall be provided at or near the *appliance*
9 location in accordance with the *Seattle Electrical Code* (~~NEPA 70~~).

10 * * *

11 **306.4.1 Electrical requirements.** A luminaire controlled by a switch located at the required
12 passageway opening and a receptacle outlet shall be provided at or near the *appliance*
13 location in accordance with the *Seattle Electrical Code* (~~NEPA 70~~).

14 **306.5 Equipment and appliances on roofs or elevated structures.** Where *equipment or*
15 appliances requiring access (~~or appliances~~) are located on an elevated structure or the roof of a
16 building such that personnel will have to climb higher than 16 feet (4877 mm) above grade to
17 access such equipment or appliances, an interior or exterior means of access shall be provided.
18 Such access shall not require climbing over obstructions greater than 30 inches (762 mm) in
19 height or walking on roofs having a slope greater than 4 units vertical in 12 units horizontal (33-
20 percent slope). Such access shall not require the use of portable ladders. Where access involves
21 climbing over parapet walls, the height shall be measured to the top of the parapet wall.
22 Permanent ladders installed to provide the required access shall comply with the following
23 minimum design criteria:

1 **[W]1.** The side railing shall extend above the parapet or roof edge not less than ~~((30))~~ 42
2 inches ~~((762))~~ 1067 mm).

3 **[W]2.** Ladders shall have rung spacing not to exceed ~~((14))~~ 12 inches ~~((356))~~ 305 mm) on
4 center. The uppermost rung shall be not greater than 24 inches (610 mm) below the upper
5 edge of the roof hatch, roof or parapet, as applicable.

6 **[W]3.** Ladders shall have a toe spacing not less than ~~((6))~~ 7 inches ~~((152))~~ 178 mm) deep.

7 4. There shall be not less than 18 inches (457 mm) between rails.

8 5. Rungs shall have a diameter not less than 0.75-inch (19 mm) and be capable of
9 withstanding a 300-pound (136.1 kg) load.

10 6. Ladders over 30 feet (9144 mm) in height shall be provided with offset sections and
11 landings capable of withstanding 100 pounds per square foot (488.2 kg/m²). Landing
12 dimensions shall be not less than 18 inches (457 mm) and not less than the width of the
13 ladder served. A guard rail shall be provided on all open sides of the landing.

14 7. Climbing clearance. The distance from the centerline of the rungs to the nearest permanent
15 object on the climbing side of the ladder shall be not less than 30 inches (762 mm)
16 measured perpendicular to the rungs. This distance shall be maintained from the point of
17 ladder access to the bottom of the roof hatch. A minimum clear width of 15 inches (381
18 mm) shall be provided on both sides of the ladder measured from the midpoint of and
19 parallel with the rungs except where cages or wells are installed.

20 8. Landing required. The ladder shall be provided with a clear and unobstructed bottom
21 landing area having a minimum dimension of 30 inches (762 mm) by 30 inches (762 mm)
22 centered in front of the ladder.

23 9. Ladders shall be protected against corrosion by *approved* means.

1 10. Access to ladders shall be provided at all times.

2 **Interpretation:** Item 10 allows access to ladders to be restricted to authorized personnel, and
3 prohibits storage that blocks or restricts access to the ladder.

4 Catwalks installed to provide the required access shall be not less than 24 inches (610 mm)
5 wide and shall have railings as required for service platforms.

6 **Exception:** This section shall not apply to Group R-3 occupancies.

7 * * *

8 **306.5.2 Electrical requirements.** A receptacle outlet shall be provided at or near the
9 *equipment* location in accordance with the Seattle Electrical Code ((NFPA-70)).

10 **[W]306.6 Appliances above ceilings.** Appliances that are located above the ceiling shall be
11 accessible for inspection, service, and repair without removing permanent construction.

12 Appliances shall be accessible from an access panel or removable ceiling tile with minimum
13 nominal dimensions of 24 inches x 24 inches (609mm x 609mm).

14 The appliance is not required to be removable or replaceable through the access panel or
15 removable ceiling tile. The appliance may be removed or replaced by removing the ceiling or
16 wall assemblies adjacent to the appliances as long as they are not permanent construction.

17 **Exception:**

18 1. This section shall not apply to replacement appliances installed in existing compartments
19 and alcoves where the working space clearances are in accordance with the equipment or
20 appliance manufacturer's installation instructions.

21 2. A smaller access panel or removal ceiling tile shall be permitted when allowed by the
22 equipment or appliance manufacturer installation instructions.

1 unit are manifolded together for condensate drainage, the pipe or tubing shall be sized in
2 accordance with Table 307.2.2.

**TABLE 307.2.2
CONDENSATE DRAIN SIZING**

EQUIPMENT CAPACITY	MINIMUM CONDENSATE PIPE DIAMETER
Up to 20 tons of refrigeration	$\frac{3}{4}$ inch
Over 20 tons to 40 tons of refrigeration	1 inch
Over 40 tons to 90 tons of refrigeration	$1\frac{1}{4}$ inch
Over 90 tons to 125 tons of refrigeration	$1\frac{1}{2}$ inch
Over 125 tons to 250 tons of refrigeration	2 inch

1 inch = 25.4 mm, 1 ton = 3.517 kW.

3 **307.2.3 Auxiliary and secondary drain systems.** In addition to the requirements of Section
4 307.2.1, where damage to any building components could occur as a result of overflow from the
5 *equipment* primary condensate removal system, one of the following auxiliary protection
6 methods shall be provided for each cooling coil or fuel-fired *appliance* that produces condensate:

- 7 1. An auxiliary drain pan with a separate drain shall be provided under the coils on which
8 condensation will occur. The auxiliary pan drain shall discharge to a conspicuous point
9 of disposal to alert occupants in the event of a stoppage of the primary drain. The pan
10 shall have a minimum depth of $1\frac{1}{2}$ inches (38 mm), shall be not less than 3 inches (76
11 mm) larger than the unit, or the coil dimensions in width and length and shall be
12 constructed of corrosion-resistant material. Galvanized sheet steel pans shall have a
13 minimum thickness of not less than 0.0236 inch (0.6010 mm) (No. 24 gage).
14 Nonmetallic pans shall have a minimum thickness of not less than 0.0625 inch (1.6
15 mm).

- 1 2. A separate overflow drain line shall be connected to the drain pan provided with the
2 *equipment*. Such overflow drain shall discharge to a conspicuous point of disposal to
3 alert occupants in the event of a stoppage of the primary drain. The overflow drain line
4 shall connect to the drain pan at a higher level than the primary drain connection.
- 5 3. An auxiliary drain pan without a separate drain line shall be provided under the coils
6 on which condensate will occur. Such pan shall be equipped with a water-level
7 detection device conforming to UL 508 that will shut off the *equipment* served prior to
8 overflow of the pan. The auxiliary drain pan shall be constructed in accordance with
9 Item 1 of this section.
- 10 4. A water-level detection device conforming to UL 508 shall be provided that will shut
11 off the *equipment* served in the event that the primary drain is blocked. The device
12 shall be installed in the primary drain line, the overflow drain line, or in the equipment-
13 supplied drain pan, located at a point higher than the primary drain line connection and
14 below the overflow rim of such pan.

15 **WExceptions:**

- 16 1. Fuel-fired appliances that automatically shut down operation in the event of a stoppage
17 in the condensate drainage system.
- 18 2. Unducted fan coil units where there is no factory option available for water-level
19 detection devices and which are installed directly within the occupied space.

20 **307.2.3.1 Water-level monitoring devices.** On downflow units and all other coils that do
21 not have a secondary drain or provisions to install a secondary or auxiliary drain pan, a
22 water-level monitoring device shall be installed inside the primary drain pan. This device

1 shall shut off the *equipment* served in the event that the primary drain becomes restricted.
2 Devices installed in the drain line shall not be permitted.

3 **Exception:** Water-level monitoring devices are not required for unducted fan coil
4 units where there is no factory option available for water-level detection devices and
5 the units are installed directly within the occupied space.

6 **307.2.4 Traps.** Condensate drains shall be trapped as required by the *equipment* or *appliance*
7 manufacturer.

8 **[W]307.2.4.1 Ductless mini-split system traps.** Ductless mini-split equipment that
9 produces condensate shall be provided with an inline check valve located in the drain
10 line, ~~((or))~~ a trap, or other means of condensate drainage in accordance with the
11 manufacturer's instructions.

12 * * *

13 SECTION 309

14 TEMPERATURE CONTROL

15 **[BG] 309.1 Space-heating systems.** Interior spaces intended for human occupancy shall be
16 provided with active or passive space-heating systems capable of maintaining an average indoor
17 temperature of not less than 68°F (20°C) at a point 3 feet (914 mm) above floor ~~((on the design~~
18 ~~heating day))~~ when the outside temperature is 24°F. The installation of portable space heaters
19 shall not be used to achieve compliance with this section.

20 **Exceptions:**

- 21 1. Interior spaces where the primary purpose is not associated with human comfort.
- 22 2. Group F, H, S and U occupancies.

1 **401.2.2 Ambulatory care facilities and Group I-2 occupancies.** Ambulatory care facilities
2 and Group I-2 occupancies shall be ventilated by mechanical means in accordance with
3 Section 407.

4 **401.2.3 All other occupancies.** Ventilation in all other occupancies shall be provided by
5 natural means in accordance with Section 402 or by mechanical means in accordance with
6 Sections ~~((403))~~ 403.1 to 403.7~~((Where the air infiltration rate in a dwelling unit is less than~~
7 ~~5 air changes per hour when tested with a blower door at a pressure of 0.2 inch water column~~
8 ~~(50 Pa) in accordance with Section R402.4.1.2 of the International Energy Conservation~~
9 ~~Code, the dwelling unit shall be ventilated by mechanical means in accordance with Section~~
10 ~~403. Ambulatory care facilities and Group I 2 occupancies shall be ventilated by mechanical~~
11 ~~means in accordance with Section 407)).~~

12 **[W]401.3 When required.** Group R occupancies shall be vented continuously or intermittently
13 in accordance with Section 403.4. Ventilation in all other occupancies shall be provided during
14 the periods that the room or space is occupied.

15 **401.4 Intake opening location.** Air intake openings shall comply with all of the following:

- 16 1. Intake openings shall be located not less than 10 feet (3048 mm) from lot lines or buildings
17 on the same lot. Where openings front on a street or public way, the distance shall be
18 measured from the opposite side of the street or public way.
- 19 2. Mechanical and gravity *outdoor air* intake openings shall be located not less than 10 feet
20 (3048 mm) horizontally from any hazardous or noxious contaminant source, such as vents,
21 streets, alleys, parking lots and loading docks, except as specified in Item 3 or Section
22 501.3.1. *Outdoor air* intake openings shall be permitted to be located less than 10 feet
23 (3048 mm) horizontally from streets, alleys, parking lots and loading docks provided that

1 the openings are located not less than 25 feet (7620 mm) vertically above such locations.

2 Where openings front on a street or public way, the distance shall be measured from the
3 closest edge of the street or public way. The exhaust from a bathroom, clothes dryer or
4 kitchen in a dwelling shall not be considered to be a hazardous or noxious contaminant.

5 **Exception:** Enclosed parking garage and repair garage intakes are permitted to be located
6 less than 10 feet horizontally of the street, alley, parking lots and loading docks.

7 3. Intake openings shall be located not less than 3 feet (914 mm) below contaminant sources
8 where such sources are located within 10 feet (3048 mm) of the opening.

9 4. Intake openings on structures in flood hazard areas shall be at or above the elevation
10 required by Section 1612 of the *International Building Code* for utilities and attendant
11 equipment.

12 **5. Intake openings shall not be located:**

13 **5.1. In a crawl space;**

14 **5.2. Less than one foot (305 mm) above a roof, adjacent grade, or other surface directly**
15 **below the intake; or**

16 **5.3. Under a deck having a surface height less than three feet above grade or other surface**
17 **directly below the intake.**

18 **Interpretation:** For purposes of this section, lot line includes any property line separating one
19 lot from another lot, but does not include any property line separating a lot from a public
20 street or alley right-of-way.

21 * * *

22 **401.7 Compliance and commissioning.** Compliance with Sections 402 and 403.1 through 403.4
23 shall be demonstrated through engineering calculations. Documentation of calculations shall be

1 submitted on the permit plan sets. Testing and commissioning shall be performed and
2 documented in accordance with the *International Energy Conservation Code*.

3 SECTION 402

4 NATURAL VENTILATION

5 **[BG] 402.1 Natural ventilation.** *Natural ventilation* of an occupied space shall be through
6 windows, doors, louvers or other openings to the outdoors. The operating mechanism for such
7 openings shall be provided with ready access so that the openings are readily controllable by the
8 building occupants.

9 **Exception:** Automatically controlled natural ventilation systems do not require ready access
10 and control by building occupants.

11 * * *

12 SECTION 403

13 MECHANICAL VENTILATION

14 **[W] 403.1 Ventilation system.** Mechanical ventilation shall be provided by a method of supply
15 air and return or *exhaust air* (~~except that mechanical ventilation air requirements for Group R-2,~~
16 ~~R-3 and R-4 occupancies three stories and less in height above grade plane shall be provided by~~
17 ~~an exhaust system, supply system or combination thereof~~). The amount of supply air shall be
18 approximately equal to the amount of return and *exhaust air*. The system shall not be prohibited
19 from producing negative or positive pressure. The system to convey *ventilation air* shall be
20 designed and installed in accordance with Chapter 6.

21 **[W] 403.2 Outdoor air required.** The minimum outdoor (~~air~~) flow rate shall be determined in
22 accordance with Section 403.3.

1 **[W] Exceptions:**

2 1. Where the *registered design professional* demonstrates that an engineered ventilation
3 system design will prevent the maximum concentration of contaminants from exceeding
4 that obtainable by the rate of *outdoor air* ventilation determined in accordance with Section
5 403.3, the minimum required rate of *outdoor air* shall be reduced in accordance with such
6 engineered system design.

7 2. Alternate systems designed in accordance with ASHRAE Standard 62.1 Section 6.2,
8 Ventilation Rate Procedure, shall be permitted.

9 **[W]403.2.1 Recirculation of air.** The ~~((outdoor))~~ air required by Section 403.3 shall not be
10 recirculated. Air in excess of that required by Section 403.3 shall not be prohibited from
11 being recirculated as a component of supply air to building spaces, except that:

12 1. Ventilation air shall not be recirculated from one *dwelling* to another or to dissimilar
13 occupancies.

14 2. Supply air to a swimming pool and associated deck areas shall not be recirculated
15 unless such air is dehumidified to maintain the relative humidity of the area at 60
16 percent or less. Air from this area shall not be recirculated to other spaces where
17 ~~((more than))~~ 10 percent or more of the resulting supply airstream consists of air
18 recirculated from these spaces.

19 3. Where mechanical exhaust is required by Note b in Table 403.3.1.1, recirculation of air
20 from such spaces shall be prohibited. ~~((Recirculation of air that is contained~~
21 ~~completely within such spaces shall not be prohibited. Where recirculation of air is~~
22 ~~prohibited, a))~~ All air supplied to such spaces shall be exhausted, including any air in
23 excess of that required by Table 403.3.1.1.

1 required rate of outdoor airflow to the *breathing zone*. The occupant load utilized for
2 design of the ventilation system shall be not less than the number determined from the
3 estimated maximum occupant load rate indicated in Table 403.3.1.1. Ventilation rates for
4 occupancies not represented in Table 403.3.1.1 shall be those for a listed *occupancy*
5 classification that is most similar in terms of occupant density, activities and building
6 construction; or shall be determined by an *approved* engineering analysis. The ventilation
7 system shall be designed to supply the required rate of *ventilation air* continuously during
8 the period the building is occupied, except as otherwise stated in other provisions of the
9 code.

10 With the exception of smoking lounges, the ventilation rates in Table 403.3.1.1 are
11 based on the absence of smoking in occupiable spaces. Where smoking is anticipated in a
12 space other than a smoking lounge, the ventilation system serving the space shall be
13 designed to provide ventilation over and above that required by Table 403.3.1.1 in
14 accordance with accepted engineering practice.

15 **[W] Exception:** (~~The occupant load is not required to be determined based on the~~
16 ~~estimated maximum occupant load rate indicated in Table 403.3.1.1 where *approved*~~
17 ~~statistical data document the accuracy of an alternate anticipated occupant density.~~)

18 Where occupancy density is known and documented in the plans, the outside air rate
19 may be based on the design occupant density. Under no circumstance shall the
20 occupancies used result in outside air less than one-half that resulting from
21 application of Table 403.3.1.1 estimated maximum occupancy rates.

22 * * *

1
 2

[W] TABLE 403.3.1.1

MINIMUM VENTILATION RATES

OCCUPANCY CLASSIFICATION	OCCUPANT DENSITY #/1000 FT^{2 a}	PEOPLE OUTDOOR AIRFLOW RATE IN BREATHING ZONE, R_p CFM/PERSON	AREA OUTDOOR AIRFLOW RATE IN BREATHING ZONE, R_a CFM/FT^{2 a}	EXHAUST AIRFLOW RATE CFM/FT^{2 a}
Correctional facilities				
Booking/waiting	50	7.5	0.06	—
Cells without plumbing fixtures	25	5	0.12	—
with plumbing fixtures ^{g,k}	25	5	0.12	1.0
Day room	30	5	0.06	—
Dining halls (see food and beverage service)	—	—	—	—
Guard stations	15	5	0.06	—
Dry cleaners, laundries				
Coin-operated dry cleaner	20	15	—	—
Coin-operated laundries	20	7.5	0.06	—
Commercial dry cleaner	30	30	—	—
Commercial laundry	10	25	—	—
Storage, pick up	30	7.5	0.12	—
Education				
Art classroom ^g	20	10	0.18	0.7
Auditoriums	150	5	0.06	—
Classrooms (ages 5-8)	25	10	0.12	—
Classrooms (age 9 plus)	35	10	0.12	—
Computer lab	25	10	0.12	—
Corridors (see public spaces)	—	—	—	—
Day care (through age 4)	25	10	0.18	—
Lecture classroom	65	7.5	0.06	—

Lecture hall (fixed seats)	150	7.5	0.06	—
Locker/dressing rooms ^{g,k}	—	—	—	0.25
Media Center	25	10	0.12	—
Multiuse assembly	100	7.5	0.06	—
Music/theater/dance	35	10	0.06	—
Science laboratories ^{g,k}	25	10	0.18	1.0
((Smoking lounges ^b	70	60		—))
Sports locker rooms ^{g,k}	—	—	—	0.5
Wood/metal shops ^{g,k}	20	10	0.18	0.5
Food and beverage service				
Bars, cocktail lounges	100	7.5	0.18	—
Cafeteria, fast food	100	7.5	0.18	—
Dining rooms	70	7.5	0.18	—
Kitchens (cooking) ^b	—	—	—	0.7
Hotels, motels, resorts and dormitories				
Multipurpose assembly	<u>120</u>	5	0.06	—
Bathrooms/toilet-private ^{g,k}	—	—	—	25/50 ^f
Bedroom/living room	<u>10</u>	5	0.06	—
Conference/meeting	<u>50</u>	5	0.06	—
Dormitory sleeping areas	<u>20</u>	5	0.06	—
Gambling casinos	<u>120</u>	7.5	0.18	—
Lobbies/prefunction	<u>30</u>	7.5	0.06	—
Multipurpose assembly		5	0.06	—
Offices				
Conference rooms	50	5	0.06	—
[W] Kitchenettes ^m	—	—	—	0.30
Main entry lobbies	10	5	0.06	—
Office spaces	5	5	0.06	—
Reception areas	30	5	0.06	—
Telephone/data entry	60	5	0.06	—
Private dwellings, single and multiple				
Garages, common for multiple units ^b	—	—	—	0.75

Kitchens ^b	—	—	—	25/100 ^f
[W]Living areas ^c	Based upon number of bedrooms. First bedroom, 2; each additional bedroom, 1	((0.35 ACH but not less than 15 cfm/person)) <u>See Tables 403.4.1 & 403.4.5.1</u>	—	—
[W]Toilet rooms, (and) bathrooms ^k and laundry areas ^{g, i}	—	—	—	20/50 ^f
Public spaces				
[W] Corridors, serving other than Group R occupancies	—	—	0.06	—
[W]Corridors, serving Group R dwelling or sleeping units with whole house exhaust system	—	—	0.12	—
[W]Corridors, serving Group R dwelling or sleeping units with other than whole house exhaust system	—	—	0.06	—
Elevator car	—	—	—	1.0
[W] Elevator lobbies in parking garages ^o	—	—	1.0 ^o	—
Shower room (per shower head) ^{g, k}	—	—	—	50/20 ^f
(Smoking lounges ^b	70	60	—	—))
Toilet rooms — public ^{g, k}	—	—	—	50/70 ^e
Places of religious worship	120	5	0.06	—
Courtrooms	70	5	0.06	—
Legislative chambers	50	5	0.06	—
Libraries	10	5	0.12	—
Museums (children's)	40	7.5	0.12	—
Museums/galleries	40	7.5	0.06	—
Retail stores, sales floors and showroom floors				
Dressing rooms	—	—	—	0.25

Mall common areas	40	7.5	0.06	—
Sales	15	7.5	0.12	—
Shipping and receiving	—	—	0.12	—
((Smoking lounges^b	70	60	—	(—))
Storage rooms	—	—	0.12	—
Warehouses (see storage)	—	—	—	—
Specialty shops				
Automotive motor-fuel dispensing stations ^b	—	—	—	1.5
Barber	25	((7.5)) <u>20</u>	0.06	0.5
Beauty salons ^b	25	20	0.12	0.6
Nail salons ^{b,h}	25	20	0.12	0.6
Embalming room ^b	—	—	—	2.0
Pet shops (animal areas) ^b	10	7.5	0.18	0.9
Supermarkets	8	7.5	0.06	—
Sports and amusement				
Bowling alleys (seating areas)	40	10	0.12	—
Disco/dance floors	100	20	0.06	—
Game arcades	20	7.5	0.18	—
[W]Gym, stadium, arena (play area) ⁱ	—	—	0.30	—
Health club/aerobics room	40	20	0.06	—
Health club/weight room	10	20	0.06	—
Ice arenas without combustion engines	—	—	0.30	0.5
Spectator areas	150	7.5	0.06	—
Swimming pools (pool and deck area)	—	—	0.48	—
Storage				
[W] Janitor closets, trash rooms, recycling rooms	—	—	—	<u>1.0</u>
Repair garages ^d ((, enclosed parking garages^{b,d}))	—	—	—	0.75

<u>Enclosed loading docks^d</u>	==	==	==	<u>1.5</u>
<u>Enclosed parking garages^{b, d}</u>	60	==	==	==
<u>Ticket booths (within enclosed parking garages)^l</u>	==	==	==	<u>1.5</u>
<u>[W] Storage rooms, chemical</u>				
<u>Warehouses</u>	—	—	0.06	—
<u>Non-retail storage spaces >100 sf^k</u>	==	==	<u>0.06</u>	==
Theaters				
Auditoriums (see education)	—	—	—	—
Lobbies	150	5	0.06	—
Stages, studios	70	10	0.06	—
Ticket booths	60	5	0.06	—
Transportation				
Platforms	100	7.5	0.06	—
Transportation waiting	100	7.5	0.06	—
Workrooms				
Bank vaults/safe deposit	5	5	0.06	—
Computer (without printing)	4	5	0.06	—
Copy, printing rooms	4	5	0.06	—
Darkrooms	—	—	—	1.0
<u>[W] Freezer and refrigerated spaces (<50°F)</u>	<u>0</u>	<u>10</u>	<u>0</u>	<u>0</u>
Meat processing ^c	10	15	—	—
Pharmacy (prep. area)	10	5	0.18	—
Photo studios	10	5	0.12	—

- 1 For SI: 1 cubic foot per minute = 0.0004719 m³/s, 1 ton = 908 kg, 1 cubic foot per minute per
2 square foot = 0.00508 m³/(s • m²),
3 °C = [(°F) -32]/1.8, 1 square foot = 0.0929 m².
4 a. Based upon *net occupiable floor area*.

1 b. Mechanical exhaust required and the recirculation of air from such spaces is prohibited.

2 Recirculation of air that is contained completely within such spaces shall not be prohibited
3 (see Section 403.2.1, Item 3).

4 c. Spaces unheated or maintained below 50°F are not covered by these requirements unless
5 the occupancy is continuous.

6 d. Ventilation systems (~~(in enclosed parking garages)~~) shall comply with Section 404.

7 e. Rates are per water closet or urinal. The higher rate shall be provided where the exhaust
8 system is designed to operate intermittently. The lower rate shall be permitted only where
9 the exhaust system is designed to operate continuously while occupied.

10 f. Rates are per room unless otherwise indicated. The higher rate shall be provided where the
11 exhaust system is designed to operate intermittently. The lower rate shall be permitted only
12 where the exhaust system is designed to operate continuously while occupied.

13 **[W]** g. Mechanical exhaust is required and recirculation from such spaces is prohibited
14 (~~(except that recirculation shall be permitted where the resulting supply airstream consists~~
15 ~~of not more than 10 percent air recirculated from these spaces. Recirculation of air that is~~
16 ~~contained completely within such spaces shall not be prohibited (see Section 403.2.1, Items~~
17 ~~2 and 4).))~~

18 h. For nail salons, each manicure and pedicure station shall be provided with a *source*
19 *capture system* capable of exhausting not less than 50 cfm per station. Exhaust inlets shall
20 be located in accordance with Section 502.20. Where one or more required source capture
21 systems operate continuously during occupancy, the exhaust rate from such systems shall
22 be permitted to be applied to the exhaust flow rate required by Table 403.3.1.1 for the nail
23 salon.

1 [W] i. A laundry area within a kitchen or bathroom is not required to have local exhaust. For
2 the laundry area to qualify as being within the kitchen, the laundry room door must open
3 directly into the kitchen and not into an adjacent corridor. Where there are doors that
4 separate the laundry area from the kitchen or bathroom the door shall be louvered.

5 [W] j. When combustion equipment is intended to be used on the playing surface, additional
6 dilution ventilation and/or source control shall be provided.

7 k. Transfer air permitted in accordance with Section 403.2.2. For non-retail storage areas,
8 transfer air is also permitted from an adjacent open parking garage, or an enclosed parking
9 garage or loading dock that is mechanically ventilated in accordance with Section 404.

10 l. This space shall be maintained at a positive pressure. See Section 404.3.

11 [W] m. Kitchenettes require exhaust when they contain a domestic cooking appliance range
12 or oven that is installed in accordance with Table 507.1.2. Kitchenettes that only contain a
13 microwave oven are not required to have mechanical exhaust. A kitchenette may not
14 contain commercial cooking appliances that require Type I or Type II exhaust as these
15 occupancies are required to be exhausted to the kitchen category in Table 403.3.1.1.

16 n. For occupied freezer and refrigerated spaces utilize proposed occupant density for outdoor
17 airflow rates.

18 o. The required outdoor airflow rate shall be introduced directly into such spaces or into the
19 occupied spaces from which the air is transferred or a combination of both.

20 * * *

21 **403.3.1.4 Variable air volume system control.** Variable air volume air distribution
22 systems, other than those designed to supply only 100-percent *outdoor air*, shall be
23 provided with controls to regulate the flow of *outdoor air*. Such control system shall be

1 designed to maintain the flow rate of *outdoor air* at a rate of not less than that required by
2 Section 403.3 over the entire range of supply air operating rates. Calculations and a
3 description of controls operation shall be submitted with the permit drawings.

4 * * *

5 **[W]403.3.2 Group R-2, R-3 and R-4 occupancies, three stories and less.** ~~((The design of~~
6 ~~local exhaust systems and ventilation systems for outdoor air in Group R-2, R-3 and R-4~~
7 ~~occupancies three stories and less in height above grade plane shall comply with Sections~~
8 ~~403.3.2.1 through 403.3.2.3.)) This section is not adopted. See Section 403.4.~~

9 ~~((**403.3.2.1 Outdoor air for dwelling units.** An outdoor air ventilation system consisting~~
10 ~~of a mechanical exhaust system, supply system or combination thereof shall be installed~~
11 ~~for each dwelling unit. Local exhaust or supply systems, including outdoor air ducts~~
12 ~~connected to the return side of an air handler, are permitted to serve as such a system.~~
13 ~~The outdoor air ventilation system shall be designed to provide the required rate of~~
14 ~~outdoor air continuously during the period that the building is occupied. The minimum~~
15 ~~continuous outdoor airflow rate shall be determined in accordance with Equation 4-9.~~

16 ~~**(Equation 4-9)**~~

17 ~~where:~~

18 ~~QOA = outdoor airflow rate, cfm~~

19 ~~A_{floor} = floor area, ft²~~

20 ~~N_{br} = number of bedrooms; not to be less than one~~

21 ~~**Exception:** The outdoor air ventilation system is not required to operate continuously~~
22 ~~where the system has controls that enable operation for not less than 1 hour of each 4-~~

1 hour period. The average outdoor air flow rate over the 4-hour period shall be not less
2 than that prescribed by Equation 4-9.

3 ~~403.3.2.2 Outdoor air for other spaces.~~ Corridors and other common areas within the
4 conditioned space shall be provided with outdoor air at a rate of not less than 0.06 cfm
5 per square foot of floor area.

6 ~~403.3.2.3 Local exhaust.~~ Local exhaust systems shall be provided in kitchens, bathrooms
7 and toilet rooms and shall have the capacity to exhaust the minimum airflow rate
8 determined in accordance with Table 403.3.2.3.)

9 [W]((TABLE 403.3.2.3

10 ~~MINIMUM REQUIRED LOCAL EXHAUST RATES~~

11 ~~FOR GROUP R-2, R-3, AND R-4 OCCUPANCIES~~

AREA TO BE EXHAUSTED	EXHAUST RATE CAPACITY
Kitchens	100 cfm intermittent or 25 cfm continuous
Bathrooms and toilet rooms	50 cfm intermittent or 20 cfm continuous

12 For SI: 1 cubic foot per minute = 0.0004719 m³/s.)

13 [W] 403.4 Ventilation systems for Group R occupancies. Each dwelling unit or sleeping unit
14 shall be equipped with local exhaust and whole house ventilation systems and shall comply with
15 Sections 403.4.1 through 403.4.11. All occupied spaces, including public corridors, other than
16 the Group R dwelling and sleeping unit, that support the Group R occupancy shall meet the
17 ventilation requirements of Section 402 or Sections 403.1 to 403.7.

18 403.4.1 Minimum ventilation performance. Ventilation systems shall be designed and
19 installed to satisfy the ventilation requirements of Table 403.3.1.1 or Table 403.4.1.
20 Breathing zone ventilation rates from Table 403.3.1.1 shall be calculated per Section

1 403.3.1.1 and corrected per zone air distribution effectiveness requirements per Section
2 403.3.1.2.

3 **Table 403.4.1**

4 **Ventilation Rates for All Group R Private Dwellings, Single and Multiple**

5 (Continuously Operating Systems)

<u>Floor Area</u>	<u>Bedrooms¹</u>				
<u>(ft²)</u>	<u>0-1</u>	<u>2-3</u>	<u>4-5</u>	<u>6-7</u>	<u>≥5</u>
<u><500</u>	<u>30</u>	<u>40</u>	<u>45</u>	<u>55</u>	<u>60</u>
<u>500 - 1000</u>	<u>45</u>	<u>55</u>	<u>60</u>	<u>70</u>	<u>75</u>
<u>1001 - 1500</u>	<u>60</u>	<u>70</u>	<u>75</u>	<u>85</u>	<u>90</u>
<u>1501 - 2000</u>	<u>75</u>	<u>85</u>	<u>90</u>	<u>100</u>	<u>105</u>
<u>2001 - 2500</u>	<u>90</u>	<u>100</u>	<u>105</u>	<u>115</u>	<u>120</u>
<u>2501 - 3000</u>	<u>105</u>	<u>115</u>	<u>120</u>	<u>130</u>	<u>135</u>
<u>3001 - 3500</u>	<u>120</u>	<u>130</u>	<u>135</u>	<u>145</u>	<u>150</u>
<u>>3500</u>	<u>135</u>	<u>145</u>	<u>150</u>	<u>160</u>	<u>165</u>

6 ¹Ventilation rates in table are minimum outdoor airflow rates measured in cfm.

7 **403.4.2 Control and operation.** Controls for and operation of ventilation systems shall
8 comply with this section.

9 **Exception:** Engineered central ventilation systems serving dwelling units or sleeping
10 units are not required to have individual controls for each dwelling unit or sleeping unit
11 when designed for continuous operation and approved by the code official.

12 1. Location of controls. Controls for all ventilation systems shall be readily accessible by
13 the occupant.

14 2. Instructions. Operating instructions for whole house ventilation systems shall be
15 provided to the occupant by the installer of the system.

16 3. Local exhaust ventilation systems. Local exhaust ventilation systems shall be
17 controlled by manual switches, dehumidistats, timers, or other approved means.

1 4. Continuous whole house ventilation systems. Continuous whole house ventilation
2 systems shall operate continuously and be equipped with an override control. A “fan
3 on” switch shall be permitted as an override control. Controls shall be capable of
4 operating the ventilation system without energizing other energy-consuming
5 appliances. A clearly visible label shall be affixed to the controls that reads “Whole
6 House Ventilation (see operating instructions).”

7 5. Intermittent whole house ventilation systems. Intermittent whole house ventilation
8 systems shall comply with the following:

9 5.1 They shall be capable of operating intermittently and continuously.

10 5.2 They shall have controls capable of operating the exhaust fans, forced-air system
11 fans, or supply fans without energizing other energy-consuming appliances.

12 5.3 The ventilation rate shall be adjusted according to the exception in Section
13 403.4.5.1.

14 5.4 The system shall be designed so that it can operate automatically based on the type
15 of control timer installed.

16 5.5 The intermittent mechanical ventilation system shall operate at least one hour out of
17 every four.

18 5.6 The system shall have a manual control and automatic control, such as a 24-hour
19 clock timer.

20 5.7 At the time of final inspection, the automatic control shall be set to operate the
21 whole house fan according to the schedule used to calculate the whole house fan sizing.

22 5.8 A label shall be affixed to the control that reads “Whole House Ventilation (see
23 operating instructions).”

1 **Exception:** Engineered central ventilation systems serving dwelling units or sleeping
2 units are not required to have individual controls for each dwelling unit or sleeping unit
3 when designed for continuous operation and approved by the *code official*.

4 **403.4.3 Outdoor air intake locations.** *Outdoor air* intakes shall be classified as either
5 operable openings or mechanical air intakes and shall be located per the following criteria.

6 The intake locations for operable openings and mechanical air intakes shall comply with the
7 following:

8 1. Openings for mechanical air intakes shall comply with Section 401.4. Operable
9 openings shall comply with Section 401.4 items 2 and 4 only.

10 2. Intake openings shall not be located closer than 10 feet from an appliance vent outlet
11 unless such vent outlet is 3 feet above the *outdoor air* inlet. The vent shall be permitted
12 to be closer if specifically allowed by Chapter 8 or by the International Fuel Gas Code.

13 3. Intake openings shall be located where they will not pick up objectionable odors,
14 fumes, or flammable vapors.

15 4. Intake openings shall be located where they will not take air from a hazardous or
16 unsanitary location.

17 5. Intake openings shall be located where they will not take air from a room or space
18 having a fuel-burning appliance.

19 6. Intake openings shall not be located closer than 10 feet from a vent opening of a
20 plumbing drainage system unless the vent opening is at least 3 feet above the air inlet.

21 7. Intake openings shall not be located where they will take air from an attic, crawl space,
22 or garage.

1 8. Intake openings shall not be located on asphalt roofs unless it is shown that no other
2 location is permissible. In such cases, the inlet opening shall be located a minimum of 2
3 feet from the nearest surface of the asphalt roofing measured from the intake opening.

4 **403.4.4 Local exhaust ventilation requirements.** Local exhaust ventilation systems shall
5 exhaust at least the volume of air required for exhaust in Table 403.3.1.1 Exhaust shall be
6 provided in each kitchen, bathroom, water closet, laundry area, indoor swimming pool, spa,
7 and other rooms where water vapor or cooking odor is produced. Local exhaust ventilation
8 ducts shall terminate outdoors.

9 **403.4.4.1 Local exhaust systems.** Exhaust systems shall be designed and installed to
10 meet all of the criteria below:

- 11 1. Local exhaust shall be discharged outdoors.
- 12 2. Exhaust outlets shall comply with Section 501.3.
- 13 3. Pressure equalization shall comply with Section 501.4.
- 14 4. Exhaust ducts in systems which are designed to operate intermittently shall be
15 equipped with backdraft dampers.
- 16 5. All exhaust ducts in unconditioned spaces shall be insulated to a minimum of R-4.
- 17 6. Terminal outlet elements shall have at least the equivalent net free area of the
18 ductwork.
- 19 7. Terminal outlet elements shall be screened or otherwise protected as required by
20 Section 501.3.2.
- 21 8. Exhaust fans in separate dwelling units or sleeping units shall not share common
22 exhaust ducts unless the system is engineered for this operation.

1 9. Where permitted by Chapter 5, multiple local exhaust ducts may be combined. If
2 more than one of the exhaust fans in a dwelling unit or sleeping unit shares a
3 common exhaust duct then each exhaust fan shall be equipped with a backdraft
4 damper to prevent the recirculation of exhaust air from one room to another room
5 via the exhaust ducting system.

6 **403.4.4.2 Local exhaust fans.** Exhaust fan construction and sizing shall meet the
7 following criteria:

8 1. Exhaust fans shall be tested and rated in accordance with the airflow and sound
9 rating procedures of the Home Ventilating Institute (HVI 915, HVI Loudness
10 Testing and Rating Procedure; HVI 916, Airflow Test Procedure; and HVI 920,
11 Product Performance Certification Procedure

12 **Exception:** Where a range hood or down-draft exhaust fan used for local exhaust
13 for kitchens, the device is not required to be rated per these standards.

14 2. Fan airflow rating and duct systems shall be designed and installed to deliver at
15 least the exhaust airflow required.

16 3. Fan airflow rating and duct systems shall be designed and installed to deliver at
17 least the exhaust airflow required by Table 403.3.1.1 The airflows required refer to
18 the delivered airflow of the system as installed and tested using a flow hood, flow
19 grid, or other airflow measurement device.

20 **Exceptions:**

21 1. An exhaust airflow rating at a pressure of 0.25 in. w.g. may be used,
22 provided the duct sizing meets the prescriptive requirements of Table
23 403.4.4.2.

2. Where a range hood or down-draft exhaust fan is used to satisfy the local exhaust requirements for kitchens, the range hood or down draft exhaust shall not be less than 100 cfm at 0.10 in. w.g.

Table 403.4.4.2

Prescriptive Exhaust Duct Sizing

<u>Fan Tested cfm at 0.25 inches w.g.</u>	<u>Minimum Flex Diameter</u>	<u>Maximum Length in Feet</u>	<u>Minimum Smooth Diameter</u>	<u>Maximum Length in Feet</u>	<u>Maximum Elbows¹</u>
<u>50</u>	<u>4 inches</u>	<u>25</u>	<u>4 inches</u>	<u>70</u>	<u>3</u>
<u>50</u>	<u>5 inches</u>	<u>90</u>	<u>5 inches</u>	<u>100</u>	<u>3</u>
<u>50</u>	<u>6 inches</u>	<u>No Limit</u>	<u>6 inches</u>	<u>No Limit</u>	<u>3</u>
<u>80</u>	<u>4 inches²</u>	<u>NA</u>	<u>4 inches</u>	<u>20</u>	<u>3</u>
<u>80</u>	<u>5 inches</u>	<u>15</u>	<u>5 inches</u>	<u>100</u>	<u>3</u>
<u>80</u>	<u>6 inches</u>	<u>90</u>	<u>6 inches</u>	<u>No Limit</u>	<u>3</u>
<u>100</u>	<u>5 inches²</u>	<u>NA</u>	<u>5 inches</u>	<u>50</u>	<u>3</u>
<u>100</u>	<u>6 inches</u>	<u>45</u>	<u>6 inches</u>	<u>No Limit</u>	<u>3</u>
<u>125</u>	<u>6 inches</u>	<u>15</u>	<u>6 inches</u>	<u>No Limit</u>	<u>3</u>
<u>125</u>	<u>7 inches</u>	<u>70</u>	<u>7 inches</u>	<u>No Limit</u>	<u>3</u>

1. For each additional elbow, subtract 10 feet from length.

2. Flex ducts of this diameter are not permitted with fans of this size.

403.4.5 Whole house ventilation requirements. Each dwelling unit or sleeping unit shall be equipped with one of the following four types of mechanical whole house ventilation systems: A system using exhaust fans (see Section 403.4.6); A system integrated with forced-air systems (see Section 403.4.7); A system using supply fans (see Section 403.4.8); or a heat or energy recovery ventilation system (see Section 403.4.9). The whole house exhaust system is permitted to be one of the local exhaust systems required by Section 403.4.4 as long as the requirements of this section, in addition to the requirements of Section 403.4.4, are met.

^b Extrapolation beyond the table is prohibited.

Intermittent Mechanical Ventilation Airflow Calculation Examples:

Example #1: Calculating fan airflow based on Table 403.4.5.1 values:

An intermittently operated whole house fan that serves a dwelling unit with a continuous ventilation requirement of 30 CFM (from Table 403.3.1.1 or 403.4.1) is controlled to operate with an on-time of 3 hours and off-time of 1 hours throughout the day.

The minimum intermittent ventilation rate is calculated as follows:

Ventilation rate $Q_r = 30$ CFM (from Table 403.3.1.1 or 403.4.1)

Cycle time = 4 hours

(where: cycle time is equal to the on-time plus the off-time)

Run-time percentage = $3 / 4 = 75\%$

_____ (where: f is equal to the on-time divided by the cycle time)

Ventilation rate factor (F_v) 1.3 (from Table 403.4.5.1)

Final ventilation rate $Q_f = Q_r \times F_v = 30$ CFM \times 1.3 = 39

Example #2: Calculating fan airflow based on footnote a to Table 403.4.5.1:

An intermittently operated whole house fan that serves a dwelling unit with a continuous ventilation requirement of 30 CFM (from Table 403.3.1.1 or 403.4.1) is controlled to operate with an on-time of 1 hours and off-time of 3 hour throughout the day.

The minimum intermittent ventilation rate is calculated as follows:

Ventilation rate $Q_r = 30$ CFM (from Table 403.3.1.1 or 403.4.1)

Cycle time = 4 hours

_____ (where: cycle time is equal to the on-time plus the off-time)

Run-time percentage = $1/4 = 25\%$ (this is greater than 50%)

_____ (where: f is equal to the on-time divided by the cycle time)

1 Ventilation rate factor $F_v = 4$ (per footnote a of Table 403.4.5.1)

2 Final ventilation rate $Q_f = Q_r \times F_v = 30 \text{ CFM} \times 4 = 120 \text{ CFM}$

3 See ASHRAE 62.2 Appendix B for further explanation and examples.

4 **403.4.5.2 Whole house supply system general requirements.** Whole house ventilation
5 systems integrated with a forced-air system, systems using supply fans and systems using
6 a heat or energy recovery ventilation system shall comply with the following:

7 1. *Outdoor air* louvers shall be adequately sized for the required airflow and shall
8 comply with Section 401.5. *Outdoor air* intake locations shall comply with
9 mechanical air intake requirements of Section 403.4.3.

10 2. *Outdoor air* ducts for dedicated or central supply systems and exhaust ducts for
11 heat or energy recovery systems shall be provided with a means for balancing the
12 system to the required airflow via balance dampers or other devices.

13 3. *Outdoor air* ducts for dedicated or central systems shall be provided with
14 motorized dampers.

15 **Exceptions:**

16 1. *Outdoor air* ducts at heat or energy recovery ventilation systems are not
17 required to have motorized dampers.

18 2. *Outdoor air* ducts at continuous ventilation systems are not required to have
19 motorized dampers.

20 4. *Outdoor air* ducts in the conditioned space shall be insulated to a minimum of R-4.

21 In heat or energy recovery ventilation systems, ducts upstream of the heat
22 exchanger shall also be insulated to at least R-4.

23 Note: See *Seattle Energy Code* for additional insulation requirements.

<u>90 - 150 cfm</u>	<u>5 inch</u>	<u>6 inch</u>
<u>150 - 250 cfm</u>	<u>6 inch</u>	<u>7 inch</u>
<u>250 - 400 cfm</u>	<u>7 inch</u>	<u>8 inch</u>

1 **403.4.6 Whole house ventilation with exhaust fan systems.** This section establishes
2 minimum requirements for mechanical whole house ventilation systems using exhaust fans.

3 **403.4.6.1 Outdoor air.** Exhaust fan only ventilation systems shall provide *outdoor air* to
4 each occupiable space through one of the following methods:

5 1. *Outdoor air* may be drawn through air inlets installed in exterior walls or windows.

6 The air inlets shall comply with all of the following:

7 1.1. Inlets shall have controllable, secure openings and shall be designed to not
8 compromise the thermal properties of the building envelope.

9 1.2. Inlets shall be accessible to occupants, including compliance with Section
10 1109.13 of the *International Building Code* for designated Accessible units,
11 Type A units and Type B units.

12 1.3. Inlets shall be screened or otherwise protected from entry by insects, leaves,
13 or other material.

14 1.4. Inlets shall provide not less than 4 square inches of net free area of opening
15 for each 10 cfm of *outdoor air* required in Table 403.3.1.1 or Table 403.4.1.

16 1.5. Any inlet or combination of inlets which provide 10 cfm at 10 pascals as
17 determined by the Home Ventilation Institute Air Flow Test Standard (HVI
18 901 (November 1996) are deemed equivalent to 4 square inches of net free
19 area.

20 1.6. Each occupiable space shall have a minimum of one air inlet that has a
21 minimum of 4 square inches of net free area.

1 [W]2. Outdoor air may be drawn in through operable openings to the outdoors. Each
2 habitable space shall be provided with operable openings with an openable area of
3 not less than 4 square inches of net free area of opening for each 10 cfm of outdoor
4 air required by Table 403.3.1.1 or Table 403.4.1. Doors exiting to a corridor, court
5 or public way shall not be used to provide outdoor air. The operable openings shall
6 comply with the following:

7 2.1. Openings shall be controllable, securable, and shall be designed to not
8 compromise the thermal properties of the building envelope.

9 2.2. Openings shall be accessible to occupants, including compliance with Section
10 1109.13 of the International Building Code for designated Accessible units,
11 Type A units and Type B units.

12 2.3. Openings shall be screened or otherwise protected from entry by leaves or
13 other material.

14 3. For interior adjoining spaces without outdoor air openings, one of the following
15 two options shall be used to ventilate the interior adjoining space:

16 3.1. Provide a whole house transfer fan at the interior adjoining space sized to
17 provide a minimum of the ventilation rate required per Section 403.4.5.1. The
18 transfer fan shall circulate air between the interior room or space and the
19 adjacent habitable space. The transfer fan may operate continuously or
20 intermittently using controls per Section 403.4.2.

21 3.2. Provide a permanent opening to the interior adjoining space. Opening shall be
22 unobstructed and shall have an area of not less than 8 percent of the floor area
23 of the interior adjoining space, but not less than 25 square feet.

1 **403.4.6.2 Outside air intake locations.** All *outside air* intake opening types described in
2 Section 403.4.6.1 shall be classified operable openings and shall not be classified as
3 mechanical air intakes. The intake locations shall comply with Section 403.4.3.

4 **403.4.6.3 Whole house exhaust system.** Whole house exhaust system shall be designed
5 and installed to meet all of the applicable criteria below:

6 1. Whole house ventilation exhaust shall be discharged outdoors.

7 2. Exhaust outlets shall comply with Section 501.3.2.

8 3. Exhaust ducts in systems which are designed to operate intermittently shall be
9 equipped with backdraft dampers.

10 4. All exhaust ducts in unconditioned spaces shall be insulated to a minimum of R-

11 4.5. Terminal outlet elements shall have at least the equivalent net free area of the
12 ductwork.

13 5. Terminal outlet elements shall be screened or otherwise protected as required by
14 Section 501.3.2.

15 6. One of the required local exhaust fans for the laundry room or bathroom may be
16 designated as the whole house exhaust fan.

17 7. Exhaust fans in separate dwelling units or sleeping units shall not share common
18 exhaust ducts unless the system is engineered for this operation.

19 8. Where permitted by Chapter 5, whole house exhaust ducts may be combined with
20 other local exhaust ducts. If more than one of the exhaust fans in a dwelling unit or
21 sleeping unit shares a common exhaust duct then each exhaust fan shall be
22 equipped with a backdraft damper to prevent the recirculation of exhaust air from
23 one room to another room via the exhaust ducting system.

1 **403.4.6.4 Whole house exhaust and transfer fans.** Exhaust fan construction and sizing
2 shall meet the following criteria:

3 1. Exhaust and transfer fans shall be tested and rated in accordance with the airflow
4 and sound rating procedures of the Home Ventilating Institute (HVI 915, HVI
5 Loudness Testing and Rating Procedure; HVI 916, Airflow Test Procedure; and
6 HVI 920, Product Performance Certification Procedure).

7 2. Installation of system or equipment shall be carried out in accordance with
8 manufacturers' design requirements and installation instructions.

9 3. Fan airflow rating and duct system shall be designed and installed to deliver at least
10 the outdoor airflow required by Table 403.3.1.1 or Table 403.4.1. The airflows
11 required refer to the delivered airflow of the system as installed and tested using a
12 flow hood, flow grid, or other airflow measurement device.

13 **Exception:** An airflow rating at a pressure of 0.25 in. w.g. may be used, provided
14 the duct sizing meets the prescriptive requirements of Table 403.4.5.2.

15 **403.4.6.5 Fan noise.** Whole house exhaust and transfer fans located 4 feet or less from
16 the interior grille shall have a sone rating of 1.0 or less measured at 0.10 inches water
17 gauge. Manufacturer's noise ratings shall be determined in accordance with HVI 915.
18 Remotely mounted fans shall be acoustically isolated from the structural elements of the
19 building and from attached ductwork using insulated flexible duct or other approved
20 material.

21 **403.4.7 Whole house ventilation integrated with forced-air systems.** This section
22 establishes minimum requirements for mechanical whole house ventilation systems using
23 forced-air system fans.

1 **403.4.7.1 Outdoor air.** Forced-air system fan ventilation systems shall provide *outdoor*
2 *air* through one of the following methods:

3 1. A dedicated *outdoor air* louver and *outdoor air* duct for each dwelling unit or
4 sleeping unit shall supply *outdoor air* to the return side of the forced-air system fan;

5 or

6 2. A central *outdoor air* delivery system that supplies multiple dwelling units or
7 sleeping units shall supply *outdoor air* to the return side of the forced air system
8 fan.

9 **[W]3.** For interior adjoining spaces without *outdoor air* openings, one of the
10 following two options shall be used to ventilate the interior adjoining space:

11 3.1. Provide a whole house transfer fan at the interior adjoining space sized to
12 provide a minimum of the ventilation rate required per Section 403.4.5.1. The
13 transfer fan shall circulate air between the interior room or space and the
14 adjacent habitable space. The transfer fan may operate continuously or
15 intermittently using controls per Section 403.4.2.

16 3.2. Provide a permanent opening to the interior adjoining space. Opening shall be
17 unobstructed and shall have an area of not less than 8 percent of the floor area
18 of the interior adjoining space, but not less than 25 square feet.

19 **403.4.7.2 Whole house forced-air system.** Where *outdoor air* is provided to each
20 habitable dwelling unit or sleeping unit by a forced air system, the *outdoor air* duct shall
21 be connected to the return air stream at a point within 4 feet upstream of the forced-air
22 unit. It shall not be connected directly to the forced-air unit cabinet in order to prevent
23 thermal shock to the heat exchanger. At a minimum, filtration of the *outdoor air* shall be

1 provided at the forced-air unit. The filter shall be accessible for regular maintenance and
2 replacement. The filter shall have a Minimum Efficiency Rating Value (MERV) of at
3 least 6.

4 Each Habitable space in the dwelling or sleeping unit shall be served by a forced air
5 system with *outdoor air* connection.

6 **403.4.8 Whole house ventilation with supply fan systems.** This section establishes
7 minimum requirements for mechanical whole house ventilation systems using supply fan
8 systems.

9 **403.4.8.1 Outdoor air.** Supply fan ventilation systems shall provide *outdoor air* through
10 one of the following methods:

11 1. A dedicated *outdoor air* louver and *outdoor air* duct for each dwelling unit or
12 sleeping unit shall supply *outdoor air* to a supply fan; or

13 2. A central *outdoor air* supply fan system shall distribute unconditioned or
14 conditioned air to multiple dwelling units or sleeping units.

15 [W]3. For interior adjoining spaces without *outdoor air* openings, one of the
16 following two options shall be used to ventilate the interior adjoining space:

17 3.1. Provide a whole house transfer fan at the interior adjoining space sized to
18 provide a minimum of the ventilation rate required per Section 403.4.5.1. The
19 transfer fan shall circulate air between the interior room or space and the
20 adjacent habitable space. The transfer fan may operate continuously or
21 intermittently using controls per Section 403.4.2.

1 3.2. Provide a permanent opening to the interior adjoining space. Opening shall be
2 unobstructed and shall have an area of not less than 8 percent of the floor area
3 of the interior adjoining space, but not less than 25 square feet.

4 **403.4.8.2 Whole house supply system.** Where *outdoor air* is provided to each habitable
5 dwelling unit or sleeping unit by supply fan systems the *outdoor air* shall be filtered.

6 The system filter may be located at the intake device or in line with the fan. The filter
7 shall be accessible for regular maintenance and replacement. The filter shall have a
8 Minimum Efficiency Rating Value (MERV) of at least 6.

9 **403.4.9 Whole house ventilation with heat recovery or energy recovery ventilation**
10 **systems.** This section establishes minimum requirements for mechanical whole house
11 ventilation systems using heat recovery or energy recovery ventilation systems.

12 **403.4.9.1 Outdoor air.** Heat recovery or energy recovery ventilation systems shall
13 provide *outdoor air* through one of the following methods:

14 1. A dedicated *outdoor air* louver and *outdoor air* duct for each dwelling unit or
15 sleeping unit shall supply *outdoor air* to the heat recovery or energy recovery
16 ventilator; or

17 2. A central *outdoor air* heat recovery or energy recovery unit shall distribute
18 conditioned air to multiple dwelling units or sleeping units.

19 [W]3. For interior adjoining spaces without *outdoor air* openings, one of the
20 following two options shall be used to ventilate the interior adjoining space:

21 3.1. Provide a whole house transfer fan at the interior adjoining space sized to
22 provide a minimum of the ventilation rate required per Section 403.4.5.1. The
23 transfer fan shall circulate air between the interior room or space and the

1 adjacent habitable space. The transfer fan may operate continuously or
2 intermittently using controls per Section 403.4.2.

3 3.2. Provide a permanent opening to the interior adjoining space. Opening shall be
4 unobstructed and shall have an area of not less than 8 percent of the floor area
5 of the interior adjoining space, but not less than 25 square feet.

6 **403.4.9.2 Whole house heat recovery ventilator system.** Where *outdoor air* is provided
7 to each habitable dwelling unit or sleeping unit by heat recovery or energy recovery
8 ventilator the *outdoor air* shall be filtered. The filter shall be located on the upstream side
9 of the heat exchanger in both the intake and exhaust airstreams with a Minimum
10 Efficiency Rating Value (MERV) of at least 6. The system filter may be located at the
11 intake device or in line with the fan. The filter shall be accessible for regular maintenance
12 and replacement.

13 Each Habitable space in the dwelling or sleeping unit shall be served by a forced air
14 system with *outdoor air* connection.

15 **403.4.10 Local exhaust ventilation and whole house ventilation alternate performance**
16 **or design requirements.** In lieu of complying with Sections 403.4.4 or 403.4.5 compliance
17 with the section shall be demonstrated through engineering calculations by an engineer
18 licensed to practice in the state of Washington or by performance testing. Documentation of
19 calculations or performance test results shall be submitted to and approved by the code
20 official. Performance testing shall be conducted in accordance with approved test methods.

21 **403.4.11 Alternate systems.** When approved by the *code official*, systems designed in
22 accordance with ASHRAE Standard 62.2 shall be permitted.

1 mechanical system control requirements are contained in the *International Energy Conservation*
2 *Code.*

SECTION 406

VENTILATION OF UNINHABITED SPACES

3
4
5 **406.1 General.** ~~((Uninhabited spaces, such as crawl))~~ Crawl spaces and ~~((A))~~attics~~((;))~~ shall be
6 provided with *natural ventilation* openings as required by the *International Building Code* or
7 shall be provided with a mechanical exhaust and supply air system. The mechanical exhaust rate
8 shall be not less than 0.02 cfm per square foot (0.00001 m³/s • m²) of horizontal area and shall
9 be automatically controlled to operate when the relative humidity in the space served exceeds 60
10 percent.

SECTION 407

AMBULATORY CARE FACILITIES AND GROUP I-2 OCCUPANCIES

11
12
13
14 **[W]407.1 General.** Mechanical ventilation for healthcare facilities licensed by Washington state
15 shall be designed and installed in accordance with this code and the following provisions of the
16 Washington Administrative Code (WAC):

17 1. Mechanical ventilation in ambulatory care facilities shall comply with chapter 246-330

18 WAC.

19 2. Mechanical ventilation for acute care hospitals shall comply with chapter 246-320 WAC.

20 3. Mechanical ventilation for nursing homes shall comply with chapter 388-97 WAC.

21 Mechanical ventilation for unlicensed ambulatory care facilities ~~((and Group I-2 occupancies))~~
22 shall be designed and installed in accordance with this code and ASHRAE 170.

1 Section 7. The following sections of Chapter 5 of the International Mechanical Code,
2 2015 Edition, are amended as follows:

CHAPTER 5

EXHAUST SYSTEMS

SECTION 501

GENERAL

* * *

3
4
5
6 **501.3 Exhaust discharge.** The air removed by every mechanical exhaust system shall be
7 discharged outdoors at a point where it will not cause a public nuisance and not less than the
8 distances specified in Section 501.3.1. The air shall be discharged to a location from which it
9 cannot again be readily drawn in by a ventilating system. Air shall not be exhausted into an attic,
10 crawl space, or be directed onto walkways.

Exceptions:

- 11
12 1. Whole-house ventilation-type attic fans shall be permitted to discharge into the attic
13 space of *dwelling units* having private attics.
- 14 2. Commercial cooking recirculating systems are not required to discharge outdoors if the
15 kitchen area has an exhaust system that is vented to the outside. Ventilation shall be
16 provided in accordance with Chapter 4.
- 17 3. Where installed in accordance with the manufacturer's instructions and where
18 mechanical or *natural ventilation* is otherwise provided in accordance with Chapter 4,
19 *listed* and *labeled* domestic ductless range hoods shall not be required to discharge to
20 the outdoors.

1 **501.3.1 Location of exhaust outlets.** The termination point of exhaust outlets and ducts
2 discharging to the outdoors shall be located with the following minimum distances:

3 1. For ducts conveying explosive or flammable vapors, fumes or dusts: 30 feet (9144
4 mm) from property lines; 10 feet (3048 mm) from operable openings into buildings; 6
5 feet (1829 mm) from exterior walls and roofs; 30 feet (9144 mm) from combustible
6 walls and operable openings into buildings which are in the direction of the exhaust
7 discharge; 10 feet (3048 mm) above adjoining grade.

8 **Interpretation:** Item 1 includes carpentry shop exhaust, industrial chemical lab, paint shop
9 and sandblasting exhaust systems. For clearances and encroachments in the public right of
10 way, see Section 304.11.

11 2. For other product-conveying outlets: 10 feet (3048 mm) from the property lines; 3 feet
12 (914 mm) from exterior walls and roofs; 10 feet (3048 mm) from operable openings
13 into buildings; 10 feet (3048 mm) above adjoining grade.

14 **Interpretation:** Item 2 includes central vacuum systems, dry cleaner, photo lab, school
15 chemical lab, nail salon, dryer exhaust over 250° source capture system exhaust and
16 combustion engine exhaust.

17 **[W]**3. For all *environmental air* exhaust other than enclosed parking garage and
18 transformer vault exhaust: 3 feet (914 mm) from property lines; 3 feet (914 mm) from
19 operable openings into buildings for all occupancies other than Group U, and 10 feet
20 (3048 mm) from mechanical air intakes. Such exhaust shall not be considered
21 hazardous or noxious.

1 **Exceptions:**

2 1. The separation between an air intake and exhaust outlet on a single listed
3 package HVAC unit.

4 2. Exhaust from environmental air systems other than garages may be
5 discharged into an open parking garage.

6 3. Except for Group I occupancies, where ventilation system design
7 circumstances require building HVAC air to be relieved, such as during
8 economizer operation, such air may be relieved into an open or enclosed
9 parking garage within the same building.

10 4. Exhaust outlets serving structures in flood hazard areas shall be installed at
11 or above the elevation required by Section 1612 of the *International*
12 *Building Code* for utilities and attendant equipment.

13 5. For enclosed parking garage, loading dock, and motor vehicle repair garage
14 exhaust outlets: Exhaust ventilation openings and duct terminations shall be
15 located not less than 10 feet (3048 mm) from property lines, operable
16 openings into buildings, and mechanical air intakes; and 10 feet (3048 mm)
17 above adjoining finished walking surfaces other than alleys. Exhaust outlets
18 extending to the roof shall extend 3 feet (914 mm) above the roof surface.

19 [W] 6. For elevator machinery rooms in enclosed or open parking garages:
20 Exhaust outlets may discharge air directly into the parking garage.

21 7. For transformer vault exhaust systems: Exhaust ventilation openings and
22 duct terminations shall be located not less than 10 feet (3048 mm) from fire
23 escapes, required means of egress at the exterior of the building, elements

1 of the exit discharge, combustibile exterior wall coverings, unprotected
2 openings, operable openings and property lines other than a public way.

3 Exhaust outlets shall be located on the exterior of the building. See *Seattle*
4 *Building Code* Section 428 for additional requirements.

5 ((5)) 8. For specific systems see the following sections:

6 ((5-1)) 8.1. Clothes dryer exhaust, Section 504.4.

7 ((5-2)) 8.2. Kitchen hoods and other kitchen exhaust *equipment*, Sections
8 506.3.13, 506.4 and 506.5.

9 ((5-3)) 8.3. Dust stock and refuse conveying systems, Section 511.2.

10 ((5-4)) 8.4. Subslab soil exhaust systems, Section 512.4.

11 ((5-5)) 8.5. Smoke control systems, Section 513.10.3.

12 ((5-6)) 8.6. Refrigerant discharge, Section 1105.7.

13 ((5-7)) 8.7. Machinery room discharge, Section 1105.6.1.

14 **Note:** Seattle Land Use Code (Municipal Code Title 23) requires that the venting of odors,
15 vapors, smoke, cinders, dust, gas and fumes shall be at least 10 feet (3048 mm) above finished
16 sidewalk grade, and directed away as much as possible from residential uses within 50 feet (15
17 240 mm) of the vent in some locations.

18 * * *

19 **501.4 Pressure equalization.** Mechanical exhaust systems shall be sized to remove the quantity
20 of air required by this chapter to be exhausted. The system shall operate when air is required to
21 be exhausted. Where mechanical exhaust is required in a room or space (~~in other than~~
22 ~~occupancies in R-3 and dwelling units in R-2~~)), such space shall be maintained with a neutral or
23 negative pressure. If a greater quantity of air is supplied by a mechanical ventilating supply

1 system than is removed by a mechanical exhaust for a room, adequate means shall be provided
2 for the natural or mechanical exhaust of the excess air supplied. If only a mechanical exhaust
3 system is installed for a room or if a greater quantity of air is removed by a mechanical exhaust
4 system than is supplied by a mechanical ventilating supply system for a room, adequate *makeup*
5 *air* shall be provided to satisfy the deficiency.

6 **Exception:** R-3 occupancies and dwelling units in R-2 occupancies are excluded from the
7 pressure equalization requirement unless required by Section 504.5 or Section 505.2.

8 * * *

9 SECTION 502

10 REQUIRED SYSTEMS

11 **502.1 General.** An exhaust system shall be provided, maintained and operated as specifically
12 required by this section and for all occupied areas where machines, vats, tanks, furnaces, forges,
13 salamanders and other *appliances, equipment* and processes in such areas produce or throw off
14 dust or particles sufficiently light to float in the air, or which emit heat, odors, fumes, spray, gas
15 or smoke, in such quantities so as to be irritating or injurious to health or safety. These exhaust
16 systems are considered product-conveying systems.

17 **502.1.1 Exhaust inlet location.** The inlet to an exhaust system shall be located in the area of
18 heaviest concentration of contaminants.

19 * * *

20 **[F] 502.4 Stationary storage battery systems.** Stationary storage battery systems having a
21 liquid capacity of more than 50 gallons, as regulated by Section 608 of the *International Fire*
22 *Code*, shall be provided with ventilation in accordance with this chapter and Sections 502.4.1
23 ((~~502.4.1~~)) and 502.4.2.

1 vehicles are operated shall be provided with a *source capture system* that connects directly to the
2 motor vehicle exhaust systems. When the source capture system extends more than 10 feet from
3 the tailpipe connection to the outdoors, the system shall exhaust at a rate of 600 cfm for heavy-
4 duty diesel vehicles and at a rate of 300 cfm for all other vehicles. Such system shall be
5 engineered by a registered design professional (~~or shall be factory built equipment designed and~~
6 ~~sized for the purpose~~)).

7 **Exceptions:**

- 8 1. This section shall not apply where the motor vehicles being operated or repaired are
9 electrically owered.
- 10 2. This section shall not apply to one- and two-family dwellings.
- 11 3. This section shall not apply to motor vehicle service areas where engines are operated
12 inside the building only for the duration necessary to move the motor vehicles in and
13 out of the building.

14 **[F] 502.15 Repair garages and other spaces.** Where Class I liquids or LP-gas are stored or used
15 within a building having a basement or pit wherein flammable vapors could accumulate, the
16 basement or pit shall be provided with ventilation designed to prevent the accumulation of
17 flammable vapors therein.

18 * * *

19 **502.18 Specific rooms.** Specific rooms, including bathrooms, locker rooms, smoking lounges
20 and toilet rooms, shall be exhausted in accordance with the ventilation requirements of Chapter
21 4.

22 **Informative Note:** RCW 70.160.030 states: “No person may smoke in a public place or in any
23 place of employment.” A public place is defined in RCW 70.160.020 in part as: “...A public

1 place does not include a private residence unless the private residence is used to provide
2 licensed child care, foster care, adult care, or other similar social service care on the premises.
3 This chapter is not intended to restrict smoking in private facilities which are occasionally open
4 to the public except upon the occasions when the facility is open to the public.”

5 * * *

6 SECTION 504

7 CLOTHES DRYER EXHAUST

8 * * *

9 **504.2.1 Protection required.** Protective shield plates shall be placed where nails or screws
10 from finish or other work are likely to penetrate the clothes dryer exhaust duct. Shield plates
11 shall be placed on the finished face of all framing members where there is less than 1-1/4
12 inches (32 mm) between the duct and the finished face of the framing member. Protective
13 shield plates shall be constructed of steel, have a thickness of 0.062 inch (1.6 mm) and
14 extend a minimum of 2 inches (51 mm) above sole plates and below top plates.

15 **504.3 Cleanout.** Each vertical riser shall be provided with a means for cleanout.

16 **[W]504.4 Exhaust installation.** Dryer exhaust ducts for clothes dryers shall terminate on the
17 outside of the building and shall be equipped with a backdraft damper located where the duct
18 terminates. Dryer exhaust ducts may terminate at exterior wall louvers with openings spaced not
19 less than 1/2" in any direction.

20 Screens shall not be installed at the duct termination. Ducts shall not be connected or
21 installed with sheet metal screws or other fasteners that will obstruct the exhaust flow. Clothes
22 dryer exhaust ducts shall not be connected to a vent connector, vent or *chimney*. Clothes dryer
23 exhaust ducts shall not extend into or through ducts or plenums.

1 2158A. Transition ducts shall be not greater than 8 feet (2438 mm) in length and shall not be
2 concealed within construction.

3 ~~((504.8.4))~~ **504.7.4 Duct length.** The maximum allowable exhaust duct length shall be
4 determined by one of the methods specified in Sections ~~((504.8.4.1 through 504.8.4.3))~~
5 504.7.4.1 and 504.7.4.2.

6 **[W]** ~~((504.8.4.1 Specified length. The maximum length of the exhaust duct shall be 35~~
7 ~~feet (10 668 mm) from the connection to the transition duct from the dryer to the outlet~~
8 ~~terminal. Where fittings are used, the maximum length of the exhaust duct shall be~~
9 ~~reduced in accordance with Table 504.8.4.1.))~~

10 **TABLE ~~((504.8.4.1))~~ 504.7.4.1**

DRYER EXHAUST DUCT FITTING EQUIVALENT LENGTH

DRYER EXHAUST DUCT FITTING TYPE	EQUIVALENT LENGTH
4" radius mitered 45-degree elbow	2 feet 6 inches
4" radius mitered 90-degree elbow	5 feet
6" radius smooth 45-degree elbow	1 foot
6" radius smooth 90-degree elbow	1 foot 9 inches
8" radius smooth 45-degree elbow	1 foot
8" radius smooth 90-degree elbow	1 foot 7 inches
10" radius smooth 45-degree elbow	9 inches
10" radius smooth 90-degree elbow	1 foot 6 inches

For SI: 1 inch = 25.4 mm, 1 foot = 304.8 mm, 1 degree = 0.0175 rad.

11 ~~((504.8.4.2))~~ **504.7.4.1 Manufacturer's instructions.** The maximum length of the exhaust duct
12 shall be determined by the dryer manufacturer's installation instructions. The code official shall
13 be provided with a copy of the installation instructions for the make and model of the dryer.

14 Where the exhaust duct is to be concealed, the installation instructions shall be
15 provided to the code official prior to the concealment inspection. In the absence of fitting
16 equivalent length calculations from the clothes dryer manufacturer, Table ~~((504.8.4.1))~~
17 5047.4.1 shall be used.

1 ~~((504.8.4.3))~~ **504.7.4.2 Dryer exhaust duct power ventilator length.** The maximum
2 length of the exhaust duct shall be determined by the dryer exhaust duct power ventilator
3 manufacturer's installation instructions.

4 ~~((504.8.5))~~ **504.7.5 Length identification.** Where the exhaust duct equivalent length exceeds
5 35 feet (10 668 mm), the equivalent length of the exhaust duct shall be identified on a
6 permanent label or tag. The label or tag shall be located within 6 feet (1829 mm) of the
7 exhaust duct connection.

8 ~~((504.8.6))~~ **504.7.6 Exhaust duct required.** Where space for a clothes dryer is provided, an
9 exhaust duct system shall be installed. Where the clothes dryer is not installed at the time of
10 occupancy, the exhaust duct shall be capped at the location of the future dryer.

11 **Exception:** Where a *listed* condensing clothes dryer is installed prior to occupancy of
12 structure.

13 ~~((504.9))~~ **504.8 Commercial clothes dryers.** The installation of dryer exhaust ducts serving
14 commercial clothes dryers shall comply with the *appliance* manufacturer's installation
15 instructions. Exhaust fan motors installed in exhaust systems shall be located outside of the
16 airstream. In multiple installations, the fan shall operate continuously or be interlocked to operate
17 when any individual unit is operating. Ducts shall have a minimum *clearance* of 6 inches (152
18 mm) to combustible materials. Clothes dryer transition ducts used to connect the *appliance* to the
19 exhaust duct system shall be limited to single lengths not to exceed 8 feet (2438 mm) in length
20 and shall be *listed* and *labeled* for the application. Transition ducts shall not be concealed within
21 construction.

22 ~~((504.10))~~ **504.9 Common exhaust systems for clothes dryers located in multistory**
23 **structures.** Where a common multistory duct system is designed and installed to convey exhaust

1 from multiple clothes dryers, the construction of the system shall be in accordance with all of the
2 following:

3 1. The shaft in which the duct is installed shall be constructed and fire-resistance rated as
4 required by the *International Building Code*.

5 2. Dampers shall be prohibited in the exhaust duct. Penetrations of the shaft and ductwork
6 shall be protected in accordance with Section 607.5.5, Exception 2.

7 3. Rigid metal ductwork shall be installed within the shaft to convey the exhaust. The
8 ductwork shall be constructed of sheet steel having a minimum thickness of 0.0187 inch
9 (0.4712 mm) (No. 26 gage) and in accordance with *SMACNA Duct Construction*
10 *Standards*.

11 4. The ductwork within the shaft shall be designed and installed without offsets.

12 5. The exhaust fan motor design shall be in accordance with Section 503.2.

13 6. The exhaust fan motor shall be located outside of the airstream.

14 7. The exhaust fan shall run continuously, and shall be connected to a legally required
15 standby power source.

16 8. Exhaust fan operation shall be monitored in an *approved* location and shall initiate an
17 audible or visual signal when the fan is not in operation.

18 **[W]**9. Makeup air shall be provided for the exhaust system to maintain the minimum flow for
19 the exhaust fan when the dryers are not operating. Additionally, makeup air shall be
20 provided when required by Section 504.5.

21 10. A cleanout opening shall be located at the base of the shaft to provide *access* to the duct
22 to allow for cleaning and inspection. The finished opening shall be not less than 12 inches
23 by 12 inches (305 mm by 305 mm).

1 11. Screens shall not be installed at the termination.

2 12. The common multistory duct system shall serve only clothes dryers and shall be
3 independent of other exhaust systems.

4 **SECTION 505**

5 **DOMESTIC KITCHEN EXHAUST EQUIPMENT**

6 **[W]505.1 Domestic systems.** Where domestic range hoods and domestic appliances equipped
7 with downdraft exhaust are provided, such hoods and appliances shall discharge to the outdoors
8 through sheet metal ducts constructed of galvanized steel, stainless steel, aluminum or copper.
9 Such ducts shall have smooth inner walls, shall be air tight, shall be equipped with a backdraft
10 damper, and shall be independent of all other exhaust systems.

11 Domestic kitchen exhaust ducts may terminate with other domestic dryer exhaust and
12 residential local exhaust ducts at a common location where each duct has an independent back-
13 draft damper.

14 Listed and labeled exhaust booster fans shall be permitted when installed in accordance with
15 the manufacturer's installation instructions.

16 **Exceptions:**

- 17 1. In other than Group I-1 and I-2, where installed in accordance with the manufacturer's
18 instructions and where mechanical (~~or natural~~) ventilation is otherwise provided in
19 accordance with Chapter 4, listed and labeled ductless range hoods shall not be
20 required to discharge to the outdoors.

1 **Interpretation:** Chapter 4 requires separate local exhaust systems in kitchens, including
2 where ductless range hoods (also known as recirculating hoods) are used. Ductless range
3 hoods are permitted in dwelling units where exhaust systems in the kitchen meet the
4 requirements for local exhaust. In no case is natural ventilation, such as an operable window,
5 allowed to substitute for the required kitchen local exhaust system.

6 2. Ducts for domestic kitchen cooking appliances equipped with downdraft exhaust
7 systems shall be permitted to be constructed of Schedule 40 PVC pipe and fittings
8 provided that the installation complies with all of the following:

9 2.1. The duct shall be installed under a concrete slab poured on grade.

10 2.2. The underfloor trench in which the duct is installed shall be completely
11 backfilled with sand or gravel.

12 2.3. The PVC duct shall extend not more than 1 inch (25 mm) above the indoor
13 concrete floor surface.

14 2.4. The PVC duct shall extend not more than 1 inch (25 mm) above grade outside of
15 the building.

16 2.5. The PVC ducts shall be solvent cemented.

17 * * *

18 SECTION 506

19 COMMERCIAL KITCHEN HOOD VENTILATION SYSTEM DUCTS

20 AND EXHAUST EQUIPMENT

21 * * *

22 **506.3.2.4 Vibration isolation.** A vibration isolation connector for connecting a duct to a
23 fan shall consist of noncombustible packing in a metal sleeve joint of *approved* design or

1 shall be a coated-fabric flexible duct connector (~~((listed and labeled for the application))~~)
2 rated for continuous duty at temperature of not less than 1500° F (816° C). Vibration
3 isolation connectors shall be installed only at the connection of a duct to a fan inlet or
4 outlet.

5 * * *

6 **506.3.5 Separation of grease duct system.** A separate grease duct system shall be provided
7 for each Type I hood. (~~((A separate grease duct system is not required))~~) Multiple Type I
8 hoods are permitted to be combined where all of the following conditions are met:

- 9 1. All interconnected hoods are located within the same story.
- 10 2. All interconnected hoods are located within the same room or in adjoining rooms.
- 11 3. Interconnecting ducts do not penetrate assemblies required to be fire-resistance rated.
- 12 4. The grease duct system does not serve solid-fueled appliances.

13 * * *

14 **[W]506.3.9 Grease duct cleanout location, spacing and installation.**

15 **506.3.9.1 Grease duct horizontal cleanouts.** Cleanouts serving horizontal sections of
16 grease ducts shall:

- 17 1. Be spaced not more than 20 feet (6096 mm) apart.
- 18 2. Be located not more than 10 feet (3048 mm) from changes in direction that are
19 greater than 45 degrees (0.79 rad).
- 20 3. Be located on the bottom only where other locations are not available and shall be
21 provided with internal damming of the opening such that grease will flow past the
22 opening without pooling. Bottom cleanouts and openings shall be approved for the
23 application and installed liquid-tight.

1 Chapter 6. A duct serving a Type II hood that penetrates a fire-resistance-rated ceiling, floor
2 or wall shall be in a rated enclosure from the point of penetration to the outlet with a rating
3 equal to the fire-resistance rating of the assembly being penetrated. Ducts subject to positive
4 pressure and ducts conveying moisture-laden or waste-heat-laden air shall be constructed,
5 joined and sealed in an *approved* manner.

6 **506.4.2 Type II terminations.** Exhaust outlets serving Type II hoods shall terminate in
7 accordance with the hood manufacturer's installation instructions and shall comply with all
8 of the following:

- 9 1. Exhaust outlets shall terminate not less than 3 feet (914 mm) in any direction from
10 openings into the building.
- 11 2. Outlets shall terminate not less than 10 feet (3048 mm) from property lines or
12 buildings on the same lot.
- 13 3. Outlets shall terminate not less than 10 feet (3048 mm) above grade.
- 14 4. Outlets that terminate above a roof shall terminate not less than 30 inches (762 mm)
15 above the roof surface.
- 16 5. Vertical ((Θ))outlets on roofs shall terminate not less than 30 inches (762 mm) from
17 exterior vertical walls
- 18 6. Outlets shall be protected against local weather conditions.
- 19 7. Outlets shall not be directed onto walkways.
- 20 8. Outlets shall meet the provisions for exterior wall opening protectives in accordance
21 with the *International Building Code*.

22 * * *

purpose of determining the floor area required to be ventilated, each individual *appliance* shall be considered as occupying not less than 100 square feet (9.3 m2).

3. Where cooking appliances are equipped with integral down-draft exhaust systems and such appliances and exhaust systems are listed and labeled for the application in accordance with NFPA 96, a hood shall not be required at or above them.

* * *

[W] Table 507.2.1 Type of Hood Required for Commercial Cooking Appliances

<u>TYPE OF APPLIANCE¹</u>	<u>TYPE OF HOOD REQUIRED²</u>		
	<u>TYPE I³</u>	<u>TYPE II</u>	<u>NONE⁶</u>
<u>Baking oven</u>	<u>Solid fuel</u>	<u>> 6 kW</u>	<u>≤ 6 kW</u>
<u>Charbroiler</u>	<u>All sizes</u>		
<u>Coffee maker</u>		<u>> 6 kW</u>	<u>≤ 6 kW</u>
<u>Coffee roaster⁴</u>		<u>All sizes</u>	
<u>Convection ovens (electric)</u>		<u>> 6 kW</u>	<u>< 6 kW</u>
<u>Deep-fat fryer</u>	<u>All sizes</u>		
<u>Dishwasher</u>		<u>> 140°F</u>	<u>≤ 140°F</u>
<u>Grill</u>	<u>All sizes</u>		
<u>Hot dog display heater</u>		<u>> 6 kW</u>	<u>≤ 6 kW</u>
<u>Microwave oven</u>			<u>All sizes</u>
<u>Pastry oven</u>		<u>> 6 kW</u>	<u>≤ 6 kW</u>
<u>Pizza oven</u>	<u>Solid fuel</u>	<u>> 6 kW</u>	<u>≤ 6 kW</u>
<u>Popcorn maker</u>		<u>> 6 kW</u>	<u>≤ 6 kW</u>
<u>Roasting oven⁵</u>	<u>> 6 kW</u>	<u>≤ 6 kW</u>	
<u>Roll warmer</u>		<u>> 6 kW</u>	<u>≤ 6 kW</u>
<u>Solid-fuel burning appliances</u>	<u>All sizes & all food products</u>		
<u>Soup warmer, soup preparation cooking unit</u>		<u>> 6 kW</u>	<u>≤ 6 kW</u>
<u>Steam reconstitution device</u>		<u>> 6 kW</u>	<u>≤ 6 kW</u>
<u>Steam table</u>		<u>> 6 kW</u>	<u>≤ 6 kW</u>
<u>Steamer</u>		<u>> 6 kW</u>	<u>≤ 6 kW</u>
<u>Toaster</u>		<u>> 6 kW</u>	<u>≤ 6 kW</u>
<u>Warming oven</u>		<u>> 6 kW</u>	<u>≤ 6 kW</u>
¹ The code official shall determine hood requirements for appliances not listed in the table.			
² Section 507.2 describes Type I and Type II kitchen hoods.			
³ The definition of extra-heavy-duty cooking appliance includes all appliances utilizing solid fuel.			
⁴ Puget Sound pollution control requires an after-burner for particulates.			

⁵ Roasting ovens are used to cook raw or partially cooked food.

⁶ Where no hood is required, general kitchen exhaust shall be required per Section 507.3

Table 507.1.2 Type of Hood Required for Domestic Cooking Appliances ^{1,2}		
<u>Type of Space³</u>	<u>Type of cooking</u>	<u>Type of hood</u>
<u>Church</u>	1) <u>Boiling, steaming and warming precooked food</u>	<u>Type II</u>
	2) <u>Roasting, pan frying and deep frying</u>	<u>Type I</u>
<u>Community or party room in apartment and condominium</u>	1) <u>Boiling, steaming and warming precooked food</u>	<u>Residential hood⁴ or Type II ⁵</u>
	2) <u>Roasting, pan frying and deep frying</u>	<u>Type I</u>
<u>Day care</u>	1) <u>Boiling, steaming and warming precooked food</u>	<u>Residential hood⁴ or Type II ⁵</u>
	2) <u>Roasting, pan frying and deep frying</u>	<u>Type I</u>
<u>Dormitory, boarding home, nursing home</u>	1) <u>Boiling, steaming and warming precooked food</u>	<u>Type II</u>
	2) <u>Roasting, pan frying and deep frying</u>	<u>Type I</u>
<u>Office lunch room</u>	1) <u>Boiling, steaming and warming precooked food</u>	<u>Residential hood⁴ or Type II ⁵</u>
	2) <u>Roasting, pan frying and deep frying</u>	<u>Type I</u>

¹ Commercial cooking appliances shall comply with Section 507.2

² Requirements in this table apply to electric or gas fuel appliances only. Solid fuel appliances or charbroilers require Type I hoods.

³ The code official shall determine hood requirements for other types of spaces.

⁴ Residential hood shall vent to outside.

⁵ Type II hood required when more than one appliance over 6kW total is used.

1 **[W]507.1.2 Domestic cooking appliances used for commercial purposes.** Domestic
 2 cooking appliances utilized for commercial purposes shall be provided with Type I, ((~~or~~))
 3 Type II or residential hoods ((as required for the type of appliances and processes)) in
 4 accordance with Sections 507.2 and 507.3 and Table 507.1.2.
 5 Domestic cooking appliances utilized for domestic purposes shall comply with Section 505.

6 * * *

1 **507.2 Type I hoods.** Type I hoods shall be installed where cooking *appliances* produce grease or
2 smoke as a result of the cooking process. Type I hoods shall be installed over *medium-duty*,
3 *heavy-duty* and *extra-heavy-duty cooking appliances*.

4 **Exception:**

5 1. A Type I hood shall not be required for an electric cooking appliance where an
6 approved testing agency provides documentation that the appliance effluent contains 5
7 mg/m³ or less of grease when tested at an exhaust flow rate of 500 cfm (0.236 m³/s) in
8 accordance with UL 710B.

9 [W]2. A Type I hood shall not be required in an R-2 an occupancy with not more than 16
10 residents.

11 * * *

12 **507.2.6 Clearances for Type I hood.** A Type I hood shall be installed with a *clearance* to
13 combustibles of not less than 18 inches (457 mm).

14 **Exception:** *Clearance* shall not be required from gypsum wallboard or 1/2-inch (12.7
15 mm) or thicker cementitious wallboard attached to noncombustible structures provided
16 that a smooth, cleanable, nonabsorbent and noncombustible material is installed between
17 the hood and the gypsum or cementitious wallboard over an area extending not less than
18 18 inches (457 mm) in all directions from the hood.

19 **Interpretation:** Gypsum wallboard installed on a combustible substrate or on wood studs
20 does not cause the wall to be considered a noncombustible assembly, and the 18 inch
21 minimum clearance still applies. The classification of combustible and noncombustible
22 materials is not changed by the use of fire-retardant-treated wood products or fire rated (Type
23 “X”) gypsum wallboard.

1 2. A vapor, gas, fume, mist or dust with a health-hazard rating of 4 is present in any
2 concentration.

3 3. A vapor, gas, fume, mist or dust with a health-hazard rating of 1, 2 or 3 is present in
4 concentrations exceeding 1 percent of the median lethal concentration of the substance for
5 acute inhalation toxicity.

6 ~~((Exception: Laboratories, as defined in Section 510.1, except where the concentrations
7 listed in Item 1 are
8 exceeded or a vapor, gas, fume, mist or dust with a health hazard rating of 1, 2, 3 or 4 is
9 present in concentrations exceeding 1 percent of the median lethal concentration of the
10 substance for acute inhalation toxicity.))~~

11 In lieu of complying with this section, research and educational laboratories are permitted to
12 comply with rules adopted by the Director for laboratory exhaust systems for hazardous
13 materials.

14 Note: See Director's Rule 30-2005 for provisions on ventilation systems in research and
15 educational laboratories.

16 * * *

17 **510.2.3 Model shops and other intermittent use facilities.** Equipment or machinery located
18 inside buildings that emit dust but are used on an intermittent basis, such as in model shops,
19 research and development facilities, hobby, and other non-production uses, shall be provided
20 with a local, point of use dust collection system. The dust collector is permitted to be a
21 portable type with high efficiency filters to allow exhaust air to be discharged back into the
22 space. Such collectors are not required to be provided with an approved explosion-control

1 system. Such systems shall be limited to an aggregate airflow of no more than 1,500 cfm per
2 room.

3 * * *

4 **510.8 Suppression required.**

5 **510.8.1 Ducts.** Ducts shall be protected with an *approved* automatic fire suppression system
6 installed in accordance with the *International Building Code*.

7 **Exceptions:**

- 8 1. An approved automatic fire suppression system shall not be required in ducts
9 conveying materials, fumes, mists and vapors that are nonflammable and
10 noncombustible under all conditions and at any concentrations.
- 11 2. Automatic fire suppression systems shall not be required in metallic and
12 noncombustible, nonmetallic exhaust ducts in semiconductor fabrication facilities.
- 13 3. An *approved* automatic fire suppression system shall not be required in ducts
14 where the largest cross-sectional diameter of the duct is less than 10 inches (254
15 mm).
- 16 4. For laboratories, as defined in Section 510.1, automatic fire protection systems
17 shall not be required for metallic ducts that serve (~~(in)~~) laboratory hoods or exhaust
18 systems
- 19 5. An *approved* automatic fire suppression system is not required in metallic ducts
20 serving fume hoods if all fume hoods served by the duct are equipped with an
21 approved fire suppression system.

22 **510.8.2 Fume hoods.** Approved automatic fire suppression shall be installed in fume hoods
23 within which operations are conducted involving hazardous materials that have the potential

1 to create a flammable vapor, gas, fume, mist, or dust in concentrations exceeding 25 percent
2 of the lower flammability limit of the substance or mixture for the expected room
3 temperature in the absence of the fume hood and under normal operating conditions.

4 * * *

5 SECTION 511

6 DUST, STOCK AND REFUSE CONVEYING SYSTEMS

7 * * *

8 **511.1.1 Collectors and separators.** Collectors and separators involving such systems as
9 centrifugal separators, bag filter systems and similar devices, and associated supports shall be
10 constructed of noncombustible materials and shall be located on the exterior of the building
11 or structure.

12 A collector or separator shall not be located nearer than 10 feet (3048 mm) to combustible
13 construction or to an unprotected wall or floor opening, unless the collector is provided with
14 a metal vent pipe that extends above the highest part of any roof with a distance of 30 feet
15 (9144 mm).

16 **Exceptions:**

- 17 1. Collectors such as “Point of Use” collectors, close extraction weld fume collectors,
18 spray finishing booths, stationary grinding tables, sanding booths, and integrated or
19 machine-mounted collectors shall be permitted to be installed indoors provided the
20 installation is in accordance with the *International Fire Code* and NFPA 70.
- 21 2. Collectors in independent exhaust systems handling combustible dusts shall be
22 permitted to be installed indoors provided that such collectors are installed in

1 compliance with the *International Fire Code* and ((~~NFPA 70~~)) the Seattle
2 *Electrical Code*.

3 * * *

4 SECTION 512

5 SUBSLAB SOIL EXHAUST SYSTEMS

6 **512.1 General.** Where a subslab soil exhaust system is provided, the duct shall conform to the
7 requirements of this section.

8 **512.2 Materials.** Subslab soil exhaust system duct material shall be air duct material *listed* and
9 *labeled* to the requirements of UL 181 for Class 0 air ducts, or any of the following piping
10 materials that comply with the ((~~International~~)) *Uniform Plumbing Code* as building sanitary
11 drainage and vent pipe: cast iron; galvanized steel; brass or copper pipe; copper tube of a weight
12 not less than that of copper drainage tube, Type DWV; and plastic piping.

13 SECTION 513

14 SMOKE CONTROL SYSTEMS

15 * * *

16 **[F] 513.3 Special inspection and test requirements.** In addition to the ordinary inspection and
17 test requirements that buildings, structures and parts thereof are required to undergo, smoke
18 control systems subject to the provisions of Section 909 of the *International Building Code* shall
19 undergo special inspections and tests sufficient to verify the proper commissioning of the smoke
20 control design in its final installed condition. The design submission accompanying the
21 *construction documents* shall clearly detail procedures and methods to be used and the items
22 subject to such inspections and tests. Such commissioning shall be in accordance with generally
23 accepted engineering practice and, where possible, based on published standards for the

1 particular testing involved. The special inspections and tests required by this section shall be
2 conducted under the same terms as found in Section 1704 of the *International Building Code*.

3 **Note:** See Seattle Fire Department (SFD) Administrative Rule 9.02.14.

4 * * *

5 **[F] 513.5 Smoke barrier construction.** Smoke barriers required for ~~((passive))~~ engineered
6 smoke control and a smoke control system using the pressurization method shall comply with
7 Section 709 of the *International Building Code*. The maximum allowable leakage area shall be
8 the aggregate area calculated using the following leakage area ratios:

- 9 1. Walls: $A/A_w = 0.00100$
10 2. Interior exit stairways and ramps and exit passageways: $A/A_w = 0.00035$
11 3. Enclosed exit access stairways and ramps and all other shafts: $A/A_w = 0.00150$
12 4. Floors and roofs: $A/AF = 0.00050$

13 where:

14 A = Total leakage area, square feet (m²).

15 AF = Unit floor or roof area of barrier, square feet (m²).

16 A_w = Unit wall area of barrier, square feet (m²).

17 The leakage area ratios shown do not include openings created by gaps around doors and
18 operable windows. The total leakage area of the smoke barrier shall be determined in accordance
19 with Section 513.5.1 and tested in accordance with Section 513.5.2.

20 * * *

21 **[F] 513.11** ~~((Standby))~~ **Emergency power.** The smoke control system shall be supplied with
22 ~~((standby))~~ emergency power in accordance with Section 2702 of the *International Building*
23 *Code*.

1 [F] **513.11.1 Equipment room.** The ~~((standby))~~ emergency power source and its transfer
2 switches shall be in a room separate from the normal power transformers and switch gear and
3 ventilated directly to and from the exterior. The room shall be enclosed with not less than 1-
4 hour fire-resistance-rated fire barriers constructed in accordance with Section 707 of the
5 *International Building Code* or horizontal assemblies constructed in accordance with Section
6 711 of the *International Building Code*, or both.

7 * * *

8 [F] ~~((513.11.2))~~ **513.11.3 Wiring.** In addition to meeting requirements of the *Seattle Electrical*
9 *Code*, all wiring regardless of voltage, shall have fire-resistance-rated protection of at least
10 two hours or as required in rules promulgated by the *code official*.

11 **Exception:** Subject to the approval of the *code official*, fire-resistance-rating is not
12 required for wiring located in a parking garage.

13 * * *

14 [F] **513.12.2 Wiring.** ~~((In addition to meeting the requirements of NFPA 70, all wiring,~~
15 ~~regardless of voltage, shall be fully enclosed within continuous raceways.)) See Section~~
16 513.11.

17 * * *

18 [F] **513.12.4 Automatic control.** Where complete automatic control is required or used, the
19 automatic control sequences shall be initiated from an appropriately zoned automatic
20 sprinkler system complying with Section 903.3.1.1 of the *International Fire Code*, from
21 manual controls that are readily accessible to the fire department, and any smoke detectors in
22 the building ~~((required by engineering analysis)).~~

23 * * *

1 **[W]SECTION 515**

2 **WASTE OR LINEN CHUTE VENTING**

3 **515.1 General.** Waste or linen chutes shall be gravity vented per NFPA 82.

4 **Exception:** Waste or linen chutes may be mechanically ventilated by an exhaust fan. The
5 exhaust fan shall be located outside the building at the top of the chute.

6 Section 8. The following sections of Chapter 6 of the International Mechanical Code,
7 2015 Edition, are amended as follows:

8 **CHAPTER 6**

9 **DUCT SYSTEMS**

10 **SECTION 601**

11 **GENERAL**

12 * * *

13 **[BF] 601.2 Air movement in egress elements.** Corridors shall not serve as supply, return,
14 exhaust, relief or *ventilation air* ducts.

15 **Exceptions:**

- 16 1. Use of a corridor as a source of *makeup air* for exhaust systems in rooms that open directly
17 onto such corridors, including toilet rooms, bathrooms, dressing rooms, (~~smoking~~
18 ~~lounges~~) and janitor closets, shall be permitted, provided that each such corridor is
19 directly supplied with (~~outdoor~~) air at a rate greater than the rate of *makeup air* taken
20 from the corridor.
21 2. Where located within a *dwelling unit*, the use of corridors for conveying return air shall not
be prohibited.

1 3. Where located within tenant spaces of 1,000 square feet (93 m²) or less in area, use of
2 corridors for conveying return air is permitted.

3 4. Incidental air movement from pressurized rooms within health care facilities, provided that
4 the corridor is not the primary source of supply or return to the room.

5 [W] 5. Where such air is part of an engineered smoke control system.

6 [W] 6. Air supplied to corridors serving residential occupancies shall not be considered as
7 providing ventilation air to the dwelling units and sleeping units subject to the following:

8 6.1 The air supplied to the corridor is one hundred percent outside air; and

9 6.2 The dwelling units have conforming ventilation air independent of the air supplied to
10 the corridor; and

11 6.3 For other than high-rise buildings, the supply fan will automatically shut off upon
12 activation of corridor smoke detectors installed in accordance with Section 606.2; or

13 6.4 For high-rise buildings, the supply fan will automatically shut off upon activation of
14 the smoke detectors required by *Seattle Fire Code* Section 907.2.13.1 or upon receipt

15 of another *approved* fire alarm signal. The supply fan is not required to be

16 automatically shut off when used as part of an *approved* building stairwell or elevator

17 hoistway pressurization system. Corridor smoke detectors shall be installed in

18 accordance with Section 606.2.

19 * * *

20 **SECTION 602**

21 **PLENUMS**

22 [W]602.1 General. Supply, return, exhaust, relief and ventilation air plenums shall be limited to
23 uninhabited crawl spaces, areas above a ceiling or below the floor, attic spaces and mechanical

1 equipment rooms. Plenums shall be limited to one fire area. Air systems that serve multiple fire
2 areas shall be ducted from the boundary of the fire area served directly to the air-handling
3 equipment. Fuel-fired appliances shall not be installed within a plenum.

4 **602.2 Construction.** *Plenum* enclosure construction materials that are exposed to the airflow
5 shall comply with the requirements of Section 703.5 of the *International Building Code* or such
6 materials shall have a flame spread index of not more than 25 and a smoke-developed index of
7 not more than 50 when tested in accordance with ASTM E 84 or UL 723.

8 The use of gypsum boards to form plenums shall be limited to systems where the air
9 temperatures do not exceed 125°F (52°C) and the building and mechanical system design
10 conditions are such that the gypsum board surface temperature will be maintained above the
11 airstream dew-point temperature as determined by the registered design professional. Air
12 plenums formed by gypsum boards shall not be incorporated in air-handling systems utilizing
13 evaporative coolers.

14 * * *

15 **602.2.1.1 Wiring.** Combustible electrical wires and cables and optical fiber cables
16 exposed within a plenum shall be listed as having a maximum peak optical density of
17 0.50 or less, an average optical density of 0.15 or less, and a maximum flame spread
18 distance of 5 feet (1524 mm) or less when tested in accordance with NFPA 262 or shall
19 be installed in metal raceways or metal sheathed cable. Combustible optical fiber and
20 communication raceways exposed within a plenum shall be listed as having a maximum
21 peak optical density of 0.5 or less, an average optical density of 0.15 or less, and a
22 maximum flame spread distance of 5 feet (1524 mm) or less when tested in accordance
23 with ANSI/UL 2024. Only plenum-rated wires and cables shall be installed in plenum-

1 rated raceways. Electrical wires and cables, optical fiber cables and raceways addressed
2 in this section shall be listed and labeled and shall be installed in accordance with the
3 Seattle Electrical Code (~~NEPA-70~~).

4 * * *

5 SECTION 603

6 DUCT CONSTRUCTION AND INSTALLATION

7 * * *

8 **603.5.1 Gypsum ducts.** The use of gypsum boards to form air shafts (ducts) shall be limited
9 to return air systems where the air temperatures do not exceed 125°F (52°C) and the gypsum
10 board surface temperature is maintained above the airstream dew-point temperature as
11 determined by the registered design professional. Air ducts formed by gypsum boards shall
12 not be incorporated in air-handling systems utilizing evaporative coolers.

13 **Exceptions:**

- 14 1. Gypsum boards may be used for ducts that are only used for stairway or elevator
15 pressurization supply air. The gypsum duct shall not attach directly to the equipment.
16 2. Gypsum boards coated on the inside with epoxy paint or foil-facing may be used
17 for ventilation systems serving parking garages.
18 3. Gypsum boards coated on the inside with epoxy paint or foil-facing may be used
19 for exhaust air ducts.

Note: Gypsum ducts shall be sealed in accordance with *International Energy*
Conservation Code Section C403.2.7.

20 * * *

1 **[W] 605.4 Particulate matter removal.** Particulate matter filters or air cleaners having a
2 minimum efficiency reporting value (MERV) of not less than 6 for ducted air handlers and not
3 less than 4 for ductless mini-split systems shall be provided upstream of all cooling coils or other
4 devices with wetted surfaces through which air is supplied to an occupiable space.

5 SECTION 606

6 SMOKE DETECTION SYSTEMS CONTROL

7 * * *

8 **606.2 Where required.** Smoke detectors shall be installed where indicated in Sections 606.2.1
9 through ~~((606.2.3))~~ 606.2.5.

10 **Exception:** Smoke detectors shall not be required where air distribution systems are
11 incapable of spreading smoke beyond the enclosing walls, floors and ceilings of the room or
12 space in which the smoke is generated.

13 **606.2.1 Return air systems.** Smoke detectors shall be installed in return air systems with a
14 design capacity greater than 2,000 cfm (0.9 m³/s), in the return air duct or *plenum* upstream
15 of any filters, *exhaust air* connections, outdoor air connections, or decontamination
16 *equipment* and appliances.

17 **[W]Exception:**

18 1. Smoke detectors are not required in the return air system where all portions of the
19 building served by the air distribution system are protected by area smoke detectors
20 connected to a fire alarm system in accordance with the *International Fire Code*. The
21 area smoke detection system shall comply with Section 606.4.

1 mechanically ventilated with supply air shall be equipped with smoke detectors spaced in
2 accordance with NFPA 72. The supply fan shall automatically shut off upon activation of the
3 corridor smoke detectors.

4 **Exception:** Corridor smoke detection is not required when air is returned back to the
5 supply fan from the corridor and return air smoke detectors are installed in the return air
6 duct or plenum upstream of any filters, exhaust air connections, outdoor air connections,
7 or decontamination equipment and appliances designed to automatically shut off the
8 supply fan.

9 **606.2.5 Corridors Serving Group R Occupancies in high-rise buildings.** Corridors that
10 serve Group R occupancies in high-rise buildings and that are mechanically ventilated with
11 supply air shall be equipped with smoke detectors that are spaced in accordance with NFPA
12 72 and air supply inlets to the corridor shall be provided with smoke/fire dampers. The
13 supply inlet smoke/fire dampers shall automatically close upon activation of the corridor
14 smoke detectors.

15 **Exceptions:**

16 1. Corridor smoke detection is not required to close the supply inlet smoke/fire
17 dampers when the smoke/fire dampers are used as part of an *approved* building
18 stairwell or elevator hoistway pressurization smoke control system.

19 2. Corridor smoke detection is not required when, air is returned back to the supply
20 fan from the corridor and return air smoke detectors are installed in the return air
21 duct or plenum upstream of any filters, exhaust air connections, outdoor air
22 connections, or decontamination equipment and appliances designed to
23 automatically shut off the supply fan.

* * *

1
2 **[F] 606.4.1 Supervision.** The duct smoke detectors shall be connected to the building's fire
3 alarm control unit (~~(a fire alarm system)~~) where a fire alarm system is required by Section
4 907.2 of the *International Fire Code*. Duct detectors shall not activate a fire alarm signal.
5 The actuation of a duct smoke detector shall activate a visible and audible supervisory signal
6 at a constantly attended location. In facilities that are required to be monitored by a
7 supervising station, duct smoke detectors shall report only as a supervisory signal, not as a
8 fire alarm.

9 **Exceptions:**

- 10 1. The supervisory signal at a constantly attended location is not required where the
11 duct smoke detector activates the building's alarm-indicating appliances.
12 2. In occupancies not required to be equipped with a fire alarm system, actuation of a
13 smoke detector shall activate a visible and audible signal in an *approved* location.
14 Duct smoke detector trouble conditions shall activate a visible or audible signal in
15 an *approved* location and shall be identified as air duct detector trouble.

16 **SECTION 607**

17 **DUCT AND TRANSFER OPENINGS**

18 * * *

19 **[BF] 607.3.3.1 Fire damper actuation device.** The fire damper actuation device shall
20 meet one of the following requirements:

- 21 1. The operating temperature shall be approximately 50°F (28°C) above the normal
22 temperature within the duct system, but not less than 160°F (71°C).

CHAPTER 7
COMBUSTION AIR

SECTION 701

GENERAL

1 **701.1 Scope.** This chapter shall apply to oil-burning appliances and equipment to ensure that
2 adequate air for safe combustion is provided. Solid fuel-burning *appliances, fireplaces and*
3 *fireplace stoves* shall be provided with *combustion air* in accordance with the appliance
4 manufacturer's installation instructions and International Building Code Section 2111. (~~Oil-~~
5 ~~fired appliances shall be provided with combustion air in accordance with NFPA 31. The~~
6 ~~methods of providing combustion air in this chapter do not apply to fireplaces, fireplace stoves~~
7 ~~and d))~~ Direct-vent appliances shall be provided with combustion air in accordance with the
8 appliance manufacturer's installation instructions. The requirements for combustion and dilution
9 air for gas-fired *appliances* shall be in accordance with the *International Fuel Gas Code*.

12 * * *

13 **701.3 Oil-burning appliance and equipment installation location.** Oil-burning appliances and
14 equipment shall be installed in locations where available ventilation permits satisfactory
15 combustion of oil, proper venting of combustion gases, and maintenance of safe ambient
16 temperatures under normal conditions of use. Appliances shall be located so that they do not
17 interfere with the supply of air within the space.

18 **Note:** The provisions of Chapter 7 are based on NFPA 31-2011.

19 **701.4 Tight construction.** Where buildings are so tight that normal infiltration does not provide
20 sufficient air for combustion, outside air shall be introduced.

1 **701.5 Combustion air ducts.** Combustion air ducts shall:

2 1. Be of galvanized steel complying with Chapter 6 or of equivalent corrosion-resistant
3 material approved for this application.

4 **Exception:** Within dwelling units, unobstructed stud and joist spaces shall not be
5 prohibited from conveying combustion air, provided that not more than one required
6 fireblock is removed.

7 2. Have a minimum cross-sectional dimension of 3 inches (76 mm).

8 3. Terminate in an unobstructed space allowing free movement of combustion air to the
9 appliances.

10 4. Have the same cross-sectional areas as the free area of the openings to which they connect.

11 5. Serve a single appliance enclosure.

12 6. Not serve both upper and lower combustion air openings where both such openings are
13 used. The separation between ducts serving upper and lower combustion air openings shall
14 be maintained to the source of combustion air.

15 7. Not be screened where terminating in an attic space.

16 8. Not slope downward toward the source of combustion air, where serving the upper
17 required combustion air opening.

18 **701.6 Prohibited sources.** Openings and ducts shall not connect appliance enclosures with a
19 space in which the operation of a fan will adversely affect the flow of the combustion air.

20 Combustion air shall not be obtained from a hazardous location, except where the fuel-fired
21 appliances are located within the hazardous location and are installed in accordance with this
22 code. Combustion air shall not be taken from a refrigeration machinery room, except where a
23 refrigerant vapor detector system is installed to automatically shut off the combustion process in

1 the event of refrigerant leakage. Combustion air shall not be obtained from any location below
2 the design flood elevation.

3 **701.7 Opening location and protection.** Combustion air openings to the outdoors shall comply
4 with the location and protection provisions of Sections 401.4 and 401.5 applicable to outdoor air
5 intake openings.

6 **SECTION 702**

7 **APPLIANCES LOCATED IN UNCONFINED SPACES**

8 **702.1 Unconfined spaces.** In unconfined spaces air for combustion and ventilation shall be
9 obtained directly from outdoors or from spaces that freely communicate with outdoors by means
10 of a permanent opening or openings having a total free area of not less than 1 in.² per 5000
11 Btu/hr (28 in.² per gal/hr) (4.4 cm² kW), based on the total input rating of all appliances in the
12 space.

13 **Exception:** In buildings built prior to the 1986 edition of the *Washington State Energy Code*
14 with *Seattle Amendments*, air for combustion shall be permitted to be supplied by normal
15 infiltration.

16 **SECTION 703**

17 **APPLIANCES LOCATED IN CONFINED SPACES**

18 **703.1 Confined spaces.** For appliances installed in confined spaces, air for combustion and
19 ventilation shall be provided using one of the methods set forth in this section.

20 **703.2 All air taken from inside the building.** Where all combustion air will be taken from
21 inside the building, the confined space shall be provided with two permanent openings as shown
22 in Figure 703.2.1, one near the top of the space and one near the bottom.

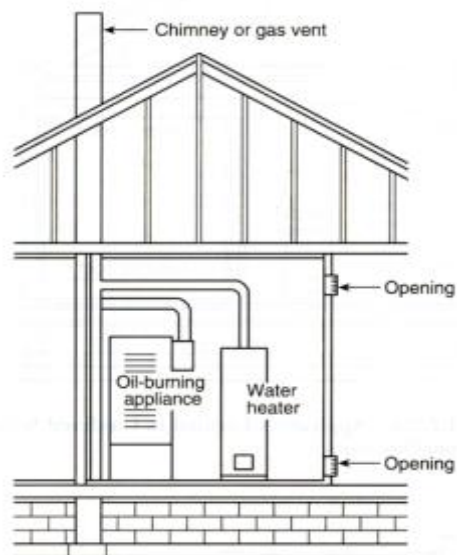

FIGURE 703.2.1 Appliances Located in Confined Spaces – All Air Taken from Inside the Building

703.2.1 Size of openings. Each opening shall have a free area of not less than 1 in.² per 1000 Btu/hr (140in.² per gal/hr) (22 cm²/kW), based on the total input rating of all appliances in the space.

703.2.2 Source of air. Each opening shall freely communicate with interior areas of the building that, in turn, have adequate infiltration from the outside.

703.3 All air taken from outdoors. Where all air will be taken from outdoors, the confined space shall be provided with two permanent openings, one near the top of the space and one in or near the bottom.

703.3.1 Source of air. The openings shall communicate directly or by means of ducts with the outdoors or to spaces such as an attic or crawl space, that themselves freely communicate with the outdoors, as shown in Figure 703.3.2.1, Figure 703.3.2.2, and Figure 703.3.2.3.

1 **703.3.2 Vertical ducts.** Where communicating with the outdoors directly or by means of
2 vertical ducts, each opening shall have a free area of not less than 1 inch² per 4000 Btu/hr (35
3 inch² per gal/hr) (5.5 cm²/kW), based on the total input rating of all appliances in the space.

4 **703.3.3 Horizontal ducts.** Where communicating with the outdoors by means of horizontal
5 ducts, each opening shall have a free area of not less than 1 inch² per 2000 Btu/hr (70 inch²
6 per gal/hr) (11 cm²/kW), based on the total input rating of all appliances in the space.

7



8 **FIGURE 703.3.2.1 Appliances Located in Confined**
9 **Spaces - All Air from Outdoors**

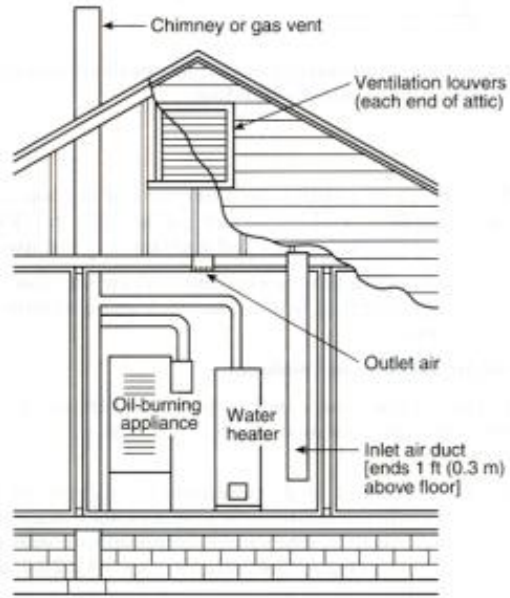

1
2

FIGURE 703.3.2.2 Appliances Located in Confined Spaces - All Air from Outdoors Through Ventilated Attic

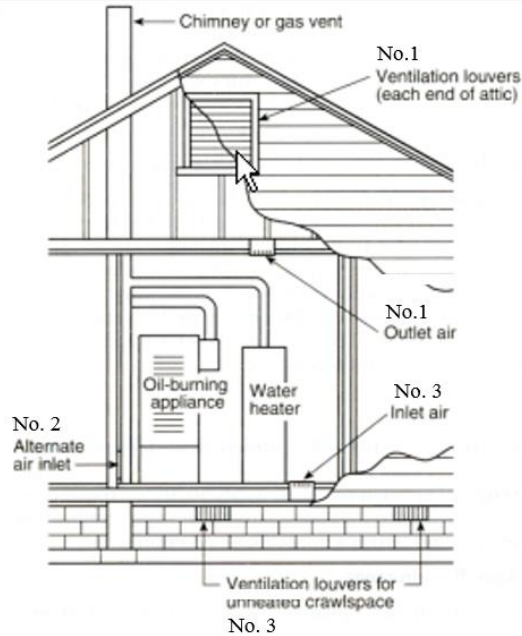

1

Notes:

- Ducts used for make-up air can be connected to the cold air return of the heating system only if they connect directly to outdoor air.
- Nos. 1, 2, and 3 mark alternate locations for air from outdoors.
- Provide attic ventilation louvers at each end of attic with alternate air inlet No. 1.
- Provide crawl space ventilation louvers for unheated crawl space with alternate air inlet No. 3.

2 **FIGURE 703.3.2.3 Appliances Located in Confined Spaces, with ventilation air from inside**
3 **building and combustion air from outside, ventilated attic, or ventilated crawl space.**

4 **703.4 Ventilation air taken from inside the building—combustion air taken from outdoors.**

5 **Where ventilation air will be taken from inside the building and combustion air will be taken**

1 from outdoors, the confined space shall be provided with two openings for ventilation, located
2 and sized as specified in Section 703.2 and as shown in Figure 703.3.2.3. In addition, there shall
3 be one opening communicating directly with the outdoors or to spaces, such as an attic or crawl
4 space, that freely communicates with the outdoors and has a free area of not less than 1 in.² per
5 5000 Btu/hr (28 in.² per gal/hr) (4.4 cm²/kW), based on the total input of all appliances in the
6 space.

7 **SECTION 704**

8 **COMBUSTION AIR FOR COMMERCIAL AND INDUSTRIAL INSTALLATIONS**

9 **704.1 General.** For commercial and industrial oil-burning equipment, permanent means for
10 supplying an ample amount of outside air shall be provided in accordance with this section.

11 **704.2 Size of openings.** For furnace or boiler rooms adjacent to outside walls and where
12 combustion air is provided by natural ventilation from the outside, there shall be a permanent air
13 supply inlet having a total free area of not less than 1 in.² per 4000 Btu/hr (35 in.² per gal/hr)
14 (5.5 cm²/kW), based on the total input rating of the burner or burners, but in no case less than 35
15 in.² (0.425 m²). For furnace or boiler rooms that are not adjacent to outside walls, the combustion
16 air shall be supplied in a manner acceptable to the building official.

17 **SECTION 705**

18 **LOUVERS AND GRILLES**

19 **705.1 Louvers and grilles.** In calculating the free area required by Sections 701, 702, 703 and
20 704, the blocking effect of louvers, grilles, or screens protecting openings shall be taken into
21 consideration.

22 **705.2 Screens.** Screens used in louvers or grilles shall not be smaller than 1/4 in (6.3 mm) mesh
23 and shall be accessible for cleaning.

1 **705.3 Size of openings.** If the free area through a particular design of louver or grille is known, it
2 shall be used in calculating the size of the opening needed to provide the free area required. If the
3 free area of the design is not known, it shall be assumed that wood louvers will have 20 percent
4 to 25 percent free area and metal louvers and grilles will have 60 percent to 75 percent free area.

5 **SECTION 706**

6 **SPECIAL CONDITIONS**

7 **706.1 Special conditions.** Where an appliance is installed in a location where the operation of
8 exhaust fans, kitchen ventilation systems, clothes dryers or fireplaces can create conditions of
9 unsatisfactory combustion or venting, special provisions shall be made subject to the approval of
10 the building official.

11 Section 10. The following sections of Chapter 8 of the International Mechanical Code,
12 2015 Edition, are amended as follows:

13 **CHAPTER 8**

14 **CHIMNEYS AND VENTS**

15 * * *

16 **SECTION 804**

17 **DIRECT-VENT, INTEGRAL VENT AND MECHANICAL DRAFT SYSTEMS**

18 **804.3 Mechanical draft systems.** Mechanical draft systems of either forced or induced draft
19 design shall be listed and labeled in accordance with UL 378 and shall comply with Sections
20 804.3.1 through ~~((804.3.7))~~ 804.3.8.

21 * * *

804.3.4 Horizontal terminations. Horizontal terminations shall comply with the following
requirements:

- 1 1. Where located adjacent to walkways, the termination of mechanical draft systems shall
2 be not less than ((7)) 10 feet (((2134)) 3048 mm) above the level of the walkway.
- 3 2. Vents shall terminate at least 3 feet (914 mm) above any forced air inlet located within
4 10 feet (3048 mm).
- 5 3. The vent system shall terminate at least 4 feet (1219 mm) below, 4 feet (1219 mm)
6 horizontally from or 1 foot (305 mm) above any door, window or gravity air inlet into
7 the building.
- 8 4. The vent termination point shall not be located closer than 3 feet (914 mm) to an
9 interior corner formed by two walls perpendicular to each other.
- 10 5. The vent termination shall not be mounted directly above or within 3 feet (914 mm)
11 horizontally from an oil tank vent or gas meter.
- 12 6. The bottom of the vent termination shall be located at least 12 inches (305 mm) above
13 finished grade.

14 **804.3.5 Vertical terminations.** Vertical terminations shall comply with the following
15 requirements:

- 16 1. Where located adjacent to walkways, the termination of mechanical draft systems shall
17 be not less than ((7)) 10 feet (((2134)) 3048 mm) above the level of the walkway.
- 18 2. Vents shall terminate not less than 3 feet (914 mm) above any forced air inlet located
19 within 10 feet (3048 mm) ((~~horizontally~~)).
- 20 3. Where the vent termination is located below an adjacent roof structure, the termination
21 point shall be located not less than 3 feet (914 mm) from such structure.

1 Section 12. The following sections of Chapter 11 of the International Mechanical Code,
2 2015 Edition, are amended as follows:

CHAPTER 11

REFRIGERATION

SECTION 1101

GENERAL

* * *

3
4
5
6 **1101.4 Water connection.** Water supply and discharge connections associated with refrigeration
7 systems shall be made in accordance with this code and the (~~International~~) Uniform Plumbing
8 Code.

* * *

SECTION 1104

SYSTEM APPLICATION REQUIREMENTS

* * *

9
10
11
12
13 **1104.2.2 Industrial occupancies and refrigerated rooms.** This section applies only to
14 industrial occupancies and refrigerated rooms for manufacturing, food and beverage
15 preparation, meat cutting, other processes and storage.

16 Machinery rooms are not required where all of the following conditions are met:

- 17 1. The space containing the machinery is separated from other occupancies by tight
18 construction with tight-fitting doors.
- 19 2. Access is restricted to authorized personnel.
- 20 3. The floor area per occupant is not less than 100 square feet (9.3 m²) where machinery
21 is located on floor levels with exits more than 6.6 feet (2012 mm) above the ground.

1 **1105.6.3 Ventilation rate other than ammonia systems.** For other than ammonia systems,
2 the mechanical ventilation systems shall be capable of exhausting the minimum quantity of
3 air both at normal operating and emergency conditions, as required by Sections 1105.6.3.1
4 and 1105.6.3.2. (~~The minimum required ventilation rate for ammonia shall be 30 air changes~~
5 ~~per hour in accordance with IAR2~~). Multiple fans or multispeed fans shall be allowed to
6 produce the emergency ventilation rate and to obtain a reduced airflow for normal
7 ventilation.

8 **1105.6.3.1 Quantity—normal ventilation.** During occupied conditions, the mechanical
9 ventilation system shall exhaust the larger of the following:

- 10 1. Not less than 0.5 cfm per square foot (0.0025 m³/s • m²) of *machinery room* area
11 (~~or 20 cfm (0.009 m³/s) per person~~).
- 12 2. A volume required to limit the room temperature rise to 18°F (10°C) taking into
13 account the ambient heating effect of all machinery in the room.
- 14 3. Not less than 20 cfm (0.009 m³/s) per person.

15 **1105.6.3.1.1 Quantity—unoccupied condition.** During unoccupied conditions, the
16 mechanical ventilation system is permitted to exhaust the larger of the following:

- 17 1. Not less than 0.25 cfm per square foot (0.00125 m³/s • m²) of machinery
18 room area; or
- 19 2. A volume required to limit the room temperature rise to 18°F (10°C) taking
20 into account the ambient heating effect of all machinery in the room.

21 The system shall be provided with controls that increase the ventilation to the rate
22 required for occupied spaces when the space is illuminated.

23 * * *

1 **1105.6.4 Ventilation rate—ammonia.** The minimum required normal and emergency
2 ventilation rates for ammonia shall be in accordance with IIAR2 and Sections 1105.6.4.1 and
3 1105.6.4.2.

4 **1105.6.4.1 Quantity—normal ventilation.** During normal conditions, the mechanical
5 ventilation system shall exhaust the larger of the following:

- 6 1. Not less than 2 cfm per square foot (0.01 m³/s • □m²) of machinery room area; or
- 7 2. A volume required to limit the room temperature rise to 18°F (10°C) taking into
8 account the ambient heating effect of all machinery in the room; or
- 9 3. Not less than 5 air changes per hour.

10 **1105.6.4.2 Quantity—emergency conditions.** Upon actuation of the refrigerant detector
11 required in Section 1105.3, the mechanical ventilation system shall exhaust air from the
12 machinery room at a rate of not less than 30 air changes per hour or in accordance with
13 IIAR 2.

14 **[F] 1105.6.5 Standby source of power required.** Where *mechanical ventilation, treatment*
15 systems, temperature control, alarm, detection or other electrically operated systems are
16 required, such systems shall be provided with a legally-required standby source of power.
17 See the *International Building Code Chapter 27 and Seattle Electrical Code Article 701.*

18 **Exception:** Legally required standby power is not required where an approved fail-safe
19 engineered system is installed.

20 **1105.7 Termination of relief devices.** Pressure relief devices, fusible plugs and purge systems
21 located within the *machinery room* shall terminate outside of the structure at a location not less
22 than 15 feet (4572 mm) above the adjoining grade level and not less than 20 feet (6096 mm)
23 from any window, ventilation opening or exit.

1 **[W]1107.2 Piping location.** Refrigerant piping that crosses an open space that affords
2 passageway in any building shall be not less than 7 feet 3 inches (2210 mm) above the floor
3 unless the piping is located against the ceiling of such space. Refrigerant piping shall not be
4 placed in any of the following:

5 1.A fire-resistance-rated exit access corridor;

6 2.An interior exit stairway;

7 3.An interior exit ramp;

8 4. An exit passageway.

9 5. An elevator, dumbwaiter or other shaft containing a moving object (~~or in any shaft that~~
10 has openings to living quarters)); or

11 6. A shaft that has one or more openings into (~~to means of egress. Refrigerant piping shall~~
12 not be installed in an enclosed public)) a fire-resistance-rated exit access corridor, interior
13 exit stairway or ramp, or exit passageway (~~stairway landing or means of egress~~)).

14 **Exceptions:**

15 1.Refrigerant piping and equipment is permitted to be separated from the corridor, stair,
16 passageway by construction equal to the rated construction of the space and located so
17 that all required clearances are maintained.

18 2.Refrigerant piping is permitted to pass through corridors if located above a ceiling and
19 the piping has no joints in the corridor.

20 3.Refrigerant piping is permitted to pass through lobbies that are part of an exit system if
21 the refrigeration system contains not more that the amount of refrigerant allowed by
22 Section 1104.3.

23 * * *

1 Section 13. The following sections of Chapter 12 of the International Mechanical Code,
2 2015 Edition, are amended as follows:

CHAPTER 12

HYDRONIC PIPING

3 SECTION 1201

4 GENERAL

5 **1201.1 Scope.** The provisions of this chapter shall govern the construction, installation,
6 *alteration* and repair of hydronic piping systems. This chapter shall apply to hydronic piping
7 systems that are part of heating, ventilation and air-conditioning systems. Such piping systems
8 shall include steam, hot water, chilled water, steam condensate and ground source heat pump
9 loop systems. Potable cold and hot water distribution systems shall be installed in accordance
10 with the ((*International*)) Uniform Plumbing Code.

11 * * *

12 SECTION 1206

13 PIPING INSTALLATION

14 * * *

15 **1206.2 System drain down.** Hydronic piping systems shall be designed and installed to permit
16 the system to be drained. Where the system drains to the plumbing drainage system, the
17 installation shall conform to the requirements of the ((*International*)) Uniform Plumbing Code.

18 **Exception:** The buried portions of systems embedded underground or under floors.

19 **1206.3 Protection of potable water.** The potable water system shall be protected from backflow
20 in accordance with the ((*International*)) Uniform Plumbing Code.

21 * * *

1 Section 14. The following sections of Chapter 14 of the International Mechanical Code,
2 2015 Edition, are amended as follows:

3 **CHAPTER 14**
4 **SOLAR SYSTEMS**
5 **SECTION 1401**
6 **GENERAL**

7 **1401.1 Scope.** This chapter shall govern the design, construction, installation, *alteration* and
8 repair of systems, *equipment* and appliances intended to utilize solar energy for space heating or
9 cooling, domestic hot water heating, swimming pool heating or process heating. Photovoltaic
10 solar systems shall be installed in accordance with the *International Building Code* and Article
11 690 of the *Seattle Electrical Code*. Systems interconnected to the electric grid shall comply with
12 additional requirements of Seattle City Light.

13 **Note:** See the Seattle Boiler and Pressure Vessel Code for regulations applicable to boilers
14 and pressure vessels, and the *Uniform Plumbing Code* for regulations applicable to water
15 heaters.

16 **1401.2 Potable water supply.** Potable water supplies to solar systems shall be protected against
17 contamination in accordance with the ((~~*International*~~)) *Uniform Plumbing Code*.

18 **Exception:** Where all solar system piping is a part of the potable water distribution system,
19 in accordance with the requirements of the ((~~*International*~~)) *Uniform Plumbing Code*, and all
20 components of the piping system are *listed* for potable water use, cross-connection protection
measures shall not be required.

* * *

1 Section 19. Section 16 of this ordinance shall take effect January 1, 2017.

2 Section 20. This ordinance shall take effect and be in force 30 days after its approval by
3 the Mayor, but if not approved and returned by the Mayor within ten days after presentation, it
4 shall take effect as provided by Seattle Municipal Code Section 1.04.020.

5 Passed by the City Council the _____ day of _____, 2016,
6 and signed by me in open session in authentication of its passage this _____ day of
7 _____, 2016.

8 _____
9 President _____ of the City Council

10 Approved by me this _____ day of _____, 2016.

11 _____
12 Edward B. Murray, Mayor

13 Filed by me this _____ day of _____, 2016.

14 _____
15 Monica Martinez Simmons, City Clerk

16 (Seal)