



# SEATTLE CITY COUNCIL

## Parks, Public Utilities, and Technology Committee

### Agenda

#### Public Hearing

Wednesday, June 26, 2024

2:00 PM

Council Chamber, City Hall  
600 4th Avenue  
Seattle, WA 98104

Joy Hollingsworth, Chair  
Sara Nelson, Vice-Chair  
Robert Kettle, Member  
Maritza Rivera, Member  
Dan Strauss, Member

Chair Info: 206-684-8803; [Joy.Hollingsworth@seattle.gov](mailto:Joy.Hollingsworth@seattle.gov)

[Watch Council Meetings Live](#) [View Past Council Meetings](#)

Council Chamber Listen Line: 206-684-8566

The City of Seattle encourages everyone to participate in its programs and activities. For disability accommodations, materials in alternate formats, accessibility information, or language interpretation or translation needs, please contact the Office of the City Clerk at 206-684-8888 (TTY Relay 7-1-1), [CityClerk@Seattle.gov](mailto:CityClerk@Seattle.gov), or visit <https://seattle.gov/cityclerk/accommodations> at your earliest opportunity. Providing at least 72-hour notice will help ensure availability; sign language interpreting requests may take longer.



**SEATTLE CITY COUNCIL**  
**Parks, Public Utilities, and Technology Committee**  
**Agenda**  
**June 26, 2024 - 2:00 PM**  
**Public Hearing**

**Meeting Location:**

Council Chamber, City Hall , 600 4th Avenue , Seattle, WA 98104

**Committee Website:**

<https://www.seattle.gov/council/committees/parks-public-utilities-and-technology-x154106>

---

This meeting also constitutes a meeting of the City Council, provided that the meeting shall be conducted as a committee meeting under the Council Rules and Procedures, and Council action shall be limited to committee business.

Members of the public may register for remote or in-person Public Comment to address the Council. Details on how to provide Public Comment are listed below:

Remote Public Comment - Register online to speak during the Public Comment period at the meeting at

<https://www.seattle.gov/council/committees/public-comment>

Online registration to speak will begin one hour before the meeting start time, and registration will end at the conclusion of the Public Comment period during the meeting. Speakers must be registered in order to be recognized by the Chair.

In-Person Public Comment - Register to speak on the Public Comment sign-up sheet located inside Council Chambers at least 15 minutes prior to the meeting start time. Registration will end at the conclusion of the Public Comment period during the meeting. Speakers must be registered in order to be recognized by the Chair.

Pursuant to Council Rule VI.C.10, members of the public providing public comment in Chambers will be broadcast via Seattle Channel.

Submit written comments to Councilmembers at [Council@seattle.gov](mailto:Council@seattle.gov).

*Please Note: Times listed are estimated*

**A. Call To Order**

**B. Approval of the Agenda**

**C. Public Comment**

**D. Items of Business**

1. [CB 120800](#) **AN ORDINANCE relating to current use taxation; approving an application for current use taxation of property located at 4613 South Lucile Street under the King County Public Benefit Rating System.**

Attachments: [Att 1 - King County Department of Natural Resources and Parks report on application E23CT003S](#)

Supporting Documents: [Summary and Fiscal Note](#)  
[Central Staff Memo](#)  
[Presentation](#)

**Public Hearing, Briefing, Discussion, and Possible Vote** (20 minutes)

**Presenters:** Bill Bernstein, King County; Yolanda Ho, Council Central Staff

2. **Ship Canal Water Quality Project Update**

Supporting Documents: [Presentation](#)

**Briefing and Discussion** (25 minutes)

**Presenter:** Andrew Lee, General Manager and CEO, and Keith Ward, Seattle Public Utilities

3. [Res 32136](#) **A RESOLUTION relating to Seattle Public Utilities; adopting a 2025-2030 Strategic Business Plan for Seattle Public Utilities; and endorsing a three-year (2025-2027) rate path and a subsequent, three-year (2028-2030) rate forecast to support the Strategic Business Plan Update.**

Attachments: [Att 1 – SPU 2025-2030 Strategic Business Plan Update](#)  
[Att 1 Appendix A - 2025-2030 Highlighted Initiatives and Investments Detail](#)  
[Att 1 Appendix B – Community Research and Outreach Summary](#)  
[Att 1 Appendix C – Financial Forecast](#)  
[Att 1 Appendix D - Affordability and Accountability Overview](#)  
[Att 1 Appendix E - Customer Review Panel Comment Letter](#)

Supporting Documents: [Summary and Fiscal Note](#)  
[Summary Ex A – SPU Financial Summary Report](#)  
[Summary Ex B - Executive Summary Presentation](#)

**Briefing and Discussion** (60 minutes)

**Presenters:** Andrew Lee, General Manager and CEO, Danielle Purnell, and Karl Stickel, Seattle Public Utilities; Brian Goodnight, Council Central Staff

## E. Adjournment



Legislation Text

---

**File #:** CB 120800, **Version:** 1

---

**CITY OF SEATTLE**

**ORDINANCE \_\_\_\_\_**

**COUNCIL BILL \_\_\_\_\_**

AN ORDINANCE relating to current use taxation; approving an application for current use taxation of property located at 4613 South Lucile Street under the King County Public Benefit Rating System.

WHEREAS, the King County Department of Natural Resources and Parks has forwarded an application to the

City Council for classification under the King County Public Benefit Rating System (PBRs); and

WHEREAS, GROW, a non-profit corporation, has applied for PBRs rating for open space on property that they

own located at 4613 South Lucile Street (E23CT003S); and

WHEREAS, the PBRs is administered in accordance with Revised Code of Washington (RCW) 84.34.037,

chapter 458-30 of the Washington Administrative Code, and chapter 20.36 of the King County Code

providing for assessment practices to reflect current use of property, rather than “highest and best use,”

as an incentive for property owners to maintain open space; and

WHEREAS, RCW 84.34.037(1) states that an application for PBRs shall be acted upon after public hearings

and affirmative acts by the county and city legislative bodies affirming the entirety of an application

without modification or both bodies affirm an application with identical modifications; and

WHEREAS, the Seattle City Council held a public hearing on the application on June 26, 2024; and

WHEREAS, the Seattle City Council concurs with the recommendations of the King County Department of

Natural Resources and Parks as contained in the report of the application attached to this ordinance; and

WHEREAS, the Metropolitan King County Council approved the application at its meeting on January 16,

2024; NOW, THEREFORE,

**BE IT ORDAINED BY THE CITY OF SEATTLE AS FOLLOWS:**

Section 1. The City Council approves the following application for the public benefit rating system subject to the conditions enumerated in the attached report:

A. E22CT021S: Application of GROW for property located at 4613 South Lucile Street, for open space purposes, 0.21 acres as described in Attachment 1 to this ordinance, the King County Department of Natural Resources and Parks report on application E23CT003S.

Section 2. This ordinance shall take effect as provided by Seattle Municipal Code Sections 1.04.020 and 1.04.070.

Passed by the City Council the \_\_\_\_\_ day of \_\_\_\_\_, 2024, and signed by me in open session in authentication of its passage this \_\_\_\_\_ day of \_\_\_\_\_, 2024.

\_\_\_\_\_

President \_\_\_\_\_ of the City Council

Approved / returned unsigned / vetoed this \_\_\_\_\_ day of \_\_\_\_\_, 2024.

\_\_\_\_\_

Bruce A. Harrell, Mayor

Filed by me this \_\_\_\_\_ day of \_\_\_\_\_, 2024.

---

Scheereen Dedman, City Clerk

(Seal)

Attachment:

Attachment 1 - King County Department of Natural Resources and Parks report on application E23CT003S

**KING COUNTY  
DEPARTMENT OF NATURAL RESOURCES AND PARKS  
WATER AND LAND RESOURCES DIVISION**

**Report to the City of Seattle for  
Property Enrollment in the Public Benefit Rating System (PBRs)**

**April 8, 2024**

**APPLICANT: GROW, Inc.**

**File No. E23CT003S**

**A. GENERAL INFORMATION:**

1. Owner: GROW, Inc. (represented by Eric Todderudd)  
PO Box 19748  
Seattle, WA 98109
2. Property location: 4613 South Lucille Street  
Seattle, WA 98118
3. Zoning: NR3
4. STR: SE-22-24-04
5. PBRs categories requested by applicant:

NOTE: Parcel -0530 is currently participating in PBRs (File No. E97CT099S). The landowner has reapplied to improve participation status on this parcel as well as enroll parcel -0510. The new open space taxation agreement should supersede the existing agreement for this property's PBRs participation.

**Open space resource**

\*Public recreation area

**Bonus categories**

\*Unlimited public access

\*Conservation easement or historic easement

\*Easement and access

NOTE: \*Staff recommends credit be awarded for these PBRs categories. Enrollment in PBRs for property within an incorporated area requires approval by impacted granting authorities following public hearing(s). For this application, the granting authorities are the King County Council and the City of Seattle. King County heard this application on November 29, 2023.

**EXHIBIT 1**



6. Parcel:	333150-0510	333150-0530
Total acreage:	0.07	0.14
Requested PBRS:	0.07	0.14
Home site/excluded area:	0.00	0.00
<b>Recommended PBRS:</b>	<b>0.07</b>	<b>0.14</b>

NOTE: The attached map (2021 aerial photo) outlines in yellow the parcel boundaries. The entire property (0.21 acres) is recommended for enrollment in PBRS. In the event the Assessor’s official parcel size is revised, PBRS acreage should be administratively adjusted to reflect that change.

**B. FACTS:**

1. Zoning in the vicinity: Properties in the vicinity are zoned NR3.
2. Development of the subject property and resource characteristics of open space area: The property is a community p-patch garden (known as the Hillman City P-Patch), and includes raised garden beds, walking paths and a shed used to store equipment used to maintain the gardens. The open space area consists of the entire property.
3. Site use: The property is used as a community garden.
4. Access: The property is accessed from South Lucille Street.
5. Appraised value for 2022 (based on Assessor’s information dated 11/9/2023):

<u>Parcel #333150-0510</u>	<u>Land</u>	<u>Improvements</u>	<u>Total</u>
Assessed value	<b>\$151,000</b>	\$0	\$151,000
Tax applied	<b>\$1,225</b>	\$0	\$1,225
<u>Parcel #333150-0530</u>	<u>Land</u>	<u>Improvements</u>	<u>Total</u>
Assessed value	<b>\$345,000*</b>	\$0	\$345,000
Tax applied	<b>\$2,802</b>	\$0	\$2,802

NOTE: \*This value is presently impacted by the land’s participation in the PBRS program, which is reflected in the land’s current and lower taxable value of \$172,500 (tax applied \$1,401). Participation in PBRS reduces the **appraised land value** for the **portion** of the property enrolled resulting in a lower taxable value.

## **C. REQUIREMENTS SPECIFIED BY KING COUNTY CODE (KCC):**

### **KCC 20.36.010 Purpose and intent.**

It is in the best interest of the county to maintain, preserve, conserve and otherwise continue in existence adequate open space lands for the production of food, fiber and forest crops, and to assure the use and enjoyment of natural resources and scenic beauty for the economic and social well-being of the county and its citizens.

It is the intent of this chapter to implement RCW Chapter 84.34, as amended, by establishing procedures, rules and fees for the consideration of applications for public benefit rating system assessed valuation on "open space land" and for current use assessment on "farm and agricultural land" and "timber land" as those lands are defined in RCW 84.34.020. The provisions of RCW chapter 84.34, and the regulations adopted thereunder shall govern the matters not expressly covered in this chapter.

### **KCC 20.36.100 Public benefit rating system for open space land – definitions and eligibility.**

- A. To be eligible for open space classification under the public benefit rating system, property must contain one or more qualifying open space resources and have at least five points as determined under this section. The department will review each application and recommend award of credit for current use of property that is the subject of the application. In making such recommendation, the department will utilize the point system described in section B. and C. below.
- B. The following open space resources are each eligible for the points indicated:
1. Active trail linkage – fifteen or twenty-five points
  2. Aquifer protection area – five points
  3. Buffer to public or current use classified land – three points
  4. Ecological enhancement land – eighteen points
  5. Equestrian-pedestrian-bicycle trail linkage – thirty-five points
  6. Farm and agricultural conservation land – five points
  7. Forest stewardship land – five points
  8. Historic landmark or archaeological site: buffer to a designated site – three points
  9. Historic landmark or archaeological site: designated site – five points
  10. Historic landmark or archaeological site: eligible site – three points
  11. Public recreation area – five points
  12. Rural open space – five points
  13. Rural stewardship land – five points
  14. Scenic resource, viewpoint, or view corridor – five points
  15. Significant plant or ecological site – five points
  16. Significant wildlife or salmonid habitat – five points
  17. Special animal site – three points
  18. Surface water quality buffer – five points, eight or ten total points
  19. Urban open space – five points
  20. Watershed protection area – five points

- C. Property qualifying for an open space category in subsection B. of this section may receive credit for additional points as follows:
1. Conservation easement or historic preservation easement – eighteen points
  2. Contiguous parcels under separate ownership – minimal two points
  3. Easement and access – thirty-five points
  4. Public access - points dependent on level of access
    - a. Unlimited public access - five points
    - b. Limited public access because of resource sensitivity - five points
    - c. Seasonal limited public access - three points
    - d. Environmental education access – three points
    - e. None or members only – zero points
  5. Resource restoration – five points

**D. 2020 COMPREHENSIVE PLAN POLICIES AND TEXT:**

**E-101** In addition to its regulatory authority, King County should use incentives to protect and restore the natural environment whenever practicable. Incentives shall be monitored and periodically reviewed to determine their effectiveness in terms of protecting natural resources.

NOTE: Monitoring of participating lands is the responsibility of both department PBRs staff and the landowner. This issue is addressed in the Resource Information document (page 4) and detailed below in Recommendation #B12.

**E-112a** The protection of lands where development would pose hazards to health, property, important ecological functions or environmental quality shall be achieved through acquisition, enhancement, incentive programs and appropriate regulations. The following critical areas are particularly susceptible and shall be protected in King County:

- a. Floodways of 100-year floodplains;
- b. Slopes with a grade of 40% or more or landslide hazards that cannot be mitigated;
- c. Wetlands and their protective buffers;
- d. Aquatic areas, including streams, lakes, marine shorelines and their protective buffers;
- e. Channel migration hazard areas;
- f. Critical Aquifer Recharge Areas;
- g. Fish and Wildlife Habitat Conservation Areas; and
- h. Volcanic hazard areas.

**E-421** Terrestrial and aquatic habitats should be conserved and enhanced to protect and improve conditions for fish and wildlife.

NOTE: PBRS is an incentive program provided to encourage voluntary protection of open space resources and maintain high quality resource lands.

**E-429** King County should provide incentives for private landowners who are seeking to remove invasive plants and noxious weeds and replace them with native plants, such as providing technical assistance or access to appropriate native plants.

NOTE: Participation in PBRS requires landowners address invasive plant and noxious weed control and removal within enrolled portions of a property. Replacement with native vegetation is also encouraged via the implementation of approved forest stewardship, rural stewardship or resource restoration plans.

**E-443** King County should promote voluntary wildlife habitat enhancement projects by private individuals and businesses through educational, active stewardship, and incentive programs.

**E-476** King County should identify upland areas of native vegetation that connect wetlands to upland habitats and that connect upland habitats to each other. The county should seek protection of these areas through acquisition, stewardship plans, and incentive programs such as the Public Benefit Rating System and the Transfer of Development Rights Program.

**E-504** King County should protect native plant communities by encouraging management and control of nonnative invasive plants, including aquatic plants. Environmentally sound methods of vegetation control should be used to control noxious weeds.

NOTE: Lands participating in PBRS provide valuable resource protection and promote the preservation or enhancement of native vegetation. Addressing nonnative vegetation (invasive plant species), through control and eradication is a PBRS requirement.

**E-449** King County shall promote retention of forest cover and significant trees using a mix of regulations, incentives, and technical assistance.

**R-605** Forestry and agriculture best management practices are encouraged because of their multiple benefits, including natural resource preservation and protection.

NOTE: The implementation of an approved forest stewardship, farm management or rural stewardship plan benefits natural resources, such as wildlife habitat, stream buffers and groundwater protection, as well as fosters the preservation of sustainable resources.

## E. PBRS CATEGORIES REQUESTED and DEPARTMENT RECOMMENDATIONS:

### Open space resource

- Public recreation area

The property is used as a community p-patch and individual gardeners are assigned beds in the p-patch. The general public may view and enjoy the garden and its grounds by walking through the property, with no barriers to access. Credit for this category is recommended. King County approved award of this category.

### Bonus categories

- Unlimited public access

The property is used as a community p-patch and the owner provides year-round and unlimited public access. Gardeners actively use the p-patch and the general public may view and enjoy the garden and its grounds by walking through the property, with no barriers to access. Credit for this category is recommended. King County approved award of this category.

- Conservation easement or historic easement

The landowner worked with the City of Seattle in 2006 to establish a conservation easement (recording #20060929002922) for the property, which protects valuable recreational resources, in particular the p-patch use, in perpetuity. Credit for this category is recommended. King County approved award of this category.

- Easement and access

The property qualifies for an open space resource category (public recreation area), provides unlimited public access and has a conservation easement in place (recording #20060929002922). Credit for this category is recommended. King County approved award of this category.

NOTE: It is important to note that enrollment in the PBRS program requires the control and removal of invasive plant species. This issue is addressed in the Resource Information document (page 3) and below in Recommendation #B6.

## CONCLUSIONS AND RECOMMENDATIONS

### A. CONCLUSIONS:

1. Approval of the subject request would be consistent with the specific purpose and intent of KCC 20.36.010.
2. Approval of the subject request would be consistent with policy E-101 of the King County Comprehensive Plan.
3. Of the points recommended, the subject request meets the mandatory criteria of KCC 20.36.100 as indicated:

### Open space resource

Public recreation area

5

**Bonus categories**

Unlimited public access	5
Conservation easement or historic easement	18
Easement and access	35

**TOTAL 63 points**

**PUBLIC BENEFIT RATING**

For the purpose of taxation, 63 points result in 10% of market value and a 90% reduction in taxable value for the portion of land enrolled.

**B. RECOMMENDATION:**

APPROVE the request for current use taxation "Open space" classification with a Public Benefit Rating of 63 points, subject to the following requirements:

**Requirements for Property Participating in the Public Benefit Rating System Current Use Assessment Program for Open Space**

1. Compliance with these requirements is necessary for property participating ("Property") in King County's Public Benefit Rating System ("PBRs"), a current use assessment program for open space. Failure to abide by these requirements can result in removal of PBRs designation and subject Property owner ("Owner") to penalty, tax, and interest provisions of RCW 84.34. King County Department of Assessments ("DoA") and King County Water and Land Resources Division, Agriculture, Forestry, and Incentives Unit, PBRs Program or its successor ("PBRs Program") may re-evaluate Property to determine whether removal of PBRs designation is appropriate. Removal shall follow the process in Chapter 84.34 RCW, Chapter 458.30 WAC and Chapter 20.36 KCC.
2. Revisions to any of these requirements may only occur upon mutual written approval of Owner and granting authority. These conditions shall apply so long as Property retains its PBRs designation. If a conservation easement acceptable to and approved by City of Seattle and King County is granted by Owner in interest to Department of Natural Resources and Parks, King County or a grantee approved by King County, these requirements may be superseded by the terms of such easement, upon written approval by PBRs Program.
3. The PBRs designation for Property will continue so long as it meets the PBRs criteria for which it was approved. Classification as open space will be removed upon a determination by PBRs Program that Property no longer meets PBRs criteria for which it was approved. A change in circumstances, which diminishes the extent of public benefit

from that approved by City of Seattle and King County Council in the open space taxation agreement, will be cause for removal of the PBRS designation. It is Owner's responsibility to notify DoA and PBRS Program of a change in Property circumstance, which may impact PBRS participation.

4. When a portion of Property is withdrawn or removed from the program, the remaining Property shall be re-evaluated by PBRS Program and DoA to determine whether it still meets the criteria for PBRS categories as approved.
5. Notwithstanding the provisions of Section 13, tree(s) posing a hazard to a structure, road or property access may be removed from Property, provided that Owner shall first notify the PBRS Program prior to taking such action. Native vegetation must be introduced for any tree(s) removed and must be planted within a reasonable location of where the tree(s) previously existed. It is Owner's responsibility to apply for and receive any necessary consent from applicable state and local governmental agencies for activities that may require a permit or approval.
6. If an area of Property becomes or has become infested with noxious weeds or non-native species, Owner may be required to submit a control and enhancement plan to PBRS Program in order to remove such vegetation and, if necessary, replace with native vegetation.
7. If it is determined by PBRS Program that Property vegetation near structures is prone to wildland fire and poses a fire hazard, management activities as allowed under KCC 16.82.051 may be implemented as long as those activities do not cause significant adverse impact to the resource values of awarded PBRS categories. Prior to undertaking any wildfire risk reduction activities on Property, a summary of any proposed work must first be submitted to and approved by PBRS Program.
8. There shall be no motorized vehicle driving or parking allowed on Property, except for medical, public safety or police emergencies, or for an approved management activity (such as forestry, farm, or restoration activities) detailed in an approved plan.
9. Grazing of livestock is prohibited unless Property is receiving credit for the farm and agricultural conservation land or resource restoration PBRS categories. In those cases, grazing may occur in areas being farmed as defined in the approved farm management plan or to be restored as defined in the approved resource restoration plan.
10. Passive recreational use and maintenance of associated improvements shall be permitted on Property receiving credit for public recreation area, active trail linkage, equestrian-pedestrian-bicycle trail linkage, or public access PBRS categories. Those uses and associated maintenance are allowed as long as they do not conflict with restrictions imposed by any of the awarded PBRS categories.

11. Public access shall be permitted upon any area of Property that is designated for public access.
12. Owner of Property participating in PBRS may be required to submit a monitoring report on an annual or less frequent basis as requested by the PBRS Program. This report must include a brief description of how Property still qualifies for each awarded resource category. It must also include photographs from established points on Property and any observations by Owner. If requested, Owner must submit this report to the PBRS Program by email, through the PBRS monitoring form provided on the PBRS Program's website, or by other mutually agreed upon method annually by December 31 or as directed by the PBRS Program. An environmental consultant need not prepare this report.
13. No alteration of Property or resources shall occur without prior written approval (such as an approved plan) by PBRS Program, except for selective cutting for personal firewood, maintaining areas for approved passive recreational uses (such as walking or horseback riding trails) or for removal of non-native species. **Any unapproved alteration may constitute a departure from an approved open space use and be deemed a change of use, and subject Owner to the additional tax, interest, and penalty provisions of RCW 84.34.080.** "Alteration" means any human-induced action that adversely impacts the existing condition of Property or resources including, but not limited to, the following:
  - a. erecting structures;
  - b. grading;
  - c. filling;
  - d. dredging;
  - e. channelizing;
  - f. modifying land or hydrology for surface water management purposes;
  - g. cutting, pruning, limbing or topping, clearing, mowing, or removing native vegetation;
  - h. introducing non-native species (as defined in KCC 21A.06.790);
  - i. applying herbicides or pesticides or any hazardous or toxic substance, without prior written approval;
  - j. discharging pollutants except for stormwater;
  - k. paving or application of gravel;
  - l. storing or dumping equipment, construction materials, garbage, vehicles, household supplies, or compost;
  - m. engaging in any other activity that adversely impacts existing native vegetation, hydrology, wildlife, wildlife habitat, or awarded program categories.
14. Participation in PBRS does not exempt Owner from obtaining any required permit or approval for activity or use on Property.



**TRANSMITTED** to the parties listed hereafter:

Eric Todderud, applicant representative  
Yolanda Ho, Legislative Analyst, Seattle City Council, Central Staff  
Elenore Bonyeau, King County Department of Assessments

2021 Aerial Photo

S LUCILE ST

46TH AVE S

47TH AVE S



3331500530

3331500510

## SUMMARY and FISCAL NOTE

<b>Department:</b>	<b>Dept. Contact:</b>	<b>CBO Contact:</b>
LEG	Yolanda Ho	N/A

### 1. BILL SUMMARY

**Legislation Title:** AN ORDINANCE relating to current use taxation; approving an application for current use taxation of properties located at 4613 South Lucile Street under the King County Public Benefit Rating System.

**Summary and Background of the Legislation:** This bill would approve an application for current use taxation under the Public Benefit Rating System (PBRs) administered by the King County Department of Natural Resources and Parks (DNRP), pursuant to RCW 84.34. The application is from the community gardening non-profit GROW, Inc., which owns the property and dedicates it for use as the Hillman City P-Patch through the City's P-Patch program. The application is:

- A. E23CT003S: Application of GROW, Inc. for property located at 4613 South Lucile Street, for open space purposes, 0.21 acres.

### 2. CAPITAL IMPROVEMENT PROGRAM

Does this legislation create, fund, or amend a CIP Project?  Yes  No

### 3. SUMMARY OF FINANCIAL IMPLICATIONS

Does this legislation have financial impacts to the City?  Yes  No

### 4. OTHER IMPLICATIONS

a. **Please describe how this legislation may affect any departments besides the originating department.**

No departments would be impacted by this legislation.

b. **Does this legislation affect a piece of property? If yes, please attach a map and explain any impacts on the property. Please attach any Environmental Impact Statements, Determinations of Non-Significance, or other reports generated for this property.**

This bill would effectuate the property tax reduction already approved by the King County Council for the property located at 4613 S Lucile St.

**c. Please describe any perceived implication for the principles of the Race and Social Justice Initiative.**

- i. How does this legislation impact vulnerable or historically disadvantaged communities? How did you arrive at this conclusion? In your response please consider impacts within City government (employees, internal programs) as well as in the broader community.**

The bill would marginally shift the tax burden from this property to all other properties in Seattle. The effect on any particular property would be minimal. Reducing the property tax burden for the Hillman City P-Patch would help to maintain this property as publicly-accessible open space over the long-term in a neighborhood that has a higher share of BIPOC residents than the citywide average.

- ii. Please attach any Racial Equity Toolkits or other racial equity analyses in the development and/or assessment of the legislation.**

Not applicable.

- iii. What is the Language Access Plan for any communications to the public?**

King County administers the PBRs and any Language Access Plan would be undertaken by the County.

**d. Climate Change Implications**

- i. Emissions: How is this legislation likely to increase or decrease carbon emissions in a material way? Please attach any studies or other materials that were used to inform this response.**

No anticipated impacts to carbon emissions.

- ii. Resiliency: Will the action(s) proposed by this legislation increase or decrease Seattle's resiliency (or ability to adapt) to climate change in a material way? If so, explain. If it is likely to decrease resiliency in a material way, describe what will or could be done to mitigate the effects.**

The property is being used for a P-Patch garden, which provides space for residents to grow food to support their households and communities, allowing those households to be more resilient. The PBRs is a County program that incentivizes property owners to maintain their property as open spaces long-term, particularly in rural and forested areas, helping to increase Washington's resiliency.

- e. If this legislation includes a new initiative or a major programmatic expansion: What are the specific long-term and measurable goal(s) of the program? How will this legislation help achieve the program's desired goal(s)? What mechanisms will be used to measure progress towards meeting those goals?**

Not applicable.

**5. CHECKLIST**

Please click the appropriate box if any of these questions apply to this legislation.

- Is a public hearing required? Yes.**

- Is publication of notice with *The Daily Journal of Commerce* and/or *The Seattle Times* required? Yes.**
- If this legislation changes spending and/or revenues for a fund, have you reviewed the relevant fund policies and determined that this legislation complies? N/A**
- Does this legislation create a non-utility CIP project that involves a shared financial commitment with a non-City partner agency or organization? N/A**

**6. ATTACHMENTS**

**List Summary Attachments (if any):**

None.

June 20, 2024

## MEMORANDUM

**To:** Parks, Public Utilities & Technology Committee  
**From:** Yolanda Ho, Supervising Analyst  
**Subject:** CB 120800: Application for Current Use Taxation for 2024

---

On June 26, the Parks, Public Utilities & Technology Committee (Committee) will hold a public hearing, discuss, and possibly vote on an application for current use taxation for the Hillman City P-Patch property owned by GROW, a non-profit organization that supports organic gardening and P-Patches. The application is:

E23CT003S: Application of GROW, Inc. for property located at 4613 S Lucile St, for open space purposes, 0.21 acres.

[Clerk File 322949](#) contains the application and the King County Department of Natural Resources and Parks (DNRP) report on the application. [Council Bill \(CB\) 120800](#) would approve the application as recommended by the DNRP report that is Attachment 1 to the legislation.

This memorandum describes: (1) Washington State's current use taxation program and King County's Public Benefit Rating System (PBRs); (2) the process for considering current use taxation applications; and (3) the Hillman City P-Patch application.

### Current Use Taxation

The Revised Code of Washington (RCW) Chapter [84.34](#) provides an incentive for property owners to voluntarily maintain open space on private land by taxing the property at a lower rate based on its current use, rather than the assessed value of its highest and best use. In King County, applications for current use taxation for open space are evaluated based on a "public benefit rating system" (PBRs) promulgated by King County pursuant to RCW 84.34.035.

Applications for PBRs open space designation are filed with and reviewed by the King County Department of Natural Resources and Parks (DNRP). DNRP assigns points to applications under the PBRs based on the type of open space resource a property is eligible for. Open space resources include: public recreation areas; buffers to public lands; linkages to pedestrian or bicycle trails; designated historic landmark sites; view corridors; urban open spaces; and significant plant, wildlife, or salmonid habitats. Bonus points are also provided for restoration of open space resources, conservation easements, and allowing public access to the open space.

For a property to be enrolled in PBRS, it must be eligible to receive at least five points to qualify. Open spaces with higher point totals receive larger reductions on property taxes, as shown in Exhibit 1 below.<sup>1</sup>

*Exhibit 1. Public benefit rating and property tax reduction*

<b>Public Benefit Rating</b>	<b>Property Tax Reduction</b>
0 to 4 points	0 percent
5 to 10 points	50 percent
11 to 15 points	60 percent
16 to 20 points	70 percent
21 to 34 points	80 percent
35 points and above	90 percent

Owners of property enrolled in the PBRS must maintain the open space in the same or better condition as it was when approved for enrollment. Property stays in the program until (1) its owner withdraws the property; (2) it is removed by DNRP because it no longer meets the PBRS criteria; or (3) a change of use occurs that results in the property being disqualified. When a property is removed, the landowner is required to pay the difference between the amount of tax paid as open space and the amount that would have been paid for up to a maximum seven years, plus interest and possibly a 20 percent penalty.

### **Council Action on Current Use Taxation Applications**

RCW 84.34.037 establishes the process to approve a current use taxation application, requiring that the legislative bodies for the County and City separately: (1) hold a public hearing; and (2) take legislative action to approve the application. While the respective legislative bodies may choose to approve the application in part or in whole, they must take the same action for the property to be enrolled in PBRS (i.e., if the City Council approves the application in whole, the County Council needs to do the same). The granting or denial of a current use taxation application is a legislative act and “is reviewable only for arbitrary and capricious decision-making.”

RCW 84.34.037 also provides guidance for evaluating applications for current use taxation. It includes factors such as fiscal impacts, environmental benefits, recreational opportunities, and adjacent uses. King County’s PBRS is designed to allow for a consistent rating of open spaces based on these factors.

---

<sup>1</sup> Only portions of property set aside for open space are eligible for property tax reductions. Buildings and improvements, such as parking areas or driveways, are excluded from the calculation of the property tax reduction.

## Hillman City P-Patch

The applicant (GROW) has applied for current use taxation for the Hillman City P-Patch located on the southeast corner of S Lucile St and 46<sup>th</sup> Ave S in the Hillman City neighborhood (Council District 2). The applicant has dedicated two lots totaling 9,270 square feet for P-Patch purposes, serving as publicly-accessible open space and community gardens. The lots flank a central lot owned by Seattle Parks and Recreation (see Exhibit 2). The west lot was enrolled in PBRs in 1999 and has a current use value set at 50 percent of assessed value. The east lot is not yet participating in the program.

GROW's application is to reclassify the west lot to add more PBRs categories, further lowering its taxable value, and to enroll the east lot in the program. The DNRP report on the application (Attachment 1 to CB 120800) describes the open space as follows:

The property is a community p-patch garden (known as the Hillman City P-Patch), and includes raised garden beds, walking paths and a shed used to store equipment used to maintain the gardens. The open space area consists of the entire property.

*Exhibit 2. Hillman City P-Patch Site*





DNRP recommended a total of 63 points under the PBRs:

- 5 points for the property's use as a public recreation area.
- 5 points for providing unlimited public access to the property.
- 18 points<sup>2</sup> for a conservation easement placed on the property, requiring it to be used for community garden and open space purposes. The City of Seattle's P-Patch program is the beneficiary of the easement, which was granted to the City in 2006.
- 35 points for the easement and access because the property provides both unlimited public access and that access is protected through an easement.

This would result in a current use value set at 10 percent of market value and a 90 percent reduction in taxable value for the portion of the land enrolled in PBRs. In 2023, the total appraised value for both parcels was \$538,000. Approval of the application would reduce the appraised value by 90 percent. Using the 2023 appraised value and property tax rate, this reduction would reduce the total taxable value to \$53,800, resulting in a property tax amount of \$437. The property tax due for both lots in 2023 was \$2,626, for reference.

Property taxes in Washington State are levied to raise a specified amount of revenue in a given year, and this amount is divided by the appraised value of all properties in Seattle. The reduction in the appraised value of properties participating in the PBRs does not decrease the total amount of revenue the City receives, but instead marginally increases the tax due from all other properties in Seattle. Participation in PBRs therefore shifts the resulting tax savings to landowners in affected levy rate distributions through an increase in levy rates, which essentially results in no loss of property tax. Thus, approval of this application would have no fiscal impact to the City.

The King County Hearing Examiner held a public hearing on the application on November 29, 2023, and recommended that the Metropolitan King County Council approve the application. On January 16, 2024, the County Council passed [Ordinance 19733](#) approving the application.

### **Next Steps**

The Committee will hold a public hearing, discuss, and may vote on CB 120800 at its June 26 meeting. Note that a vote the same day as a public hearing requires passage of a motion by the Committee Chair to suspend Council Rule VI.H.3.

If the Committee votes to make a recommendation on the bill on June 26, the City Council could vote on the bill as early as July 2. After Council passes the legislation, King County will incorporate the lower taxable values in its 2025 tax rolls.

cc: Ben Noble, Director  
Aly Pennucci, Deputy Director

---

<sup>2</sup> GROW used an old application form where the conservation easement bonus category provided 15 points, which would have resulted in a total of 60 points as indicated on its application. PBRs now grants applications with a conservation easement 18 points, resulting in the total of 63 points, as indicated in the DNRP report.



SEATTLE CITY COUNCIL  
**CENTRAL STAFF**

# **Current Use Taxation Application (2024)**

## **Council Bill 120800**

---

YOLANDA HO, LEGISLATIVE ANALYST

PARKS, PUBLIC UTILITIES & TECHNOLOGY COMMITTEE

JUNE 26, 2024

# Current Use Taxation Overview

---

- Reduces property taxes in exchange for long-term open space preservation, authorized by Revised Code of Washington (RCW) 84.34
- Open space, forest land, farmland, and landmarks are eligible
- King County Department of Natural Resources and Parks (DNRP) evaluates applications based on a “Public Benefit Rating System” (PBRs)
- Requires public hearings and approval from Metropolitan King County Council and Seattle City Council
- Shifts tax savings to other property owners (marginal increase) with no impact to total tax collections

# Hillman City P-Patch



# Hillman City P-Patch

---

- DNRP recommended 63 points under the PBRs for:
  - Public Recreation Area 5 points
  - Unlimited public access 5 points
  - Conservation easement or historic easement 18 points
  - Easement and access 35 points
- If approved, would result in 10% of market value and a 90% reduction in taxable value for the 0.21 acres enrolled
- County Council approved the application on January 16, 2024
- CB 120800 would approve the application, allowing it to receive the property tax reduction next year

# Questions?



Legislation Text

---

**File #:** Inf 2499, **Version:** 1

---

Ship Canal Water Quality Project Update



# Ship Canal Water Quality Project

Parks, Public Utilities & Technology Committee

*Budget Update – June 26, 2024*





# Agenda

1. Project and Budget Overview
2. Cost and Schedule Factors
3. Budget Details
4. Next Steps and Summary



Seattle  
Public  
Utilities



King County



- Reducing Seattle's combined sewer overflows
- Joint Project with King County
- Construction underway

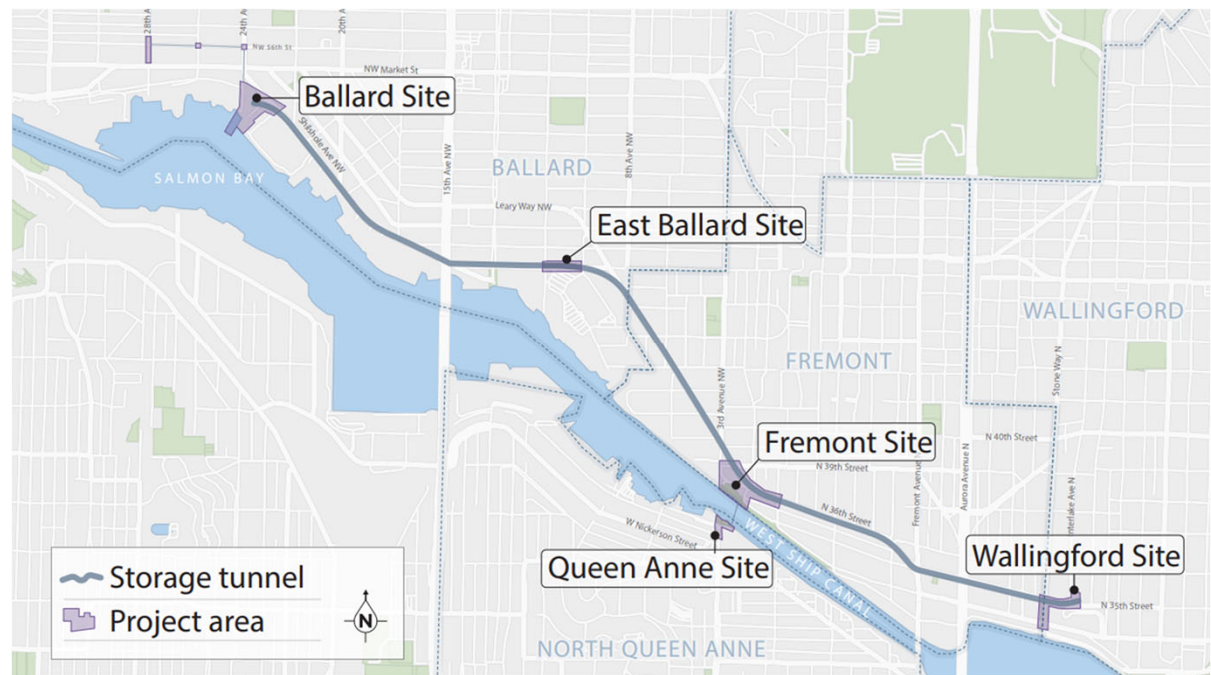

# 2013 Wastewater Consent Decree

- With US Department of Justice, US Environmental Protection Agency, and WA Department of Ecology
- Performance requirement:  
*Less than 1 overflow per outfall per year on a 20-year moving average*

## **SPU investments to reduce CSOs since 2008:**

- 4 major tank projects
- 2 major green stormwater projects
- 50 sewer system improvement projects

Plus the Ship Canal Water Quality Project and several green stormwater projects are under construction.



# Progress to Date

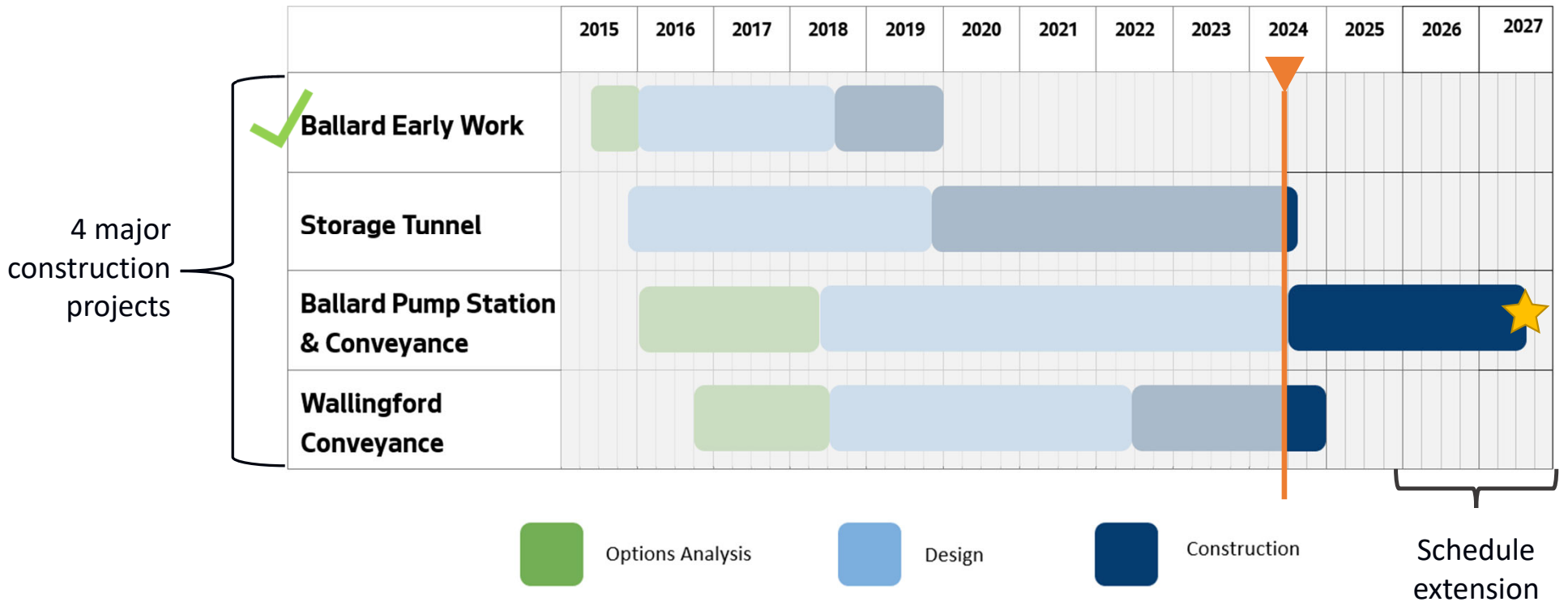

## Ballard Early Work

- Constructed permanent pier, power for tunneling, removed contaminated soil
- Total Project Cost: \$10M
- Completed in 2019



## Wallingford Conveyance

- Construction since 2023 of new conveyance pipes
- Total Project Cost Projection: \$19M
- **Will be completed this year**



## Storage Tunnel

- Construction since 2020 in 5 neighborhoods plus storage tunnel
- Total Cost Projection: \$335M
- **Will be completed this year**



# Ballard Conveyance and Pump Station

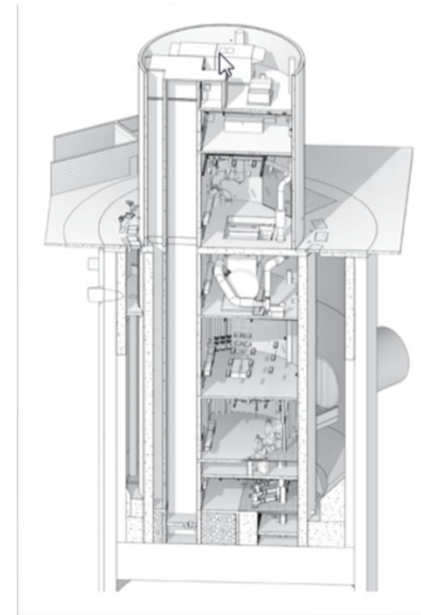
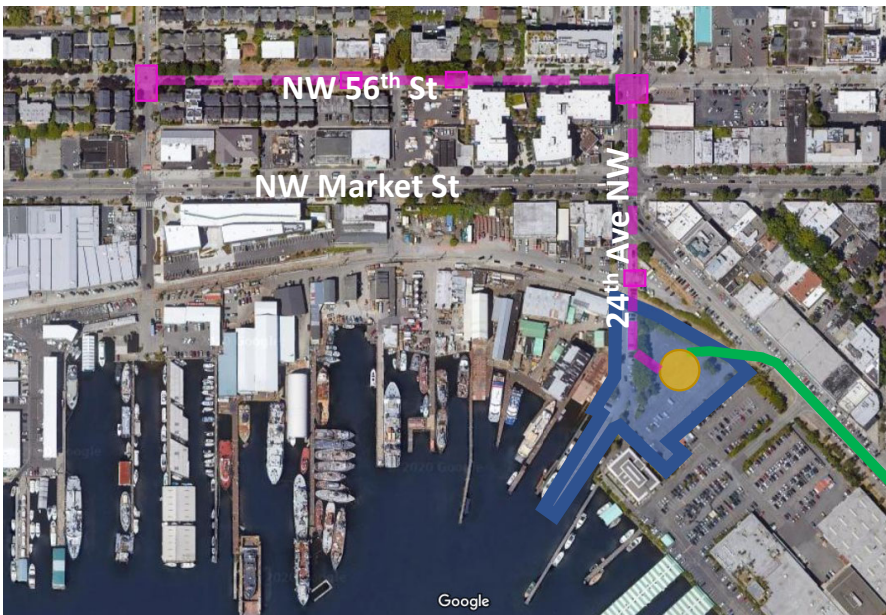

# 2024 Cost Estimate - Key Factors

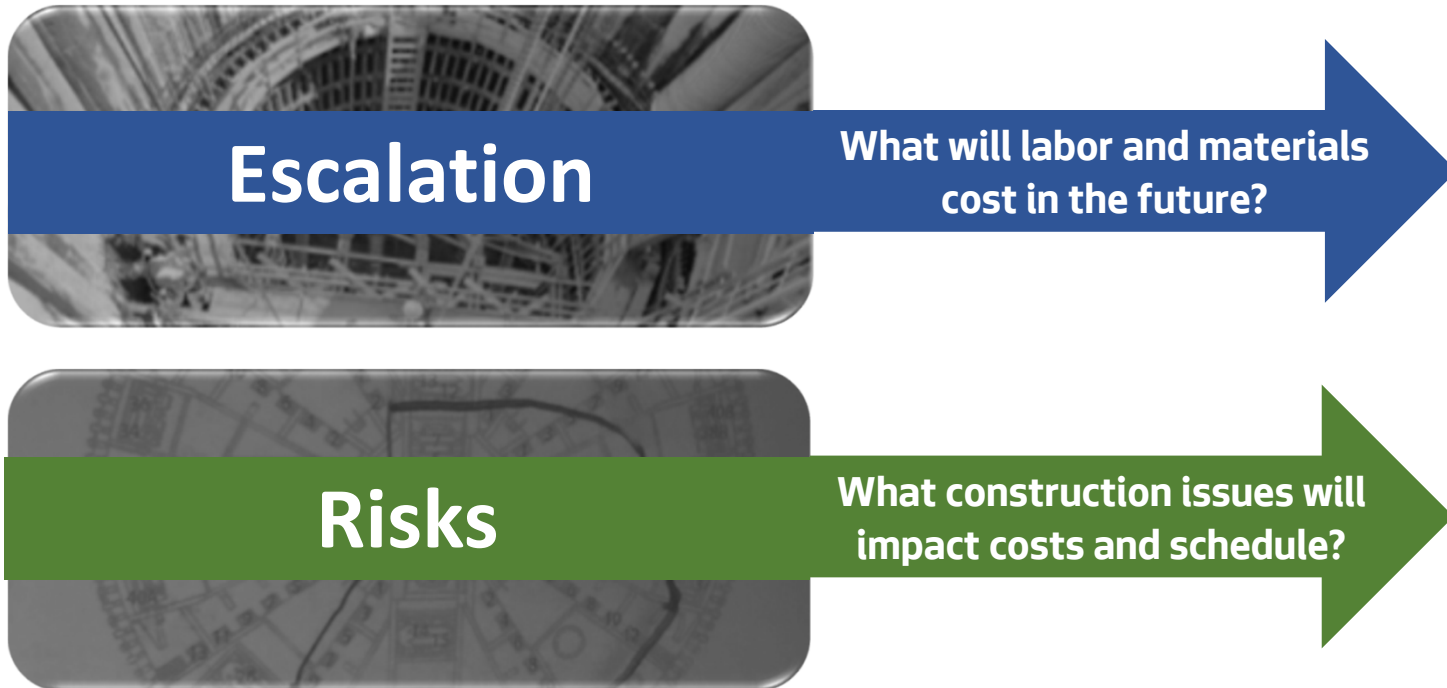

# Best Practices: Escalation Estimates, Risk & Cost Management

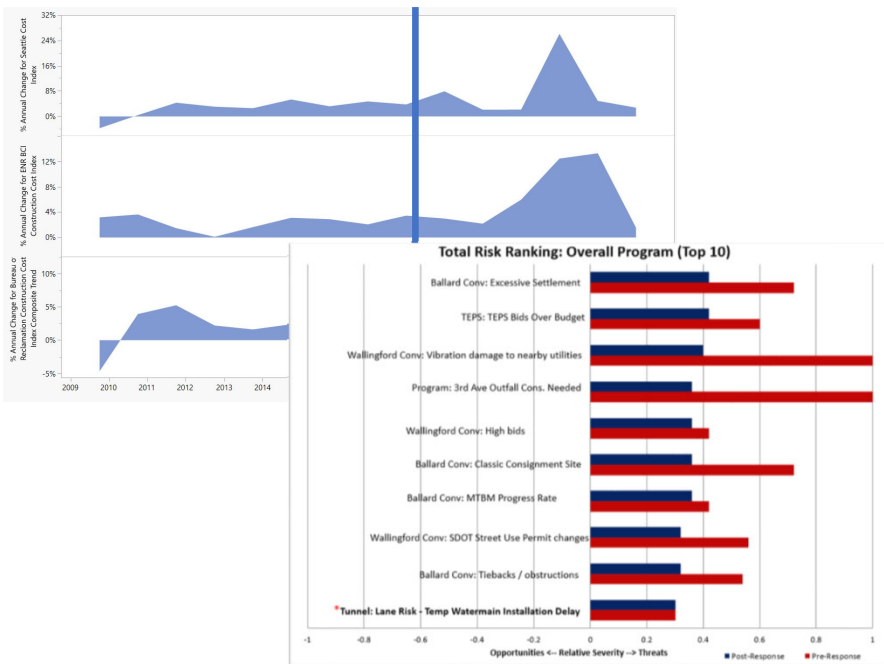

## Cost Management

1. Monthly reviews:
  - scope, schedules, and costs
  - risk registers and evaluation of budget confidence
2. Value engineering
3. Project cost reviews
4. Financing options





# Budget - Key Factors since 2018

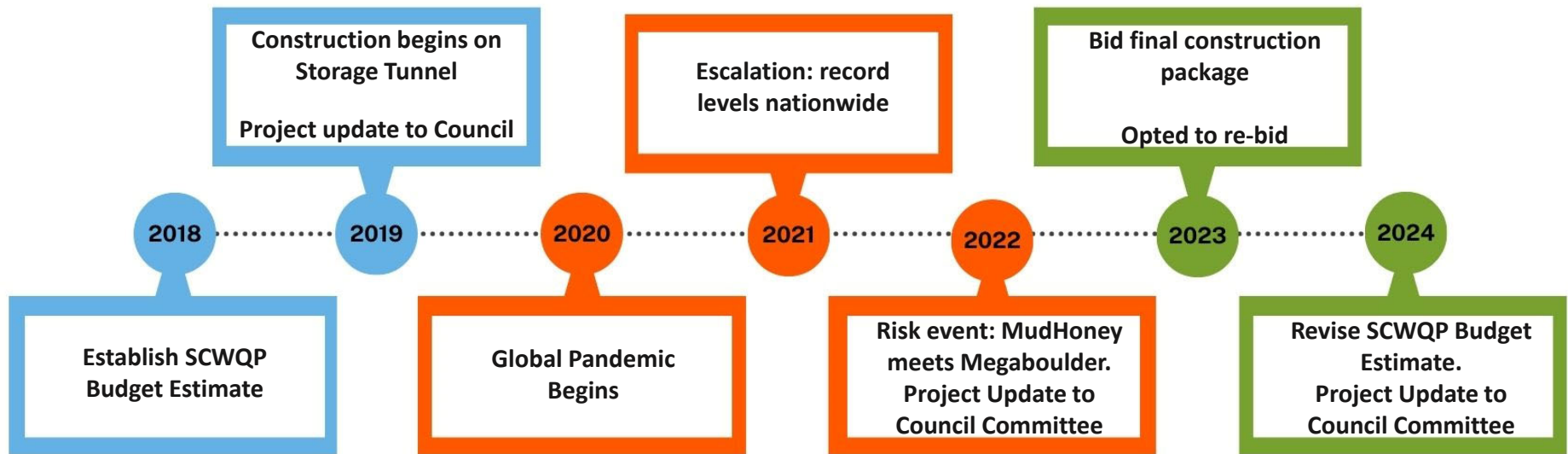

# Impact: Cumulative Escalation

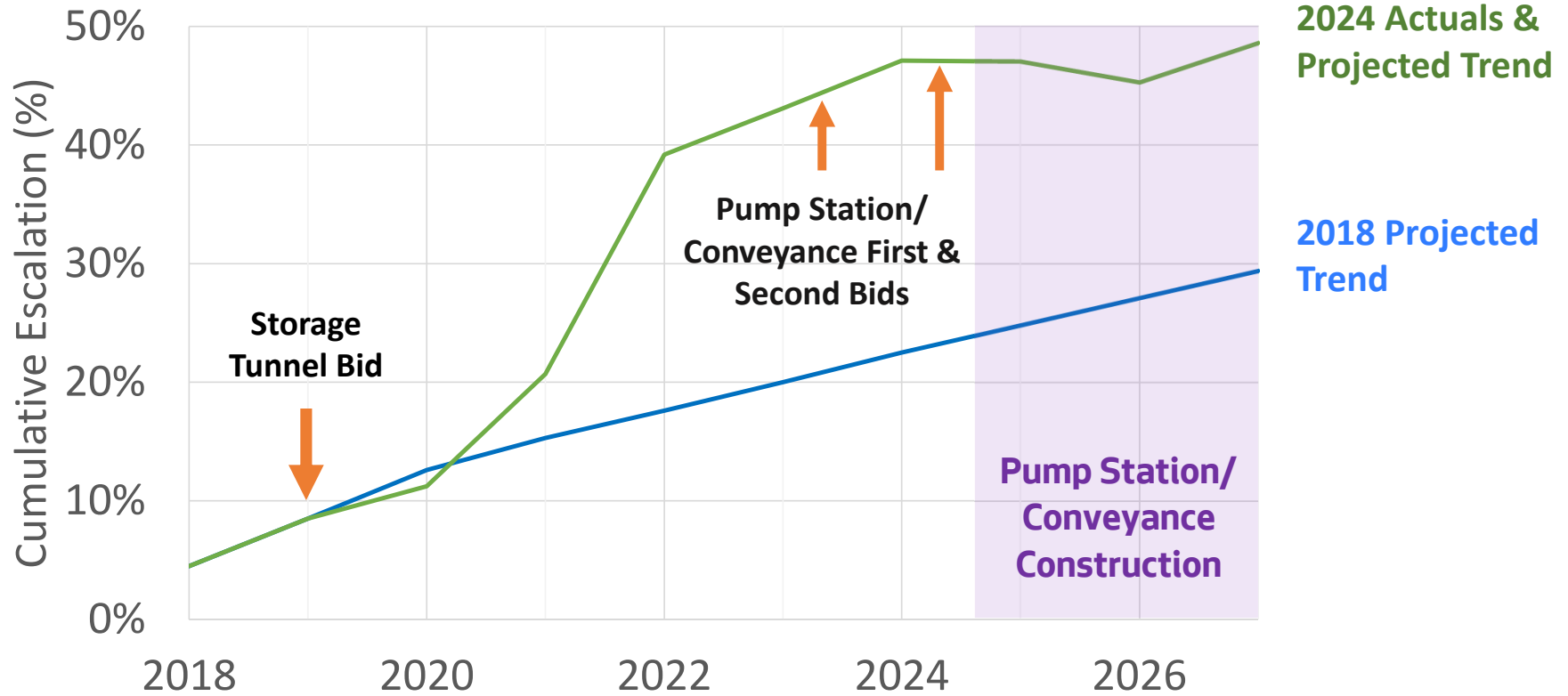

# Impact: Underground Risk Events

## A 12-foot diameter mega-boulder

- Risk register covered at 5% likelihood
- Contractor asserted damages of ~3.5 months, \$17M

## Inaccurate “As-built” records

- Underground infrastructure not per as-builts
- \$1.8M impact

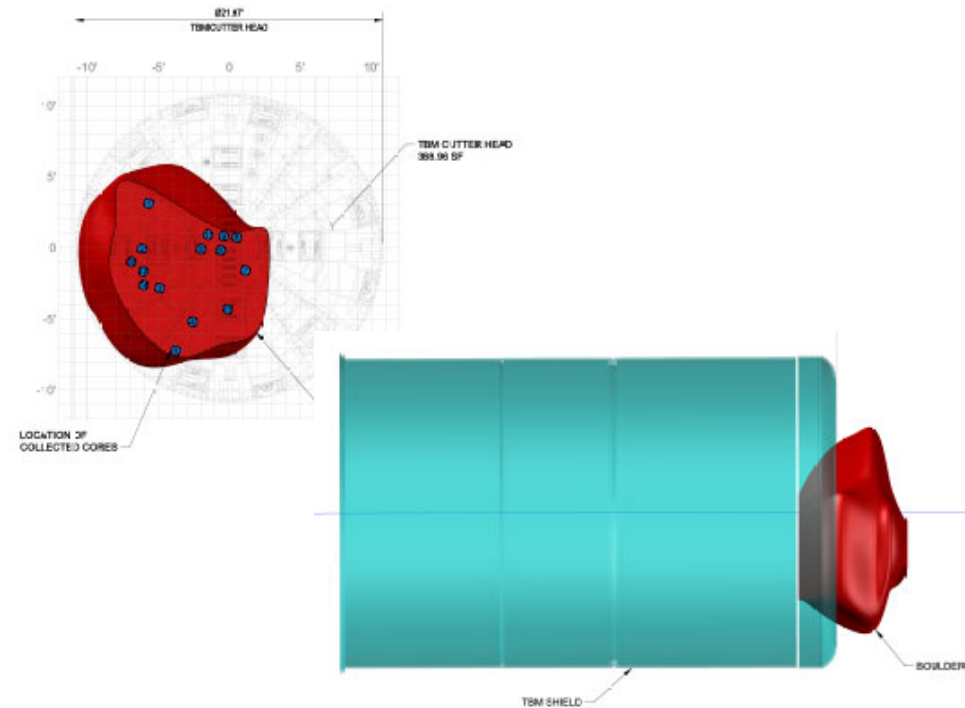

# Cost Management

SCWQP Action	Savings
3 major value engineering and cost reduction efforts	\$67M cost reductions
Over \$341M in low interest rates loans	\$267M across the life of the loans
Restructured and re-bid the Ballard Pump Station and Conveyance Construction Package	\$22M cost reduction



# 2024 Project Budget

**\$710 M**  
**80% confidence**

*SPU is committed to managing capital project budgets within the Strategic Business Plan rate path with no impact to the City's General Fund.*



# Budget Variance - \$570M to \$710M

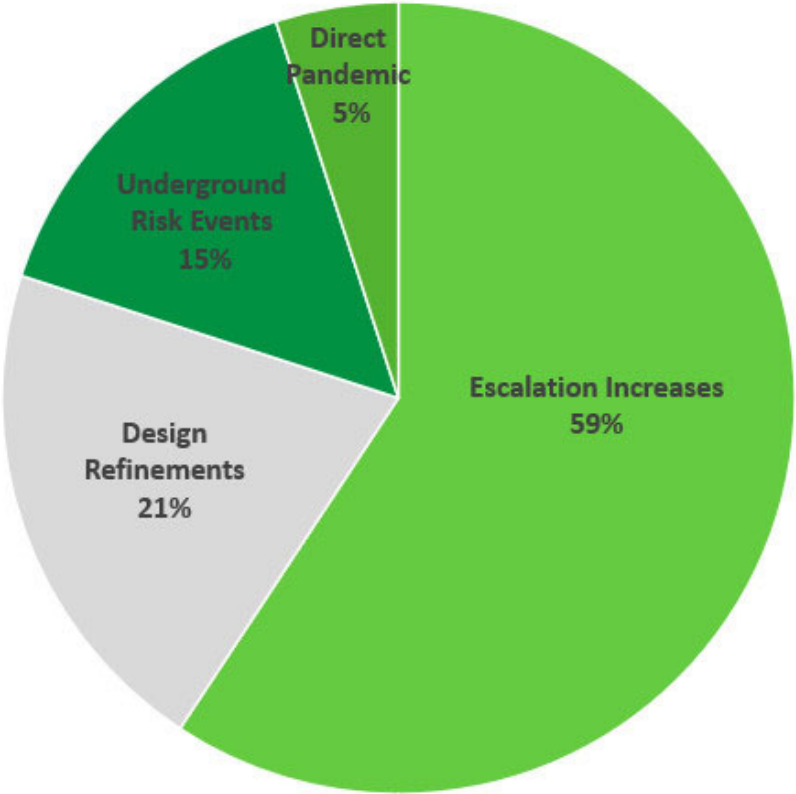

Design Refinement Category	Value
Design Refinement	\$15M
Scope Addition/Change	\$7M
Planning Estimate Corrections	\$3M

# Summary

- 2024 Project Budget: \$710M at 80% confidence
- Project Completion: 2027
- Project costs will be managed within the Strategic Business Plan rate path





Legislation Text

---

**File #:** Res 32136, **Version:** 1

---

**CITY OF SEATTLE**

**RESOLUTION \_\_\_\_\_**

A RESOLUTION relating to Seattle Public Utilities; adopting a 2025-2030 Strategic Business Plan for Seattle Public Utilities; and endorsing a three-year (2025-2027) rate path and a subsequent, three-year (2028-2030) rate forecast to support the Strategic Business Plan Update.

WHEREAS, Resolution 31534, approved by the City Council on August 11, 2014, adopted the Seattle Public Utilities (SPU) 2015-2020 Strategic Business Plan; and

WHEREAS, SPU's Strategic Business Plan establishes the utility's vision, mission, and strategic framework, and highlights utility initiatives and investments, and essential service delivery levels; and

WHEREAS, Resolution 31534 also directed SPU to review and update the Strategic Business Plan every three years, adding three years to the Strategic Business Plan and re-evaluating the three-year rate path and subsequent three-year rate forecast; and

WHEREAS, Resolution 31760, approved by the City Council on November 13, 2017, adopted SPU's 2018-2023 Strategic Business Plan Update; and

WHEREAS, Resolution 32000, approved by the City Council on May 10, 2021, adopted SPU's 2021-2026 Strategic Business Plan Update; and

WHEREAS, SPU completed a process to thoroughly review and revise its Strategic Business Plan covering the years 2025 through 2030; and

WHEREAS, that strategic planning update process included extensive collaboration with SPU's Customer Review Panel, employee engagement, and community outreach and research, including stakeholder meetings, business community interviews, non-English-speaking outreach, online surveys, and social media; and



WHEREAS, the resulting proposed 2025-2030 Strategic Business Plan contains an updated, three-year rate path and three-year rate forecast for water, drainage, wastewater, and solid waste rates developed by identifying, evaluating, and recommending reductions and priority additions to current utility expenditures, resulting in average rate increases of 4.7 percent per year for six years; and

WHEREAS, the City Council reviewed the proposed 2025-2030 Strategic Business Plan, the associated rate path and rate forecast, the recommendations of the Customer Review Panel, and the results of the community research and outreach; NOW, THEREFORE,

**BE IT RESOLVED BY THE CITY COUNCIL OF THE CITY OF SEATTLE, THE MAYOR  
CONCURRING, THAT:**

Section 1. The City Council adopts Seattle Public Utilities’ 2025-2030 Strategic Business Plan (“Plan”), a copy of which is included as Attachment 1 to this resolution and incorporated by reference.

Section 2. To achieve the goals of the Plan, the annual rates for Seattle Public Utilities’ lines of business are endorsed as indicated in the table below.

<b>Line of Business</b>	<b>2025</b>	<b>2026</b>	<b>2027</b>	<b>2028</b>	<b>2029</b>	<b>2030</b>	<b>Average</b>
Water	2.0%	2.0%	6.3%	3.3%	6.5%	3.8%	4.0%
Sewer	5.0%	5.0%	5.0%	6.2%	7.0%	5.1%	5.5%
Drainage	5.0%	5.0%	5.1%	6.6%	6.3%	7.2%	5.9%
Solid Waste	2.5%	3.1%	3.4%	3.4%	3.8%	2.5%	3.1%
<b>Combined</b>	<b>3.7%</b>	<b>3.9%</b>	<b>4.9%</b>	<b>5.0%</b>	<b>6.0%</b>	<b>4.6%</b>	<b>4.7%</b>

Section 3. Actual rate changes for each of Seattle Public Utilities’ lines of business are subject to approval by the City Council via rate ordinances.

Section 4. Seattle Public Utilities will complete an overall review and update the Plan every three years, adding three years to the Plan and re-evaluating the subsequent three-year rate path and three-year rate forecast. The next complete review and adjustment of the Plan will be completed in 2027 and encompass the years 2028 to 2033.

Section 5. Seattle Public Utilities will provide quarterly updates to the City Council to track progress in achieving the goals of the Plan.

Adopted by the City Council the \_\_\_\_\_ day of \_\_\_\_\_, 2024, and signed by me in open session in authentication of its adoption this \_\_\_\_\_ day of \_\_\_\_\_, 2024.

\_\_\_\_\_  
President \_\_\_\_\_ of the City Council

The Mayor concurred the \_\_\_\_\_ day of \_\_\_\_\_, 2024.

\_\_\_\_\_  
Bruce A. Harrell, Mayor

Filed by me this \_\_\_\_\_ day of \_\_\_\_\_, 2024.

\_\_\_\_\_  
Scheereen Dedman, City Clerk

(Seal)

Attachments:  
Attachment 1 - Seattle Public Utilities 2025-2030 Strategic Business Plan Update  
Appendix A - 2025-2030 Highlighted Initiatives and Investments Detail  
Appendix B - Community Research and Outreach Summary

Appendix C - Financial Forecast

Appendix D - Affordability and Accountability Overview

Appendix E - Customer Review Panel Comment Letter



## 2025-2030 Strategic Business Plan Update

## Contents

Our Message to You.....	2
About Seattle Public Utilities .....	3
Our Guiding Principles .....	4
Our Mission.....	5
Our Vision.....	5
Why We’re Updating Our Plan.....	5
Your Utility, Your Voice .....	6
Focus On: Delivering Equitable Essential Services.....	7
Focus On: Stewarding Environment and Health.....	10
Focus On: Empowering Our Customers, Community, and Employees.....	14
Focus On: Strengthening Our Utility’s Business Practices .....	17
About Rates.....	19
Keeping Rates Affordable .....	19
Factors Impacting Rates.....	19
Three-year Rate Path and Projection.....	21
Bill Impact .....	22
Where the Money Goes.....	23
Customer Financial Assistance.....	24
Customer Review Panel .....	255
Supporting Documents and Appendices.....	26

## Our Message to You

Our rapidly changing world brings heightened challenges to water and waste management. Rising temperatures and increased pollution are threatening our waters. Wildfires are commonplace. Annual flooding, like the Duwamish River overtopping, demands constant preparedness. Local salmon runs are the lowest in decades. When I moved to Seattle more than 20 years ago, nobody talked about wildfire smoke impacting our summers or the Duwamish River overtopping its banks. But today, these risks and others are frequent topics of conversation, and they are impacting our daily lives. This is particularly true for the most vulnerable in our city. Simply put - climate change and environmental pollution present major challenges for water, land, and waste management.

I want you to know Seattle Public Utilities is rising to meet these challenges. We are committed to protecting and regenerating our environmental resources, safeguarding and enhancing our built infrastructure, and investing in our communities—particularly in those that are most vulnerable. As we face a changing world, we remain dedicated to delivering life-sustaining services for you.

- We are working 24/7 to ensure the delivery of water, waste, and customer assistance to Seattle residents and businesses;
- We are protecting almost 100,000 acres of mountain watershed against pollution and wildfire to provide safe and reliable drinking water to 1.6 million people;
- We are building massive underground tunnels to reduce sewage overflows into local water bodies by over 89%;
- We are investing in green stormwater infrastructure and urban tree canopy to naturally treat 820 million gallons of polluted stormwater each year;
- We are partnering to clean up contaminated sediment in the Duwamish River, benefitting environmental justice communities like South Park and Georgetown;
- We are forging public-private partnerships to build a more circular economy by preventing food waste from entering landfills and supporting reuse networks; and
- We are moving upstream to reduce waste and pollution by developing new legislation that requires the companies that produce goods and materials to design for less waste and pay for the cost of product recycling or disposal.

SPU's vision is simple: **Community Centered, One Water, Zero Waste**. We are committed to putting you at the center of what we do and being at the forefront of addressing essential service delivery, climate change, environmental pollution, and inequity. This Strategic Business Plan Update is the guiding document to help us get there.

We are honored to partner with you to build a future where waste is reduced, precious water resources are valued, and communities benefit.

Sincerely,

Andrew Lee  
General Manager / CEO  
Seattle Public Utilities

## About Seattle Public Utilities

Every day, SPU delivers essential, life-sustaining water and waste services while protecting public health and our environment to ensure healthy, thriving communities. About 1,450 SPU employees, including our vital front-line workforce, work tirelessly together to deliver reliable and efficient utility services to 1.6 million people in the greater Seattle area. Our services include:



### **Drinking Water**

We deliver safe and clean drinking water from our protected mountain watersheds to your home and work.



### **Garbage, Recycling, and Composting**

We provide collection and disposal services, as well as programs to reduce waste.



### **Sewer**

We protect public health and the environment by taking dirty water out of your home and waterways.



### **Drainage**

We manage stormwater to keep our waterways clean and prevent flooding.



### **Clean City Programs**

We remove litter, graffiti, needles, dumped materials, and other hazards to keep Seattle clean and safe.



### **Customer Service, Information, and Engagement**

We provide information and financial assistance, address any issues, and help our customers and community.

## Our Guiding Principles

Guided by our shared values, we work every day to put our customers and communities at the center of all we do. We are committed to working together to uphold our CARES principles:

<b>Customers and Community</b>	<i>We strive to understand and respond to customer and community needs—inside and outside our organization.</i>
<b>Affordability and Accountability</b>	<i>We do our best to ensure utility services are available to everyone regardless of ability to pay, and we responsibly manage and value every ratepayer dollar.</i>
<b>Risk and Resilience</b>	<i>We seek to minimize utility risks, reduce our environmental footprint, and improve our community’s capacity to adapt to change in the face of hardship.</i>
<b>Equity and Empowerment</b>	<i>We work to dismantle institutional racism by building trusting relationships, prioritizing equity and inclusion in decision-making, and creating opportunities for all. This includes listening to and investing in our people—the valued employees of Seattle Public Utilities.</i>
<b>Service and Safety</b>	<i>We focus on delivering high-quality, reliable, and sustainable services and infrastructure that prioritize the health and safety of our employees and our community.</i>



## Our Mission

Seattle Public Utilities fosters healthy people, environment, and economies by partnering with our community to equitably manage water and waste resources for today and for future generations.

## Our Vision

Our bold vision reflects SPU's goals for the next 50 years of service, infrastructure investment, and management of water and waste. We will lead with equity and work in partnership with communities and employees to create a just and sustainable future for all people and for our planet. We understand that the actions we take today have the power to transform our employees, community, environment, and economy for generations to come.

### COMMUNITY CENTERED

*SPU puts YOU at the center of all we do.* We put people at the heart of our work and work with them to understand and address their priorities. We seek to better understand and address employee, customer, and community needs, and build the long-lasting, equitable, and inclusive relationships necessary to address these needs. SPU strives to live by this inclusive principle and embed it in all we do.

### ONE WATER

*Water is essential for life.* Our health, wealth, and livelihoods depend on it, and we must protect it for future generations. One Water means we value and carefully manage water in all its forms: through conservation, storage, restoration, and reuse. Whether it is fresh water or wastewater, all water is protected and managed in an integrated and sustainable way, and all people and species have access to healthy waters.

### ZERO WASTE

*All materials have value, and we strive to waste nothing.* We must look at the whole life cycle of materials so we can eliminate waste, prevent pollution, encourage product durability and reusability, conserve natural resources, and ultimately build a circular and inclusive economy. Zero Waste protects health and the environment through the conservation of all resources from production through consumption without burning or pollution to land, water, or air.

## Why We're Updating Our Plan

SPU's Strategic Business Plan (SBP) helps us focus our work to better meet the needs of our customers and communities. It builds on our strengths and guides our essential service delivery and comprehensive business strategy. It also provides our customers with a predictable three-year rate path and projections for the subsequent three years.

We update the SBP every three years to allow for future uncertainties and adjustments. This update reinforces commitments made in our original plan, reflects on our progress over the last three years, responds to factors influencing our work, and informs our rate path.

## Your Utility, Your Voice

At SPU, we recognize that the heart of our service mission lies in the communities we serve. Guided by customer feedback, we strive to provide clean water, manage waste responsibly, and uphold our commitment to the environment while maintaining accessible services for all. Our engagement and research efforts ensure that your voice directly informs our path forward.

The following complementary research and public engagement activities informed this update:

**Voice of the Customer Research:** We reviewed 15 research studies commissioned by SPU and others from 2020-2023 to understand the experiences, opinions, and perspectives of residential and commercial customers and SPU employees. These studies captured feedback on a wide range of topics and customer perspectives.

**Community Outreach:** We engaged communities across Seattle to center and amplify the voices of historically underrepresented groups to ensure we can address the needs of the diverse communities we serve. Seattle Department of Neighborhoods Community Liaisons facilitated focus groups and connected with communities citywide through events and a concise multilingual survey to collect feedback on our services.

**Qualitative Research:** In our commitment to inclusive engagement, this research prioritized intentional outreach to often underrepresented populations. SPU facilitated a series of online discussion boards to gain a deeper understanding of customer perceptions and insights regarding SPU services.

**Online Customer Survey:** To better understand the needs of our residential customers, we conducted a scientifically valid online survey. We gathered 1,042 responses and gained critical insights regarding customer opinions, preferences, and knowledge. The survey stands as a new baseline enabling SPU to track and analyze customer trends in the future.

**Customer Review Panel and Community Advisory Committees:** The Customer Review Panel and Community Advisory Committees play a crucial role in shaping our services. These groups offer regular input on the Strategic Business Plan and assess our ongoing efforts in community engagement and plan implementation to ensure that SPU remains aligned with the communities we serve.

### What We Learned

1. Customers are generally satisfied with SPU's services and view them as essential. However, there is an opportunity to fill a gap in awareness of the full range of services provided by SPU.
2. Affordability stands as a top concern for both residential and business customers. Continued outreach and education on available assistance programs are necessary.
3. There is room for continued growth in engaging and communicating with non-native English speakers.

## Focus On: Delivering Equitable Essential Services

We deliver the essential services our customers and community rely on every day for healthy living. Our staff works year-round to deliver reliable water, drainage and wastewater, solid waste, and Clean City services. We prioritize community needs, lead with equity, remove barriers, and partner with others to ensure equitable access to these essential services.

### Goals

- Provide reliable, quality services that meet requirements and commitments.
- Make equitable investments to improve services for underserved and over-burdened communities.

### Strategies and Highlights

Focus On: Delivering Equitable Essential Services	
<b>Strategy</b>	<b>Provide resources and facilities and remove barriers to ensure frontline service delivery staff can be successful.</b>
<b>Initiatives and Investments Highlights</b>	<p> <b>North “One Water” Operations Facility</b>            The North Operations Center and Haller Lake facilities are emergency-critical SPU workforce facilities. Located outside of known seismic, flood, and landslide-hazard zones, these facilities have the potential to remain functional and support sustained, in-person operations within 24 hours of an earthquake emergency. Currently, these facilities are out-of-date and do not meet current seismic code requirements. They also require significant updates to meet frontline workforce needs. This investment will replace both facilities with a ‘One Water’ operations complex in North Seattle that supports the Drainage and Wastewater and Water lines of business. This multi-benefit investment addresses a significant need and positions the utility to better support our workforce and customers through more resilient facilities.</p> <p><b>In-House Water Quality Treatment</b>            SPU’s Tolt and Cedar River Treatment Facilities are vital to providing safe, clean drinking water for customers and meeting regulatory requirements. To ensure continuity of service, SPU will take over operations of both facilities when current Design-Build-Operate (DBO) contracts expire in 2025 (Tolt) and 2029 (Cedar River). Taking over operations, maintenance, and management of these facilities is a major undertaking that will expand our internal capabilities and increase resilience.</p>

	<p>Field Engineering Improvements Program</p> <p>To improve the delivery of operable Drainage and Wastewater projects, SPU will hire senior engineers to provide O&amp;M expertise and support to project teams. These engineers will be embedded with frontline crews to better understand and represent their work, provide quick turnaround on design solutions and real-time help to resolve problems in the field, support crews as they respond to emergency or special projects, and represent O&amp;M needs on capital projects.</p>
<p><b>Strategy</b></p>	<p>Prioritize and support equitable access to essential services.</p>
<p><b>Initiatives and Investments Highlights</b></p>	<p>SPU Support Services for the Unsheltered</p> <p>SPU’s RV Wastewater Pump Out Program protects our water quality and benefits members of Seattle’s unhoused populations who live in RVs with little access to pump-out facilities. Without pump-out facilities, these RVs dump waste in drainage basins, streets, or adjacent properties. SPU’s RV Wastewater Pump Out Program has already reduced RV-related spill responses by 72% since 2019 and is planned to continue. The program’s success allows our Spill Response Team to focus on other environmental compliance priorities like cleaning, business inspections, and spill prevention.</p> <p>SPU’s purple bag program, which collected over 1.5 million pounds of litter from encampments in 2023, will also continue to provide support services for those who are unsheltered.</p> <hr/> <p> Duwamish Valley Resilience</p> <p>Sea level rise and changing rain patterns are exacerbating flood risk in several Seattle neighborhoods, particularly impacting low-lying areas that have sustained decades of underinvestment and industrial pollution. These risks are especially acute in South Park and Georgetown. SPU’s investment in Duwamish Valley Resilience, in partnership with other City departments, is a comprehensive approach to improving flood mitigation, water quality, and community resilience and creating better health outcomes today and in the future. To support this work, SPU will leverage significant Drainage and Wastewater infrastructure investments and develop external funding partnerships. We are also working in partnership with a community advisory group comprised of representatives from industrial businesses, residential communities, and community-based organizations.</p>

**2021-2023 Accomplishments**

**South Park Flooding Investments and Response:** Finished construction of a new pump station and drainage conveyance partnership project serving the South Park neighborhood, installed sewer backup prevention equipment in flood-prone homes, and developed an emergency response plan to address tidal flooding.

**Clean City and Unsheltered Services:** Removed 3 million pounds of illegally dumped material and 850,000 square feet of illegal graffiti per year. Provided essential services to support unsheltered populations and promote public health, collecting over 400,000 sharps, performing 1,500 RV pump-out services, and removing up to 1.2 million pounds of trash from encampments annually to address health, hygiene, and environmental needs.

**Pandemic Service Delivery:** Navigated pandemic challenges to successfully provide more than 21 million reliable residential garbage, recycling, and compost pickups and up to 45 billion gallons of clean and safe drinking water per year.

**Regulatory Compliance:** Met drinking water quality and water pollution regulatory requirements every quarter to ensure public health and safety, environmental protection, a vibrant local economy, and social equity outcomes.

**Safety:** Implemented a new safety management system for effective incident reporting and management. Updated SPU's Workplace Violence Prevention Program, including situational awareness and de-escalation trainings.

### *Environmental Justice at SPU*

SPU defines environmental justice as removing disparities for communities and employees who are disproportionately affected by underinvestment, pollution, climate change and health risks.

We seek to be a government partner that co-creates environmental solutions and strengthens communities by *centering racial equity*, sharing power, and prioritizing the experiences of those most impacted by SPU policies and practices.

We envision a Seattle where communities can thrive with access to nature, safe water, sustainable waste services, and related jobs.

We commit to:

- Developing **community relationships with** BIPOC and low-income communities so that they are leading and guiding environmental justice decisions that benefit all.
- Protecting and prioritizing **healthy environments and services** for community members and employees. SPU is committed to prioritizing the safety and well-being of frontline employees.
- Investing in a **green economy**, economic justice, access to affordable utilities, multi-benefit investments, and building intergenerational wealth.
- Preparing for **climate resilience** so communities are ready for the impacts of climate change.

## Focus On: Stewarding Environment and Health

Communities thrive when the environment is healthy and supported by the equitable stewardship of water, land, and waste resources. Unfortunately, our region’s natural resources are under threat from pollution, diseases, climate change, loss of habitat, ocean acidification, overconsumption, and excessive waste, threatening sustainability, affordability, and our quality of life.

SPU is the Pacific Northwest’s largest utility responsible for managing most forms of pollution, waste, wastewater, litter, illegal dumping, spills, and graffiti. We take this responsibility seriously and are committed to restoring and maintaining a healthy environment. We collaborate with partners to build resilient ecosystems and circular economies and embrace nature-based, science-informed approaches to managing water and land resources.

The success of our work depends on equitable actions and stewardship. We will continue to do our work in beneficial, fair, and just ways, and we will incentivize green technology and innovations to improve human and environmental health outcomes for all.

### Goals

- Develop One Water resilience from our watersheds, to cities, to the Sound.
- Advance the zero waste circular economy.

### *Adapting to a Warmer Planet: SPU’s Climate Resilience Action Plan*



Climate change is an urgent challenge. It amplifies environmental risks and vulnerabilities, particularly for communities affected by historic and current inequities and regional salmon recovery efforts. In addition to reducing greenhouse gas emissions, SPU is preparing for the impacts of climate change by increasing system and community resilience. For example, we’re integrating climate guidance into capital project design, operations, and management decisions to help staff understand future climate impacts and better consider adaptation strategies.



Other initiatives and investments in SPU’s Climate Resilience Action Plan focus on resilient workforce facilities, watershed ecosystem stewardship, long-term water supply planning, salmon recovery, and flood mitigation in underinvested areas.



Look for this icon to find climate resilience investments and initiatives throughout this document.

## Strategies and Highlights

Focus On: Stewarding Environment and Health	
Strategy	Invest in strategic plans, projects, and programs that advance a holistic One Water approach.
Initiatives and Investments Highlights	 Shape Our Water – Citywide and Focus Area Drainage and Wastewater Planning SPU’s Shape Our Water plan is an integrated citywide plan for the next 50 years of drainage and wastewater investments in Seattle. This initiative will address a gap in resources to develop area plans and engage community in parallel to Shape Our Water in specific, high-priority areas, such as: <ul style="list-style-type: none"> <li>• neighborhoods prioritized for planning and investment by other departments and agencies,</li> <li>• neighborhoods with inadequate sewer or drainage systems that will be experiencing significant growth, and</li> <li>• neighborhoods with a history of underinvestment.</li> </ul>
	 Water Supply Planning for the Next 50 Years This initiative renews SPU’s commitment to incorporate climate change, uncertainty, and adaptive management into our water supply planning efforts. 2023-2029 water supply projects like a Climate Change Hydrology Analysis, Supply Alternatives Analysis, and the Cedar Falls Long Range Plan will inform our next Water System Plan to ensure sufficient water for people and fish today and for the next 50 years.
Strategy	Advance nature-based and community-centered climate adaptations and solutions.
Initiatives and Investments Highlights	 Cedar and Tolt Watershed Resilience Climate change and associated threats of reduced snowpack, drought, extreme precipitation events, and wildfires have the potential to impact watershed ecosystems, water supply, and drinking water quality. This initiative aims to increase resilience in Seattle’s municipal watershed by addressing watershed protection, wildfire risk management, forest ecosystem management, monitoring, and continuous improvement.

Strategy	Reduce materials use and prevent water and carbon pollution.
Initiatives and Investments Highlights	 <p>Upstream Legislative Strategies to Reduce Pollution and Waste          SPU is working with federal, state, and regional governments to advance ‘upstream’ measures that prevent toxic chemicals, hazardous materials, and excessive waste from ending up in the waste stream and negatively impacting human health and the environment. Examples include supporting legislation that holds producers financially responsible for using toxic chemicals in their products and for hazardous or excessive product disposal, and securing funding to remove toxic chemicals from historic and ongoing sources.</p>
	 <p>2030 Carbon Neutrality and Sustainable Operations          SPU aims to be carbon neutral by 2030 and resource efficient in our operations while actively exploring opportunities to generate renewable energy and support other sustainability-related innovations. This initiative includes the development and implementation of renewable energy, green purchasing, and electrification strategies, as well as projects and programs that drive resource conservation in operations.</p>
	 <p>Waste Prevention and Diversion          SPU is pursuing opportunities that continue progress made to divert solid waste from disposal and enhance waste prevention. These include:</p> <ul style="list-style-type: none"> <li>• food waste reduction and compliance enforcement to prevent food waste from being landfilled,</li> <li>• Reuse Seattle reusable food service ware initiative,</li> <li>• Waste Prevention Strategic Plan implementation and measurement, and</li> <li>• bolstering the local circular economy through building material reclamation and reuse.</li> </ul>

### 2021-2023 Accomplishments

**Shape Our Water Vision Plan:** Produced a national award-winning Community Vision that will guide our plan to improve the performance and resilience of our drainage and wastewater systems while optimizing social and environmental benefits for the city. Completed a comprehensive analysis of citywide drainage, wastewater, and receiving water challenges and opportunities, and published an interactive StoryMap explaining how water has shaped our city and how investments in infrastructure can benefit communities and enhance equity.

**Ship Canal Water Quality Project Tunneling:** Continued Ship Canal Water Quality Project construction with over \$230 million in projects, including the completion of a 2.7-mile, 30-million-gallon storage tunnel to handle current and future impacts of climate change on Seattle’s stormwater systems.

**Solid Waste Plan Update:** Adopted SPU’s Moving Upstream to Zero Waste plan, which prioritizes waste prevention through the whole lifecycle of materials to eliminate waste and toxins, divert material from



landfills, prevent pollution, reduce carbon emissions, conserve natural resources as early as possible, and invest in the circular economy.

**Carbon Emission Inventories:** Completed 2019-2021 carbon emissions inventories for SPU operations and set up a process to provide annual emissions reporting. Inventories showed that emissions generated through the utility's day-to-day operations declined from 16.6 thousand metric tons in 2019, to 14.3 thousand metric tons in 2021. Worked with King County as part of the Puget Sound Regional Emissions Analysis to establish a consumption-based emissions inventory for Seattle.

**Reuse Seattle:** Supported music and entertainment venues, cafes, institutions, and public schools in implementing reusable food service ware through the Reuse Seattle initiative.

## Focus On: Empowering Our Customers, Community, and Employees

We partner with customers, community, and staff to identify and refine our utility’s priorities and approaches. Collaboration helps us build a more just, livable, and resilient Seattle. At the heart of this work is SPU’s commitment to equity and empowerment – leading with race and social justice, building trust and relationships, and elevating the voices of customers, community, and employees. We will continue to prioritize environmental justice, focus on diverse community input, and foster better workplace opportunities and culture.

### Goals

- Build trusted relationships, partnerships, and allyships with our customers and communities.
- Be an anchor institution that advances equity, addresses environmental justice, and partners to leverage holistic community benefits in all we do.
- Invest in all our employees.

### Strategies and Highlights

Focus On: Empowering Our Customers, Community, and Employees	
<b>Strategy</b>	<b>Provide utility assistance that makes a difference.</b>
<b>Initiatives and Investments Highlights</b>	<p><b>Customer Affordability Programs</b></p> <p>SPU will continue to improve programs, procedures, and policies that help keep our services affordable for lower-income customers, help customers pay their bills on time, and prevent water shutoffs related to nonpayment. As part of this work, SPU is partnering with Seattle City Light on a holistic evaluation of our utility bill assistance programs to inform future program improvements.</p>
	<p><b>Side Sewer Assistance Program</b></p> <p>SPU’s pilot Side Sewer Assistance Program, launched in 2022, provides no-interest loans to low-income homeowners in need of urgent side sewer repairs. We are also developing incentives for side sewer preventative maintenance services such as inspection and cleaning. This initiative will scale up the Side Sewer Assistance Program and focus on improving system capacity issues by lining or repairing leaky side sewers.</p>

Strategy	Empower and support customers to make sustainable behavioral changes.
Initiatives and Investments Highlights	<p>Advanced Metering Infrastructure Planning</p> <p>SPU is in the planning and readiness phase of an Advanced Metering Infrastructure (AMI) project. When implemented, SPU’s AMI investment will replace the manual meter reading system with an electronic wirelessly transmitting system. AMI will enable automated meter reading, reduce carbon emissions, improve billing accuracy, enable customers to detect water leaks, and promote conservation by providing customers with real time visibility into their daily water consumption.</p>
Strategy	Lead with race and social justice in delivering equitable engagement, capacity building, investment outcomes, and opportunities.
Initiatives and Investments Highlights	<p> Seeds of Resilience Impact Investment Fund</p> <p>This investment aims to advance equity, economic growth, and environmentally sustainable waste and water management activities in the private and nonprofit sectors. The program identifies SPU business needs and engages with business and nonprofit partners to help us generate desired outcomes, center equity in the design of the project, and measure outcomes.</p> <hr/> <p>Equity in Contracting</p> <p>By engaging women- and minority-owned businesses (WMBE) firms to learn about barriers to entry for City contracting opportunities, this initiative aims to develop strategies to improve access to opportunities for WMBE firms and enhance the overall experience of doing business with the City.</p>
Strategy	Foster a more equitable workplace, work culture, and better work opportunities.
Initiatives and Investments Highlights	<p>Employee Life Cycle Initiatives</p> <p>To create a workplace culture that promotes equity and inclusion, SPU is examining the employee life cycle from when an employee first applies through their departure from SPU. Initiatives and policy development include employee onboarding experience, workforce development, succession planning, and the offboarding experience. The initiatives will build on the successes SPU has had in creating a diverse workforce and creating professional growth opportunities through training, mentorship, and career advancement.</p>

### 2021-2023 Accomplishments

**Pandemic Customer Affordability Assistance:** Dispersed nearly \$5 million in Federal and State pandemic assistance funds and took innovative steps to avoid shutoffs and provide flexible payment plans to customers having difficulties paying utility bills.

**Employee Survey:** Engaged SPU employees through an annual survey to gather feedback and provide a strategy to improve SPU’s work environment. The 2023 survey had a 67% response rate, with an overall 68% favorability rating and increased overall supervisor and team scores. Results show SPU staff placing increasing importance on diversity, equity, and inclusion.

**Record Hiring and Diversity Improvements:** Restarted the SPU apprenticeship program and made improvements in workforce recruitment, learning and development, and employee retention. Processed up to 600 hires, internships, promotions and temporary-to-regular position changes each year, and increased promotions of BIPOC employees by 150% (from 21 to 51) between 2020 and 2023.

**Seeds of Resilience Innovation Investments:** Identified multiple projects to build water resiliency, encourage a circular economy, and grow blue-green job opportunities for BIPOC communities. Projects included installing a new water bottle refill station in downtown Seattle and training formerly incarcerated people to deconstruct houses for reuse of materials.

**Women- and Minority-Owned Business Enterprise Contracting/Procurement Results:** Increased equity in SPU contracting to exceed participation levels of 23% (purchasing) and 25% (consulting) contract dollars and become a model of success for the City.

## Focus On: Strengthening Our Utility’s Business Practices

Our customers expect their faucets to flow, toilets to flush, and garbage to be picked up. These services are delivered under increasingly complex and costly regulations and via aging infrastructure that must be resilient in the face of earthquakes, climate change, and other challenges. SPU continues to examine its business practices and assess ways to improve service, be more efficient, provide value, and enhance affordability and accountability. We use the best available science, data, and analysis to inform utility decision-making and performance.

### Goals

- Enhance ratepayer affordability and utility accountability.
- Manage assets and risks optimally.
- Foster a culture of shared leadership, continuous improvement, and innovation.

### Strategies and Highlights

Focus On: Strengthening Our Utility’s Business Practices	
Strategy	Deliver on high-impact affordability and accountability commitments.
Initiatives and Investments Highlights	Alternative Funding and Financing SPU works to keep rates affordable through the pursuit of alternative funding and financing sources, strategic partnerships with agencies and funders, and coordination with other City departments. SPU will continue to develop and refine structures and strategies to ensure that this work is robust, impactful, and efficient.
Strategy	Address aging, undersized, and at-risk facilities and infrastructure to ensure continuous service delivery.
Initiatives and Investments Highlights	 Drainage and Wastewater Asset Management Program A significant amount of SPU’s sewer pipes need to be replaced or rehabilitated due to age. Pipe relining (a type of rehabilitation) is a more affordable and sustainable way to reduce system risks and improve resiliency and can be up to 10 times less expensive than full pipeline replacement. SPU will develop an in-house pipe relining team as another cost-effective option to respond to urgent needs.

	 <p><b>Water Asset Management and Seismic Program</b>          SPU owns and operates a regional water system of assets including dams, treatment plants, transmission and distributions pipes, storage tanks, pump stations, and more. Many assets are aging. This initiative continues critical investments in repair, rehabilitation, and replacement of these assets. This initiative also includes continued implementation of SPU’s strategy to increase SPU’s resilience against earthquakes.</p>
<p><b>Strategy</b></p>	<p>Support a culture of continuous improvement and innovation.</p>
<p><b>Initiatives and Investments Highlights</b></p>	<p><b>Strategic Technology Plan</b>          With the growth of technologies across industries, SPU is developing a strategic plan to improve aspects of technology including data management, business processes, and governance. Our goal is to provide the most sustainable, accessible, efficient, and valuable services for our customers and employees. This plan will develop a guide for our future to align with changing business plans and goals in how technology is operated, maintained, and decided upon within SPU’s technology portfolio.</p>

### 2021-2023 Accomplishments

**Alternative funding and financing:** Successfully pursued and leveraged a wide variety of alternative funding and financing sources such as Federal and State appropriations, King County Flood Control district funding, philanthropic support, and Water Infrastructure Finance and Innovation Act and State Revolving Fund loans (including over \$340M in low-interest loans for the Ship Canal Water Quality Program, which results in a net \$260M savings to ratepayers vs. traditional bond funding).

**Big ideas:** Provided \$70,000 to fund 10 employee proposals to improve SPU service delivery, including field operation QR codes for information access, field staff multi-media training materials, and a hands-on exhibit for community outreach.

**Asset management:** Managed SPU’s extensive infrastructure system, including rehabilitating 8 wastewater pump stations and 8 drainage facilities, lining 19 miles of sewer pipe, and completing nearly 1400 sewer pipe work orders to reduce system risks and improve resiliency.

**Covid financial management:** Worked through the complexities of pandemic funding and finances, including a roughly 400% increase in customer payment delinquencies between 2020 and 2022, while maintaining a positive financial outlook, bond ratings, and financial policies.

**Capital project delivery results:** Increased the speed and efficiency of planning and delivering capital improvement projects, such as the Ship Canal Water Quality Project Tunnel, while maximizing community value.

## About Rates

A key element of our strategic business plan is balancing forward-looking improvements with the thoughtful use of ratepayer revenue.

SPU's rates are structured to collect only the amount of revenue needed to support business operations and financial obligations while responding to regulatory requirements and preparing for future challenges.

Customers pay for essential services, infrastructure, and day-to-day operations through their utility rates. Our rates assume that the current level of operations and maintenance, as well as efforts to improve and find efficiencies in that work, will continue and that SPU is also responding to the needs of the future.

## Keeping Rates Affordable

As a responsible steward of ratepayer dollars, SPU works diligently to reduce costs, increase productivity and efficiency, invest in assets that have multiple benefits, and remove barriers to service access. This includes leveraging alternative sources of funding and financing, identifying efficiencies in capital project delivery, and managing infrastructure assets in a way that balances short- and long-term risk with cost and public benefit.

## Factors Impacting Rates

To deliver value, enhance affordability, and demonstrate accountability, SPU develops rates by evaluating operating costs, capital investment needs, long-term risks, debt repayment, service demands, financial policies, and anticipated revenue associated with service delivery.

We aim to limit the increase in the cost of services by:

- replacing aged infrastructure to avoid costly failures,
- implementing continuous improvement and innovation initiatives to reduce waste,
- automating processes and introducing new technology to increase efficiencies,
- improving capital infrastructure planning to better reflect probable investments,
- using cash balances to smooth rate changes,
- negotiating lower solid waste contract rates, and
- reducing the cost of borrowing money.

However, several factors can increase costs and offsetting savings. These include inflation, regulatory compliance, aging infrastructure, increased interest rates, and increasing contractual obligations.

Chart 1 (see next page) explains what drives SPU's projected rate path by showing expenses by category.

**Chart 1: SPU Expenses by Category (2025, percentages)**

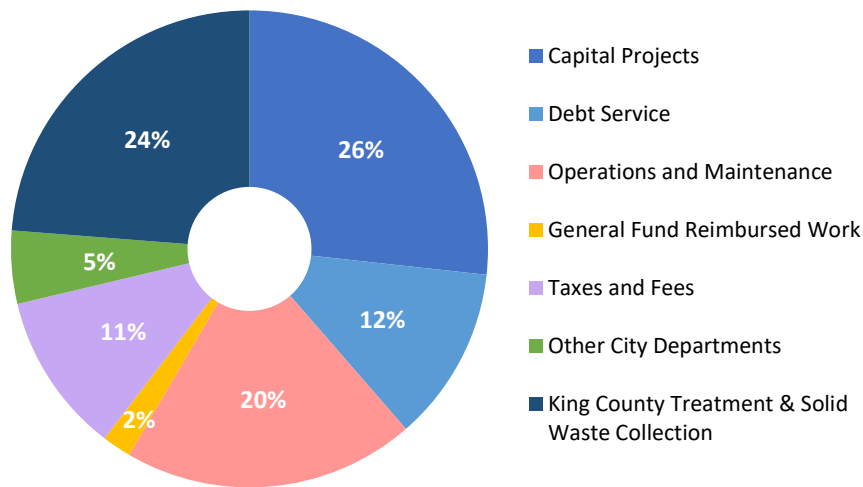

Capital costs and related debt service account for 39 percent of the budget. Major service contracts, including King County wastewater treatment, account for 24 percent; and taxes, fees, and costs paid by SPU to other City departments make up 16 percent. Utility operations, which include work required to deliver essential services, work on behalf of the City’s General Fund, and work that is reimbursed by other departments, make up 22 percent.

Chart 2 further explains expenses by showing costs for 2023. The total 2023 annual budget is \$1.4 billion. Fixed (non-discretionary) costs and capital improvement program (CIP) costs make up 77 percent of the budget (or \$1.1 billion for 2023).

**Chart 2: SPU Expenses by Category (2023, \$ millions)**

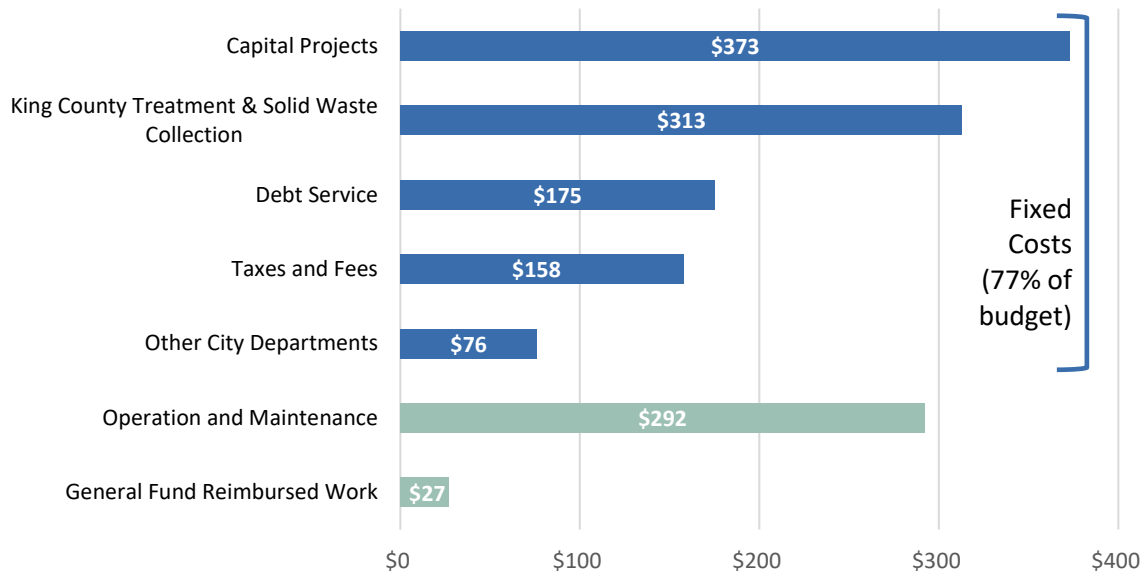



## Three-year Rate Path and Projection

SPU’s six-year rate path is updated every three years. The projected average annual rate increase for 2025-2030 is 4.7 percent, up from 4.2 percent in 2021-2026.

The rise in the annual rate increase is based on several factors:

- Higher than expected increases in King County wastewater treatment charges to Seattle;
- Increasing operational expenses due to inflation; and
- Increasing capital expenses related to state and federal regulatory compliance, aging infrastructure, and increased interest rates.

Table 1 describes the projected three-year rate path and projected three-year rate forecast for the six-year period, by line of business and combined.

*Table 1: 2025-2030 Average Rate Increases*

	<b>Rate Path</b>			<b>Rate Forecast</b>			<b>Average</b>
	2025	2026	2027	2028	2029	2030	
Water	2.0%	2.0%	6.3%	3.3%	6.5%	3.8%	<b>4.0%</b>
Sewer	5.0%	5.0%	5.0%	6.2%	7.0%	5.1%	<b>5.5%</b>
Drainage	5.0%	5.0%	5.1%	6.6%	6.3%	7.2%	<b>5.9%</b>
Solid Waste	2.5%	3.1%	3.4%	3.4%	3.8%	2.5%	<b>3.1%</b>
<b>Combined</b>	<b>3.7%</b>	<b>3.9%</b>	<b>4.9%</b>	<b>5.0%</b>	<b>6.0%</b>	<b>4.6%</b>	<b>4.7%</b>

### *Understanding King County Wastewater Rate Increases*

Seattle and 33 other regional utilities send their wastewater to King County’s regional wastewater system for treatment, before it flows out to Puget Sound. Major capital projects related to renewing and replacing old infrastructure and complying with environmental regulations have resulted in significant cost increases for King County Wastewater. King County’s sewer treatment rates are projected to increase annually from 5.75% to 7.0% by 2030. Because King County relies on revenues from local sewer agencies to finance its operations, SPU and 33 other regional utilities are facing substantial sewer fee rate increases. SPU is working to minimize the impact of rate increases on customers while ensuring our region fulfills its environmental responsibilities and keeps our local waters clean.

## Bill Impact

Tables 2-4 show typical monthly costs for several different types of customers. (SPU bills customers every two months.)

SPU recognizes the impact of rate increases on our customers and communities. We take affordability seriously and work hard to minimize impact by keeping increases as low as possible, ensuring rates are predictable, and providing financial assistance for those who need it.

**Table 2: Typical Monthly Costs for Single Family Home**

	<b>2025</b>	<b>2026</b>	<b>2027</b>	<b>2028</b>	<b>2029</b>	<b>2030</b>
Water	\$50	\$51	\$54	\$56	\$60	\$62
Sewer	\$83	\$87	\$92	\$97	\$104	\$109
Drainage*	\$63	\$66	\$69	\$74	\$78	\$84
Solid Waste	\$60	\$62	\$64	\$66	\$68	\$70
<b>Combined</b>	<b>\$256</b>	<b>\$266</b>	<b>\$279</b>	<b>\$293</b>	<b>\$310</b>	<b>\$325</b>
<b>Monthly Change</b>	<b>\$11</b>	<b>\$10</b>	<b>\$13</b>	<b>\$14</b>	<b>\$17</b>	<b>\$15</b>

**Table 3: Typical Monthly Costs for Multifamily Unit (Apartment Building)**

	<b>2025</b>	<b>2026</b>	<b>2027</b>	<b>2028</b>	<b>2029</b>	<b>2030</b>
Water	\$28	\$28	\$30	\$31	\$33	\$34
Sewer	\$77	\$81	\$85	\$90	\$96	\$101
Drainage*	\$12	\$12	\$13	\$14	\$15	\$16
Solid Waste	\$30	\$31	\$32	\$34	\$35	\$36
<b>Combined</b>	<b>\$147</b>	<b>\$153</b>	<b>\$160</b>	<b>\$169</b>	<b>\$179</b>	<b>\$187</b>
<b>Monthly Change</b>	<b>\$5</b>	<b>\$6</b>	<b>\$8</b>	<b>\$8</b>	<b>\$10</b>	<b>\$8</b>

**Table 4: Typical Monthly Costs for a Convenience Store**

	<b>2025</b>	<b>2026</b>	<b>2027</b>	<b>2028</b>	<b>2029</b>	<b>2030</b>
Water	\$122	\$125	\$133	\$137	\$146	\$152
Sewer	\$384	\$404	\$424	\$450	\$482	\$506
Drainage*	\$152	\$160	\$168	\$179	\$191	\$204
Solid Waste	\$604	\$623	\$644	\$666	\$692	\$709
<b>Combined</b>	<b>\$1,263</b>	<b>\$1,312</b>	<b>\$1,369</b>	<b>\$1,433</b>	<b>\$1,510</b>	<b>\$1,571</b>
<b>Monthly Change</b>	<b>\$44</b>	<b>\$49</b>	<b>\$58</b>	<b>\$64</b>	<b>\$77</b>	<b>\$61</b>

\* Drainage charges are billed to customers on their King County property tax statements.

Residential and commercial customers each account for approximately 95 percent of the rate revenue across all three utility funds. The remaining 5 percent comes from wholesale customers, including other cities and districts.

### Where the Money Goes

Chart 3 shows how the monthly costs are spent across utility expense areas, for a typical single family home customer paying \$256 per month through bi-monthly utility bills plus the drainage assessment on their annual property tax bill.

**Chart 3: Typical Customer Costs Breakout (2025)**



\$60.15	\$80.30	\$37.57	\$77.98
CAPITAL FINANCING	OPERATIONS & MAINTENANCE	TAXES & FEES	KING COUNTY TREATMENT/ SOLID WASTE COLLECTIONS
23%	31%	15%	30%

## Customer Financial Assistance

Our customers should have access to essential services regardless of their financial situation. This is why our affordability and accountability commitments are so important. Through this work, we aim to keep rate increases as low as possible and reduce potential hardship for our customers. We also offer bill assistance and programs to help customers save money, including:

- **Conservation and education programs** that help customers understand how their usage affects their bills and identify ways to potentially reduce them;
- The **Utility Discount Program**, which provides ongoing bill assistance to income-qualified customers;
- The **Emergency Assistance Program**, which provides credits to reduce past-due balances for income-qualified customers facing financial hardship;
- **Payment plans** that provide customers with flexibility in payments timed to fit their needs; and
- SPU's **Community Donation Fund**, which allows for voluntary contributions to help those in need.

SPU has been actively promoting these programs to ensure people know help is available when needed. To ensure we are meeting community needs, we are working with other City departments and community partners to remove barriers and improve the effectiveness of our affordability programs. To date we have:

- Worked proactively with low-income customers and small businesses;
- Increased Utility Discount Program enrollment through a self-certification pilot;
- Improved the Emergency Assistance Program and shut-off prevention and notification; and
- Created more flexible payment arrangements.

### *Reduce Consumption, Reduce Costs*

Customers who decrease their water usage or reduce their waste can save money on their bills. For instance, customers might reduce costs by taking shorter showers and switching to smaller garbage bins by recycling and composting more. We also offer rebates for installing cisterns and rain gardens that capture rainwater for irrigation, prevent pollution from entering our waterways, and contribute to flood prevention.

## Customer Review Panel

SPU’s Customer Review Panel provides advice and recommendations on the utility’s strategic plan and rates to the Mayor and City Council. The panel includes representatives from private, public, and nonprofit sectors, utility experts, business leaders, and community representatives. The panel regularly met with SPU leaders and provided valuable input that shaped this plan update.

### Panel

Suzanne M. Burke

Bobby Coleman

Ebony Rose Frazier

Gretchen Glaub

Raj Kumar

Noel Miller, Chair

Maria McDaniel

Amanda Richer, Vice-Chair

Robin Schwartz

Tiffany Sevilla

Miki Sodos

## Supporting Documents and Appendices

The 2025-2030 Strategic Business Plan Update and supporting materials are available at:  
[seattle.gov/utilities/about/plans/strategic-business-plan](https://seattle.gov/utilities/about/plans/strategic-business-plan).

### Appendices

- A. 2025-2030 Highlighted Initiatives and Investments Detail
- B. Community Research and Outreach Summary
- C. Financial Forecast
- D. Affordability and Accountability Overview
- E. Customer Review Panel Letter

**Appendix A - 2025-2030 Highlighted Initiatives and Investments Detail**

Focus Area	Effort	Type	Line of Business				Rate Impact		
			Water	Drainage & Wastewater	Solid Waste	All	Continued Base Funding	Increased Funding	New Investment
Delivering Equitable Essential Services	<a href="#">1. North 'One Water' Operations Facility</a>	Investment	✓	✓			✓	✓	
	<a href="#">2. In House Water Quality Treatment</a>	Investment	✓				✓	✓	
	<a href="#">3. Field Engineering Improvements Program</a>	Initiative				✓	✓		✓
	<a href="#">4. SPU Support Services for the Unsheltered</a>	Investment		✓	✓		✓		
	<a href="#">5. Duwamish Valley Resilience</a>	Investment		✓			✓	✓	
Stewarding Environment and Health	<a href="#">6. Shape Our Water – Citywide Focus Area Drainage and Wastewater Planning</a>	Initiative		✓			✓		
	<a href="#">7. Water Supply Planning for the Next 50 Years</a>	Initiative	✓				✓		
	<a href="#">8. Cedar and Tolt Watershed Resilience</a>	Initiative	✓				✓		
	<a href="#">9. Upstream Legislative Strategies to Reduce Pollution and Waste</a>	Initiative				✓	✓		
	<a href="#">10. 2030 Carbon Neutrality and Sustainable Operations</a>	Initiative				✓	✓		✓
	<a href="#">11. Waste Prevention and Diversion</a>	Investment			✓		✓	✓	
Empowering Customers, Community, and Employees	<a href="#">12. Customer Affordability Programs</a>	Initiative				✓	✓		
	<a href="#">13. Side Sewer Assistance Program</a>	Investment		✓			✓		✓
	<a href="#">14. Advanced Metering Infrastructure Planning</a>	Investment	✓						✓
	<a href="#">15. Seeds of Resilience Impact Investment Fund</a>	Initiative				✓	✓		
	<a href="#">16. Equity in Contracting</a>	Initiative				✓	✓		
	<a href="#">17. Employee Life Cycle Initiatives</a>	Initiative				✓	✓		✓
Strengthening Our Business Practices	<a href="#">18. Alternative Funding and Financing</a>	Initiative				✓	✓		
	<a href="#">19. Drainage and Wastewater Asset Management Program</a>	Investment		✓			✓		✓
	<a href="#">20. Water Asset Management and Seismic Program</a>	Investment	✓				✓		✓
	<a href="#">21. Strategic Technology Plan</a>	Investment				✓	✓		

## About

'Highlighted Initiatives and Investments' are representative examples of how SPU will advance the strategies described in the Strategic Business Plan. Initiatives represent policy, planning, and program work and generally require less significant expenditures (under \$5M). Investments result in tangible infrastructure, asset, asset repair, or service and require more significant investment (over \$5M).

Initiatives and investments represent a mix of continued base rate funding as well as new funding or increased investments. All initiatives and investments are funded through SPU rates except for SPU's support services for the unsheltered investment which is primarily funded by City of Seattle general fund dollars as part of the Clean City program. SPU's drainage and wastewater asset management work, water asset management and seismic work reflect multipart investments that will be reported on individually within the context of a broader program.



## SPU 2025-2030 Strategic Business Plan Investments and Initiatives Summary

(All budget estimates are for the six-year period 2025-2030)

Focus On: Delivering Equitable Essential Services		
<b>North “One Water” Operations Facility</b>	\$73.1m	Replace the North Operations Center and Haller Lake facilities with a new “One Water” operations complex.
<b>In-House Water Quality Treatment</b>	\$132.1m	SPU to take over operations of the Tolt and Cedar River drinking water treatment facilities.
<b>Field Engineering Improvements Program</b>	\$3.4m	Hire three senior engineers to be embedded in field service teams.
<b>SPU Support Services for the Unsheltered</b>	\$21.9m	Continue providing encampment trash-removal (with City general funds) and RV wastewater pump-out services.
<b>Duwamish Valley Resilience</b>	\$197.8m	Comprehensive partnerships to improve flood mitigation, water quality and community resilience, and health in the Duwamish Valley.

Focus On: Stewarding Environment and Health		
<b>Shape Our Water – Citywide and Focus Area Drainage and Wastewater Planning</b>	\$3.2m	Develop drainage and wastewater area plans for neighborhoods with inadequate infrastructure or a history of underinvestment.
<b>Water Supply Planning for the Next 50 Years</b>	(no additional budget need identified)	Assess and plan for water supply needs for the next 50 years.
<b>Cedar and Tolt Watershed Resilience</b>	(no additional budget need identified)	Protect Seattle’s source supply watersheds through wildfire risk management, watershed protection measures, and forest management.
<b>Upstream Legislative Strategies to Reduce Pollution and Waste</b>	(no additional budget need identified)	Work with federal, state, and regional governments to reduce and prevent toxic/hazardous materials and excess waste from impacting human health.
<b>2030 Carbon Neutrality and Sustainable Operations</b>	\$2.7m	Implement sustainability innovations and conservation improvements in SPU operations and facilities.
<b>Waste Prevention and Diversion</b>	\$9.9m	Implement five waste prevention and reuse programs to progress toward our Zero Waste goal.

Focus On: Empowering Customers, Community, and Employees		
<b>Customer Affordability Programs</b>	(no additional budget need identified)	Continue Utility Discount, emergency financial assistance, payment flexibility, and shutoff prevention programs to keep SPU services affordable and available to lower-income customers.
<b>Side Sewer Assistance Program</b>	\$10.4m	Continue providing 0% interest loans to low-income customers in need of urgent side-sewer repairs, adding incentives for maintenance and pipe lining.
<b>Advanced Metering Infrastructure Planning</b>	\$750k	Plan for the replacement of aging mechanical water meters with electronic, automated meters that can be monitored remotely.
<b>Seeds of Resilience Impact Investment Fund</b>	\$3.6m	Foster growth of small enterprises to meet business needs of SPU.
<b>Equity in Contracting</b>	(no additional budget need identified)	Engage WMBE firms to improve access to contracting opportunities.
<b>Employee Life Cycle Initiatives</b>	\$2.4m	Promote equity and inclusion throughout all phases of the employee experience.

Focus On: Strengthening Our Business Practices		
<b>Alternative Funding and Financing</b>	(no additional budget need identified)	Improve SPU's ability to leverage external funding and partnerships.
<b>Drainage and Wastewater Asset Management Program</b>	\$14.1m	Reline aging sewer pipes to extend life and improve resiliency of drainage and wastewater infrastructure.
<b>Water Asset Management and Seismic Program</b>	\$395.1m	Replace aging water mains and water service lines and complete seismic upgrades of water storage and distribution facilities.
<b>Strategic Technology Plan</b>	\$105m	Implement technology solutions to improve system operations efficiency, sustainability, cybersecurity, and customer responsiveness.

## 1. North 'One Water' Operations Facility

<b>SBP Focus Area</b>	Delivering Equitable Essential Services
<b>SBP Goals</b>	Invest in our employees
<b>SBP Strategy</b>	Foster a More Equitable Workplace, Work Culture, and Better Work Opportunities
<b>Type</b>	Investment
<b>SPU Branch/LOB</b>	DWW and Water
<b>Executive Sponsor</b>	Ellen Stewart and Alex Chen
<b>Project Manager/Lead</b>	TBD
<b>Reporting Cadence</b>	Quarterly
<b>Funding</b>	50/50 split between DWW and Water funds
<b>Last Update</b>	May 2023

### Part 1. Summary of the Investment

The North Operations Center and Haller Lake facilities are emergency-critical SPU workforce facilities. Located outside of known seismic, flood, and landslide-hazard zones, these facilities have the potential to remain functional and support sustained, in-person operations within 24 hours of an earthquake emergency. Currently, these facilities are out-of-date and require significant updates to meet frontline workforce needs.

This investment replaces both facilities with a 'One Water' operations complex in North Seattle that supports the Drainage and Wastewater and Water lines of business. This multi-benefit investment addresses a significant need and positions the utility to better support our workforce and customers through more resilient facilities.

### Part 2. Targeted Commitments and Performance Measures

It is expected that a new operations complex will take approximately 10 years to complete. In the 2025-30 business planning period, the project is expected to move through land acquisition, pre-design, design, and begin construction.

### Part 3. Financial Summary

The costs summarized are based on a total desired cost of \$120M for the 2024-2033 program. The preferred alternative has not been identified and costs may range from as low as \$120M to as high as \$170M. This scenario is a placeholder for phasing estimation with a breakdown of about \$30M for land acquisition, \$64M in hard/construction costs, and \$26M in soft costs.

<b>Program Title</b>	<b>SPU Workforce Facilities Investments (\$000's)</b>
----------------------	---

Project Name	DWW and Water “One Water” North Ops Facility						
	2025	2026	2027	2028	2029	2030	TOTAL
Baseline O&M	n/a	n/a	n/a	n/a	n/a	n/a	n/a
Baseline Capital	800	600	2,150	7,000	2,500	n/a	13,050
Additional Capital needed	11,800	9,800	8,250	12,850	8,675	8,675	60,050
<b>Total</b>	<b>12,600</b>	<b>10,400</b>	<b>10,400</b>	<b>19,850</b>	<b>11,175</b>	<b>8,675</b>	<b>73,100</b>

**Part 4. Capacity Plan to Deliver (Existing/Capital Only)**

SPU has a proposed position in the 2024 budget intended to lead the implementation of the Workforce Facilities Master Plan update. This position will move forward with land acquisition and assembling a project team in early 2024.

**Part 5. Racial Equity Impact**

SPU's workforce facilities investments reflect the Utility's commitment to support its workforce equitably, reduce its environmental impact, and enhance the communities SPU serves.

**Part 6. Climate and Sustainability Impact**

For facilities planning purposes, a frontline worker is defined as someone who must physically report to work at an SPU-operated facility. Climate change impacts are experienced acutely by frontline workers, such as more severe weather events, increasingly stressed infrastructure, and worsening summer heat and wildfire smoke. SPU is in the process of developing an updated workforce facilities master plan. The findings from this project include the need for buildings to have capacity for additional staff and the ability to accommodate shift work, as well as to remain fully functional during shocks or stresses to infrastructure. Investments in resilient workforce facilities are critical to SPU’s climate resilience goals, workforce recruitment/retention, and worker health and safety.

**Part 7. Affordability Impact**

SPU is working to create an asset management program for its workforce facility (WFF) portfolio. The WFF portfolio has been operated utilizing a run-to-failure model. SPU is beginning work to standardize the onboarding, maintenance, management, and capital investment in its workforce facility portfolio. The switch to proactive asset management will help SPU thoughtfully phase investments to minimize impacts to rate payers rather than reacting to expensive failures.

**Part 8. Alternatives and Options to Consider**

The project is currently in the early alternatives development phase which will continue to progress through 2023. Options that are being considered are related to property selection and the program of the new complex, including which functions may remain on the existing NOC and Haller Lake properties.

## 2. In House Water Quality Treatment

<b>SBP Focus Area</b>	Delivering Equitable Essential Services
<b>SBP Goals</b>	Provide reliable, quality services that meet requirements and commitments
<b>SBP Strategy</b>	Provide resources, facilities and remove barriers to ensure frontline service delivery staff can be successful
<b>Type</b>	Investment
<b>SPU Branch/LOB</b>	Water
<b>Executive Sponsor</b>	Alex Chen
<b>Project Manager/Lead</b>	Winsome Robinson Williams
<b>Reporting Cadence</b>	Quarterly
<b>Funding</b>	Water Fund 43000
<b>Last Update</b>	September 2023

### Part 1. Summary of the Investment

SPU’s Tolt and Cedar River Treatment Facilities are vital to providing safe, clean drinking water for customers and meeting regulatory requirements. To ensure continuity of service, SPU will take over operations of both facilities when current Design-Build-Operate (DBO) contracts expire in 2025 (Tolt) and 2029 (Cedar River). Taking over operations, maintenance, and management of these facilities is a major undertaking that will expand our internal capabilities and increase resilience. The Design-Build-Operate (DBO) contract for the Cedar Treatment Facility, which began in 2001, will end no later than 2029. For the purposes of budget planning and as presented in this discussion, it is assumed that in 2029 SPU will take over operation and maintenance of the Cedar Treatment Facility as is already planned for the Tolt Treatment Facility in 2025.

### Part 2. Targeted Commitments and Performance Measures

Major Milestones	Anticipated Outcomes	Timing
SPU takes over operation & maintenance of Tolt facility from American Water	Successful transition with no service impacts	2025
SPU takes over operation & maintenance from Jacobs	Successful transition with no service impacts	2029

### Part 3. Financial Summary

Program Title	Drinking Water Treatment (\$000's)						
Project Name	Tolt Treatment Facility						
	2025	2026	2027	2028	2029	2030	TOTAL
Baseline O&M	5,731	5,960	6,198	6,446	6,704	6,972	38,011
Baseline Capital	2,120	2,247	2,382	2,525	2,676	2,837	14,788
<b>Total Baseline</b>	<b>7,851</b>	<b>8,207</b>	<b>8,580</b>	<b>8,971</b>	<b>9,380</b>	<b>9,809</b>	<b>52,799</b>

Projected O&M	8,113	8,449	8,956	9,494	10,063	10,667	55,743
Proj. Capital	2,120	2,247	2,382	2,525	2,676	2,837	14,788
<b>Total Projected</b>	<b>10,233</b>	<b>10,697</b>	<b>11,338</b>	<b>12,019</b>	<b>12,740</b>	<b>13,504</b>	<b>70,531</b>

Program Title	Drinking Water Treatment (\$000's)						
Project Name	Cedar Treatment Facility						
(\$000's)	2025	2026	2027	2028	2029	2030	TOTAL
Baseline O&M	4,881	5,076	5,280	5,491	5,710	5,939	32,377
Baseline Capital	2,120	2,247	2,382	2,525	2,676	2,837	14,788
<b>Total Baseline</b>	<b>7,001</b>	<b>7,324</b>	<b>7,662</b>	<b>8,016</b>	<b>8,387</b>	<b>8,776</b>	<b>47,165</b>
Projected O&M	5,787	6,192	6,951	7,438	9,911	10,505	46,783
Proj. Capital	2,120	2,247	2,382	2,525	2,676	2,837	14,788
<b>Total Projected</b>	<b>7,907</b>	<b>8,439</b>	<b>9,333</b>	<b>9,963</b>	<b>12,587</b>	<b>13,342</b>	<b>61,570</b>

**Part 4. Capacity Plan to Deliver (Existing/Capital Only)**

This transition will include hiring several new staff for the operation, maintenance, and management of the treatment facility, and this is shown in Part 6.

In addition, support will be needed from different groups:

CIP:

- SPU Security
- PDEB

O&M:

- Human Resources
- Seattle IT and Telephone Services
- SPU Security
- Maintenance Planning
- SPU Safety
- SPU Accounting
- SPU Facilities and Fleets
- SPU Grounds Maintenance

**Part 5. Racial Equity Impact**

In terms of service to our customers, the Tolt Treatment Facility is common to the SPU and its wholesale customers that receive water via the water transmission system. This transition will end the operation of this SPU facility by a private company. It presents the opportunity for SPU to implement RSJ policies at the facility. The hiring process will follow SPU Human Resources policies and procedures and the RSJ considerations and practices incorporated therein.

No final decision has been made about operation and maintenance of the Cedar Treatment Facility after the DBO contract expires; therefore, no projection as to racial equity or vulnerable and historically disadvantaged communities is made herein.

**Part 6. Department Workforce Impacts**

This will require hiring of several positions for operation, maintenance, and management of the facility. The positions included in this budget projection are:

<b>Position</b>	<b>FTEs (Tolt)</b>	<b>FTEs (Cedar)</b>
Water Treatment Manager	1	1
Water Treatment Supervisor	1	1
Water Treatment Operator	9	9
Water Treatment Plant Instrumentation Tech	1	1
Water Treatment Plant Maintenance Tech	2	2
Electrician	2	2
Admin Support Asst	1	1
Utility System Maintenance Tech	1	1
Water Treatment Equipment Tech	1	1
SCADA tech	1	1
SCADA programmer	1	1
WQ Engineer	1	1

**Part 7. Alternatives and Options to Consider**

For the Tolt Treatment Facility, alternatives were presented to the Asset Management Committee in 2022. The AMC approved SPU taking over the operation and maintenance of the Tolt Treatment Facility at that time.

For the Cedar Treatment Facility, alternatives have not yet been evaluated for this situation in 2029. Discussion here is for budget planning only.



### 3. Field Engineering Improvements Program

<b>SBP Focus Area</b>	Strengthening our Utilities Business Practices
<b>SBP Goals</b>	Provide reliable, quality services that meet requirements and commitments
<b>SBP Strategy</b>	Provide resources, facilities and remove barriers to ensure frontline service delivery staff can be successful
<b>Type</b>	Initiative
<b>SPU Branch/LOB</b>	DWW and Water LOB/Shared Services
<b>Executive Sponsor</b>	Ellen Stewart and Alex Chen
<b>Project Manager/Lead</b>	Tara Wong Esteban
<b>Reporting Cadence</b>	Annually
<b>Funding</b>	New O&M Add , 0.67 DWW, 0.33 Water
<b>Last Update</b>	September, 2023

#### **Part 1. Summary of the Investment**

To improve the delivery of operable Drainage and Wastewater projects, SPU will hire senior engineers to provide O&M expertise and support to project teams. These engineers will be embedded with frontline crews to better understand and represent their work, provide quick turnaround on design solutions and real-time help to resolve problems in the field, support crews as they respond to emergency or special projects, and represent O&M needs on capital projects.

As part of the Affordability and Accountability (A&A) Initiative, Strategy 2 – Improve Capital Delivery; Item H - Incorporate Operational Considerations, SPU looked at how to improve delivery of operable DWW projects. Data gathering and problem definition began in 2020 and covered all operable facilities. In 2021, the focus was narrowed to collect information only around DWW Pump Station program because it contains the bulk of current and proposed operable facility projects.

We interviewed many groups from SPU to document challenges, lessons learned, and successes. These interviews included staff from operations, maintenance, design engineering, project managers, line of business representatives, asset managers, and construction management. We consistently heard that we needed dedicated staff whose primary role is to provide operations and maintenance (O&M) expertise and support on project teams. We heard that the O&M voice was missing on all capital projects (not just projects with operable components) and that O&M engineering support is needed in the field to support our crews.

Additionally, we heard directly from frontline staff across SPU who participated in the Empowering Frontline Staff initiative (thru Shaping the Future) that they wanted field engineering O&M positions to support key field operations units. The consensus was that the O&M engineer should be embedded with the frontline crews to build trusting relationships and to both understand and represent their work and their needs. The engineer could provide quick turnaround on design solutions, help crews problem solve issues in the field more quickly,

support crews as they respond to emergency projects or special projects, and represent O&M needs on capital projects.

This investment provides 3.0 FTE Senior Engineer positions:

- 1.0 FTE dedicated to Wastewater
- 1.0 FTE dedicated to Drainage
- 1.0 FTE dedicated to Electrical

Senior level positions are needed to provide experienced engineers who can make decisions and judgement calls independently when they are in the field. These three new positions could report to Shared Services but should be co-located with our frontline staff. This investment will supplement the work of the single mechanical engineer that currently supports our Water and DWW crews who is planning to retire in early 2025. Recently, a Senior Civil Engineer was hired to shadow the sole Mechanical Engineer and will be trained over the next 20 months to become his replacement. In turn, this newly hired Civil Engineer will be able to on-board and train the new O&M Engineers. The new O&M Engineers will 1) provide engineering support and direction in the field to frontline staff and 2) represent O&M needs on capital projects.

This initiative also includes two electric vehicles for these engineers to share so they can spend time in the field with crews and be readily able to respond to emergencies or calls for assistance.

## **Part 2. Targeted Commitments and Performance Measures**

Major Milestones	Timing
Hire 3.0 new Sr Engineers	Q2 2025

## **Part 3. Financial Summary**

Program Title	Field Engineering Improvement Program (\$000's)						
Project Name	O&M Engineer						
	2025	2026	2027	2028	2029	2030	TOTAL
Baseline O&M	574	574	574	574	574	574	3,444
Baseline Capital	n/a	n/a	n/a	n/a	n/a	n/a	n/a
<b>Total Baseline</b>	<b>574</b>	<b>574</b>	<b>574</b>	<b>574</b>	<b>574</b>	<b>574</b>	<b>3,444</b>

Annual costs for 3 Sr Engineers at \$182,573 each, plus costs for leasing and maintenance of electric vehicles

## **Part 4. Capacity Plan to Deliver (Existing/Capital Only)**

N/A – this is an O&M cost

### **Part 5. Racial Equity Impact**

This investment ensures we are adequately supporting and representing the needs of our O&M staff. We invest millions of dollars in capital projects and need to improve identifying O&M issues before the projects are completed. Otherwise, our limited frontline workforce is asked to retrofit or correct new construction which pulls them away from completing routine maintenance or other high priority work.

We have lost institutional knowledge as experienced employees have left and at times our frontline staff are on their own trying to figure out solutions to problems. The O&M engineers will become integrated with frontline staff and will eventually build a relationship of trust and respect (as demonstrated by our single mechanical engineer).

Today's lack of support for O&M impacts a field workforce that has a higher percentage of people-of-color. They inherit issues and problems through capital projects that should not be their responsibility to resolve. These problems are far outside of their classifications, were not planned for or identified ahead of time, and frontline staff do not have any influence over the capital programs and processes.

### **Part 6. Climate and Sustainability Impact**

O&M engineers will support installation of new and replaced assets that provide: improved water quality in creeks and lakes (green stormwater infrastructure (GSI), CSO control), heat island reduction (GSI), flood and landslide mitigation (drainage projects), drinking water resilience (water transmission and watersheds).

### **Part 7. Affordability Impact**

O&M Engineers will support project teams resulting in less resources (money and labor) spent addressing issues with newly constructed or replaced assets. Providing timely support for our crews will lower labor and equipment costs for repairs and will improve the longevity of repaired assets.

### **Part 8. Alternatives and Options to Consider**

For capital projects, SPU experimented with eliminating the O&M Engineer role and instead asked the Line of Business Representative to represent and identify O&M needs and requirements on capital projects. We've seen over the past several years that this model is not efficient or effective. Other project team members from DWW SOPA and Project Delivery and Engineering Branch (PDEB) engineering attempt to liaise with O&M staff to meet this need, but this isn't efficient or effective either. The current system often results in rework/fixes/retrofits on newly constructed capital projects costing additional funding and taking frontline staff away from their core work.

Frontline staff need engineering support when dealing with complicated issues in our facilities and systems. We should duplicate a model that works well – the way our single mechanical engineer interacts with and supports crews, capital projects, and emergency response. PDEB engineering can also provide occasional support and will continue to do so when a design requires a licensed engineer with specific expertise and the ability to seal designs. PDEB engineering does not have the capacity to respond to the frequency and urgency of many smaller issues that arise - this can be better met by embedded O&M Engineering staff.

To meet the unpredictable nature and urgency of emergency projects and to maintain continuous operation of our DWW and Water systems, frontline staff need their own dedicated O&M engineers whom they can call upon when needed. PDEB needs dedicated O&M engineers who are assigned to support capital projects and who are empowered to represent the needs of the end-user. Asset managers need dedicated O&M engineers so they can return their focus on strategic asset management work instead of trying to represent the needs of O&M on capital projects.

#### 4. SPU Support Services for the Unsheltered

<b>SBP Focus Area</b>	Delivering Equitable Essential Services
<b>SBP Goals</b>	Make equitable investments to improve services for underserved and over- burdened communities.
<b>SBP Strategy</b>	Prioritize and support equitable access to essential services.
<b>Type</b>	Investment
<b>SPU Branch/LOB</b>	DWW, PCC
<b>Executive Sponsors</b>	Gary Christiansen, Lee Momon
<b>Project Manager/Lead</b>	Chris Wilkerson
<b>Reporting Cadence</b>	Quarterly
<b>Funding</b>	Baseline funding
<b>Last Update</b>	November, 2023

##### Part 1. Summary of the Investment

###### *RV Remediation Program*

The RV Remediation Program addresses the public health and safety impacts of trash and debris produced by recreational vehicles (RVs) and other vehicles occupying the public Right-of-Way. In 2022, these efforts were implemented by Seattle Public Utilities (SPU) and performed in collaboration with the Unified Care Team (UCT), an intradepartmental team formed under Mayor Harrell's administration. UCT is composed of Seattle Parks and Recreation (SPR), Seattle Department of Transportation (SDOT), Seattle Human Services Department (HSD), Seattle Police and Fire departments, and Seattle Finance and Administrative Services (FAS).

Some of the main objectives are to improve public access to the right-of-way, minimize public health and safety hazards associated with RV camping, and increase opportunities for those experiencing homelessness to find stability.

In addition to the RV Remediation Program, In 2022, SPU started a Pilot called Geo-Cleans to address growing community concerns associated with public health and safety risks involving clusters of RVs; SPU conducts Geo Cleans to provide a swift and consistent response to mitigate ongoing trash and debris from RVs located throughout City neighborhoods. The Geo Clean sites identified for routes are addressed weekly. The main objectives include improved access to the right-of-way and minimizing public health and safety hazards associated with RV camping without requiring the RV occupants to move their vehicles.

Another program addressing community and sanitation issues presented by RVs in the public Right-of-Way is the RV Wastewater Pump Out program operated by the DWW LOB, which prevents dumping of wastewater storage tanks onto the ground or into drainage basins.

###### *RV Wastewater Pump Out Program*

Nearly half of Seattle’s unhoused population live in vehicles, many in recreational vehicles (RV’s). These recreational vehicles are often concentrated in encampments with minimal access to sanitary sewer or pump out removal (the nearest pump out station is 25 miles outside of Seattle city limits). Many of these RV’s have broken plumbing or are unable to be moved, compounding the challenge of removing wastewater with traditional methods. RV’s occupying encampments often dump waste in drainage basins, streets, or adjacent properties. Spills attributed to RV wastewater spills showed an exponential increase until peaking in 2019, the year the RV Wastewater program was first piloted. Since the RV Wastewater Program’s inception, we have realized a 72% drop in these incidents (see graph below).

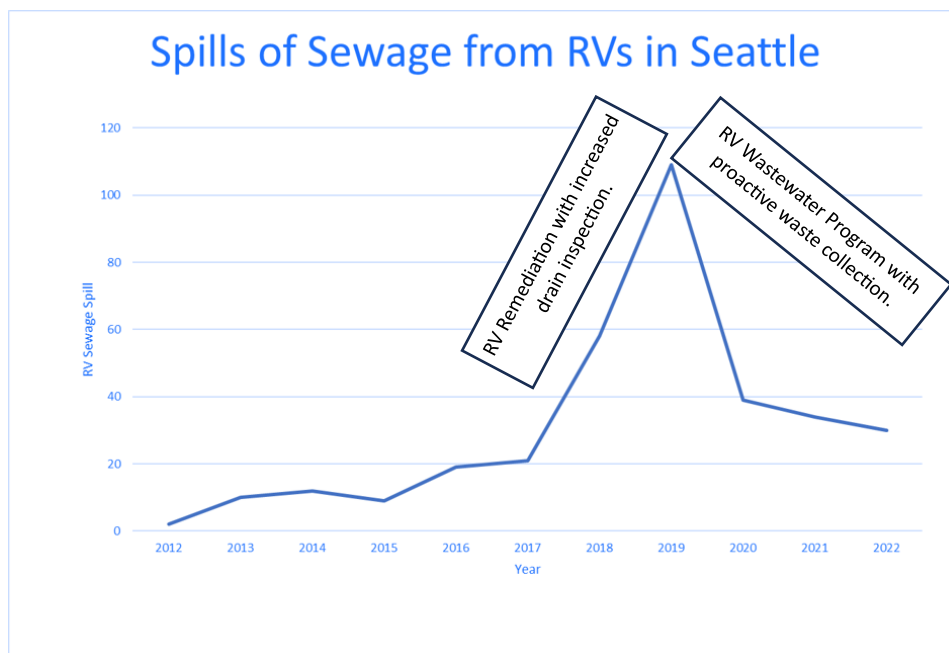

As a result of the drop in incidents of illegal dumping because of the proactive pumping of wastewater, SPU’s Spill Response Team members have been able to shift their focus to other areas of Environmental Compliance like line cleaning, business inspections and spill prevention.

### *Encampment Trash Program*

The Encampment Trash Removal Program, also referred to as the Purple Bag Program, provides proactive weekly garbage service to nearly 30 selected homeless encampments. The goal is to improve encampment conditions and minimize public health and safety hazards by reducing community trash.

SPU works closely with city agencies such as SDOT and Parks, community stakeholders, and advocates to address encampment trash. SPU provides purple garbage bags issued to encampment residents by contracted outreach partners.

The program activities include collecting and disposing of authorized garbage, bulky items, and hazardous materials and distributing authorized purple garbage bags to encampment residents. On-call trash collection is available at least 20 feet away from encampments to avoid collecting personal property. Site assessments, data collection, and outcome

SPU serviced an average of 30 unsanctioned homeless encampments and collected over 782,000 pounds of trash and debris. The utility also engaged with over 2,900 encampment residents, distributing over 11,000 Purple Bags.

**Part 2. Targeted Commitments and Performance Measures**

Major Milestones	Anticipated Outcomes	Timing
Average 100 RV Pump-outs /Month	<40 Spill Responses/Year (72% reduction)	Annually
5,246 wastewater collections	~250,000 gallons of wastewater diverted from the environment	Annually
100+ Geo Cleans per year	>500,000 pounds of trash collected	Annually
30+ Encampment sites serviced per year	>750,000 pounds of trash collected	Annually

**Part 3. Financial Summary**

Program Title	SPU Clean City and Support Services for the Unsheltered (\$000's)						
Project Name	RV Remediation and Encampment Trash Programs						
	2025	2026	2027	2028	2029	2030	TOTAL
Baseline O&M	3,100	3,100	3,100	3,100	3,100	3,100	18,600
Baseline Capital	n/a	n/a	n/a	n/a	n/a	n/a	n/a
<b>Total Baseline</b>	<b>3,100</b>	<b>3,100</b>	<b>3,100</b>	<b>3,100</b>	<b>3,100</b>	<b>3,100</b>	<b>18,600</b>

As Clean City Division programs are funded by the **City General Fund** and dependent on budget decisions outside of SPU, we cannot predict our budget beyond the current year. Numbers provided assume current level of effort is funded.

Program Title	SPU Clean City and Support Services for the Unsheltered (\$000's)						
Project Name	RV Wastewater Pump Out Program						
	2025	2026	2027	2028	2029	2030	TOTAL
Baseline O&M	550	550	550	550	550	550	3,300
Baseline Capital	n/a	n/a	n/a	n/a	n/a	n/a	n/a
<b>Total Baseline</b>	<b>550</b>	<b>550</b>	<b>550</b>	<b>550</b>	<b>550</b>	<b>550</b>	<b>3,300</b>

As a part of SPU’s proposed 2021-2022 budget, the RV Mobile Pump Out pilot was budgeted [DWW base budget] through 2022. In 2023 the program was fully evaluated and adopted as a

permanent program. This included FTE position allocation and funding for the required services. Funding for the program comes from rate revenue. This financial summary is based on the projected budget in 2023 dollars.

#### **Part 4. Capacity Plan to Deliver**

The RV Remediation and Encampment Trash Programs are staffed by 2.5 FTE pockets and supported by the General fund.

The RV Wastewater Pump Out program is staffed by 1.5 FTE pockets and supported by contract wastewater service provider and partnership MOAs with several non-profit community-based organizations, including St. Vincent De Paul.

#### **Part 5. Racial Equity Impact**

The Clean City programs are committed to establishing inclusive and equitable relationships with all communities and individuals inside and outside the utility. The Division will continue intentionally fostering SPU's workplace culture, public outreach, engagement work, and service equity initiatives throughout the City of Seattle.

The RV Wastewater Pump Out program focuses on pumping live-in RV wastewater tanks wherever they are parked throughout the City of Seattle. Individuals served by this program are very low income. However, because the community served has a general lack of trust and unwillingness to provide personal information, collection of income, race, or household data in order to avoid potential conflict and refusal to accept services.

#### **Part 6. Climate and Sustainability Impact**

In 2023, Seattle Public Utilities Clean City Division collected and disposed of 1.5 million pounds of garbage from GeoCleans, RV remediations, and encampments, contributing to environmental protection and public health preservation.

Since the RV Wastewater Pump Out program's inception in 2019 there have been approximately 250,000 gallons of wastewater diverted from the environment protecting public health and critical fish habitats.

#### **Part 7. Affordability Impact**

The Clean City programs are General Funds, and no Rate Payer dollars are used to fund the programs.

Depending on the complexity of the clean-up, proactive RV Wastewater pumping is 25-75% less costly than a reactive response to illegally dumped wastewater.



## **Part 8. Alternatives and Options to Consider**

Starting in 2023, The Clean City Division initiated an RV Rescue Pilot program to help RVs and other motor vehicles avoid being towed due to not being able to move their vehicle every 72 hours. The program offers small amounts of gasoline, tire inflation, jump starts, and other minor maintenance repairs to enable the vehicle to move off the block face and comply with the City of Seattle's 72-hour On Street Parking Ordinance.

The results of 2023 will determine if this Pilot should become a full Clean City Division program.

A permanent RV Dump Station has been considered, however has not been moved forward due to staffing limitations.

## 5. Duwamish Valley Resilience

<b>SBP Focus Area</b>	Delivering Equitable Essential Services
<b>SBP Goals</b>	Make equitable investments to improve services for underserved and over- burdened communities.
<b>SBP Strategy</b>	Prioritize and support equitable access to essential services
<b>Type</b>	Investment
<b>SPU Branch/LOB</b>	Drainage & Wastewater
<b>Executive Sponsor</b>	Ellen Stewart
<b>Project Manager/Lead</b>	TBD
<b>Reporting Cadence</b>	Quarterly (for investments)
<b>Funding</b>	Continued Base Funding + Increased Funding
<b>Last Update</b>	NA

### Part 1. Summary of the Investment

This investment is a holistic approach to fostering flood mitigation, water quality, salmon habitat improvement, and community resilience in Georgetown and South Park. The investment is focused on integrating, coordinating, and aligning three workstream funding sources described below to deliver better outcomes to community.

#### *Existing SPU DWW CIP Funded*

SPU has approximately \$93M for DWW infrastructure, plus an additional \$83M for Duwamish River sediment remediation work, allocated in the 2025-2030 budget. These investments include multiple near-term DWW infrastructure investments.

The South Park Roadway and Drainage Project, Phase 2 will install pipes to expand the footprint and the number of blocks served by the recently completed South Park pump station. The South Park Stormwater Quality Facility will remove pollutants from stormwater being pumped by the South Park Pump Station before it enters the Duwamish River. Additional flood reduction and water quality improvement investments are anticipated in collaboration with King County Wastewater Treatment Division’s (WTD) Long-term Planning for sewer overflow reduction.

The Lower portion of the Duwamish Waterway is a CERCLA Superfund cleanup site located within the lowest five miles of the Duwamish River. The cleanup of the contaminated river sediments is managed by the US Environmental Protection Agency (EPA) with the Washington Department of Ecology (Ecology) overseeing the uplands source control work to prevent recontamination of the sediments once cleanup has begun. SPU and SCL partner with King County and Boeing to accomplish the cleanup work, including providing stakeholder input into procedures and approaches and financially contributing per allocation agreement. The Upper Reach portion of the site (River Mile 3.0-5.0) is scheduled for cleanup construction starting in Fall 2024. The next portion of the river slated for cleanup is the Middle Reach (River Mile 1.0-

3.0) with a determination of sufficiency scheduled for issuance in 2027. The [Lower Duwamish Working Group](#) website provides more information on the cleanup.

#### *SPU funded via increased budget authority – South Myrtle Street Drainage & Water Quality*

Prior to the cleanup of the river sediments, the EPA relies on Ecology to recommend a determination of “Sufficiency”, stating that inputs of pollutants to the river are sufficiently controlled and cleanup may progress with low risks of recontamination. For Ecology to issue a sufficiency determination for the Middle Reach of the Lower Duwamish Waterway, the City will need to improve the right of way, add drainage conveyance as necessary, and design and construct one or more small treatment systems in the vicinity of the outfalls at S Myrtle St and S Garden St in the industrial area of Georgetown. Unless runoff from this small drainage area is treated, Ecology will inform the EPA that the Middle Reach is not sufficiently controlled, and the cleanup of the Lower Duwamish Waterway will be delayed. This delay will continue until this drainage system is found to be sufficiently controlled. For this reason, SPU is proposing to add the South Myrtle St Drainage Project, which is needed to secure sufficiency determination.

This O&M budget increase is needed for staffing the added water quality facilities (South Myrtle St Drainage and South Park Water Quality Facility).

#### *Duwamish Valley Resilience Investments*

On 12/27/2022, the Duwamish River overtopped its banks, impacting acres of industrial and residential land, 49 properties, and overwhelming existing sewer systems. This was the second of two impactful tidal river flooding events in 2022. Flooding will increase in severity and frequency with expected sea level rise (SLR). Duwamish Valley land comprises 80% of all Seattle lands prone to SLR-related flooding. Planned drainage and sewer system investments will help alleviate stormwater flooding and sewer backups in the area, but they will not address tidal flooding or SLR adaptation infrastructure. Unchecked, this will result in recurrent damage and expense to residents, businesses of regional importance, and the City, costing millions per year. It will also unduly burden Black, Indigenous, people of color (BIPOC); immigrants; and families with low wealth who comprise most of the adjacent neighborhoods. Duwamish Valley Resilience Investments pertain to long-term adaptation to SLR-related flood risk and community resilience. These investments are adjacent and complementary to the DWW CIP described above but are separate because they relate to flooding from river and estuarine processes in the highly channelized and developed river system.

Given SPU’s expertise with water management, complex capital infrastructure and funding delivery, and regulatory compliance, as well as the tidal impact on SPU drainage and conveyance infrastructure systems in the area, SPU will act as a primary coordinator and facilitator for the Duwamish Valley Resilience Investments planning and project delivery in collaboration with other City departments. SPU’s DWW funding will be focused on protecting our DWW infrastructure from flooding, to prevent sewer backups, and to address water quality source control and sediment remediation. The work of the proposed Duwamish Valley

Resilience Investments will leverage the significant DWW infrastructure investments and will support development of additional funding partnerships where external funding is required. This includes, for instance, the pursuit of King County Flood Control District, Washington Climate Commitment Act, Department of Ecology, and Floodplains by Design funding, salmon habitat funding, and support for SLR-related flood control planning and flood preparedness work that will be simultaneously beneficial to SPU DWW service delivery.

The City has a long history of involvement in the Duwamish Valley and Superfund site. In addition to the City’s role in the Lower Duwamish Waterway Group (LDWG), we have committed to extensive investments in the area. 2016, the City launched an interdepartmental Duwamish Valley Program (DVP) to advance environmental justice and equitable development. The Duwamish Valley Action Plan, released in June 2018, is a shared City-community vision to promote collaboration, guide City investments, and build resilience for years to come. It commits the City to develop five long-term environmental justice strategies for: Anti-Displacement, Workforce Development, Climate Adaptation, Parks and Open Space, and Health. The Duwamish Valley Resilience team at SPU will collaborate closely with and help coordinate the Duwamish Valley Interdepartmental Team (IDT) together with the Office of Sustainability and Environment (OSE) and the Office of Planning and Community Development (OPCD). SPU also contributes to the salmon recovery work in the Green-Duwamish watershed and leads and coordinates city investments in salmon recovery in the Duwamish River basin. SPU funds a portion of the Duwamish Basin Steward who helps advance salmon recovery projects.

Since 2019, the related body of work has been funded almost completely by philanthropic support from the Lincoln Land Institute’s Center for Community Investment (CCI), Robert Wood Johnson Foundation (RWJF), and the Seattle Foundation. Recent flooding events have amplified and accelerated the need for this nascent work. The next phase of work is being funded by the King County Flood Control District and a FEMA Building Resilient Infrastructure and Communities (BRIC) grant is pending. This early vision and concept development work in partnership with community will map out a path for future sea-level rise adaptation infrastructure, financing and funding for the infrastructure, and community capacity building.

**Part 2. Targeted Commitments and Performance Measures**

Major Milestones	Anticipated Outcomes	Timing
DWW CIP Base <ul style="list-style-type: none"> <li>• Initiate construction of drainage/conveyance Ph 2 (</li> <li>• Initiate construction of the South Park Water Quality Facility (2030)</li> <li>• Develop approach for flood reduction and WQ improvement in Georgetown in alignment with King County led CSO efforts</li> </ul>	<ul style="list-style-type: none"> <li>• Flood mitigation</li> <li>• Water quality improvement</li> </ul>	
DWW CIP Sediments		

<ul style="list-style-type: none"> <li>Initiate in-water Superfund cleanup of Duwamish River, beginning with the Upper Reach (Fall 2024)</li> </ul>	Superfund sediment cleanup	2024-2032
<p>DWW CIP – With supplemental budget request</p> <ul style="list-style-type: none"> <li>S. Myrtle Street Drainage &amp; Water Quality Project</li> </ul>	Construction NTP	2028
<p>Duwamish Valley Resilience</p> <p><i>Note: milestones and outcomes rely on the securing external funding for 3 key positions to matrix from other departments</i></p> <ul style="list-style-type: none"> <li>Define and launch new interdepartmental structure</li> <li>Develop shared vision with community for infrastructure and social resilience approaches</li> <li>Preliminary design of SLR infrastructure</li> <li>Pursue community wealth building strategies including workforce development, local procurement strategies</li> <li>Draft a Duwamish Valley Master Plan, including land use/zoning, affordable housing, open space, shoreline master program and associated permitting.</li> <li>Develop Funding and Partnership Strategy for Capital and Social Infrastructure</li> <li>Support city-wide efforts to improve Chinook habitat through restoration projects including obtaining grant funding</li> </ul>	<ul style="list-style-type: none"> <li>Cohesive community engagement</li> <li>Emergency flood preparedness and response</li> <li>Long-term sea-level rise resilience plan</li> <li>Secured external funding</li> </ul>	2030

**Part 3. Financial Summary** Note the “Totals” are just for the 6yr period shown

Baseline Budget

Program Title	Duwamish Valley Resilience Investments (\$000's)						
Project Name	Various						
	2025	2026	2027	2028	2029	2030	TOTAL
Baseline O&M (non-labor – DV Resilience)	500	500	500	500	0	0	2,000
Baseline Capital – DWW Capacity & Water Quality	8,000	12,500	27,500	19,400	15,200	10,200	92,900
Baseline Capital – DV Superfund sediments work	14,800	9,800	9,800	16,700	17,400	14,400	83,000
<b>Total Baseline</b>	<b>23,300</b>	<b>22,800</b>	<b>37,800</b>	<b>36,600</b>	<b>32,600</b>	<b>24,600</b>	<b>177,800</b>

Supplemental budget Request

	2025	2026	2027	2028	2029	2030	TOTAL
O&M -new FTE WQ facility O&M	100	100	100	100	300	300	1,000

Capital - South Myrtle Street Drainage & Water Quality	500	500	500	7,000	5,000	4,500	18,000
<b>Total Supplemental Budget</b>	600	600	5,100	7,100	5,300	300	<b>19,000</b>

**Part 4. Capacity Plan to Deliver (Existing/Capital Only)**

No proposed staffing adds are requested of SPU for the delivery of this work. However, the water quality infrastructure planned for delivery through this investment is beyond SPU's ability to maintain without additional staffing.

**Part 5. Racial Equity Impact**

The Duwamish Valley is ancestral home of the Duwamish Tribe and 5,600 people, of whom 42% are immigrants, 37% are Latinx, and 63% are people of color. Additionally, the lower reaches of the Duwamish River are prime sites for fishing relevant to Muckleshoot and Suquamish treaty rights, including the Endangered Species Listed, Chinook salmon. Most residents (72%) live in poverty. Residents disproportionately face social and environmental stressors; life expectancy is 13 years lower than Seattle's white, upper-income neighborhoods, and the Duwamish River Superfund site runs through the Duwamish Valley and its communities.

The work within this investment will advance environmental justice and equitable development in the area, reducing the recurrent damage and expense to this historically disinvested community.

Specifically with respect to the proposed addition of the South Myrtle Street Drainage & Water Quality Project, these investments will help keep the river clean-up project on schedule. Many of these residents rely on the river for recreation, economic opportunities, and as a source of food. Delays of the cleanup of the river would be unacceptable for the residents of Seattle, and more specifically, the residents of these adjacent neighborhoods.

**Part 6. Alternatives and Options to Consider**

SPU has previously explored options beyond building additional infrastructure with funding for the South Myrtle Street Drainage & Water Quality Project. SPU has been actively implementing a source control program within the Lower Duwamish Waterway since the early 2000s and has undertaken all feasible Best Management Practices within the S. Myrtle St and S. Garden storm drain areas to reduce contaminant loading to the river. However, samples indicate that contaminant loading remains elevated in the stormwater solids samples immediately adjacent to the outfalls and a physical intervention is recommended. Options analysis will identify roadway improvements and conveyance options to route stormwater to one or more small treatment systems in the study area.

Regarding the Duwamish Resilience Investments, the City has the alternative to do nothing, since responsibility for river flooding does not technically fall within SPU's domain. However, this path of action would result in complex and layered problems, including flood/system overwhelm risk for DWW infrastructure, increased risk of recontamination of the Duwamish River associated with flood events, and undue and inequitable burdening of residents and businesses in an EJ community with a history of public underinvestment.

## 6. Shape Our Water – Citywide and Focus Area Planning

<b>SBP Focus Area</b>	Stewarding Environment and Health
<b>SBP Goals</b>	Develop One Water Resilience from our watersheds to city to Sound.
<b>SBP Strategy</b>	Invest in strategic plans, projects, and programs that advance a holistic One Water approach.
<b>Template Type</b>	Initiative
<b>SPU Branch/LOB</b>	Drainage and Wastewater
<b>Executive Sponsor</b>	Ellen Stewart
<b>Project Manager/Lead</b>	Leslie Webster
<b>Reporting Cadence</b>	Annual
<b>Funding</b>	Current funding plus addition of 3 FTE .
<b>Last Update</b>	September 2023

### **Part 1. Summary of the Initiative**

Over the past few years, SPU has been developing the Shape Our Water Plan – an integrated citywide plan for the next 50 years of drainage and wastewater investments in Seattle. Shape Our Water will include both long-term strategies and a near-term action plan that will guide SPU’s future investments in policies, programs, and projects that improve the performance and resilience of our drainage and wastewater systems while optimizing social and environmental benefits, salmon habitat, for the City. Under this initiative, SPU will continue to track progress on completing the citywide Shape Our Water plan and the beginning of implementation. Funding for this has been - and will continue to be - included in the baseline budget.

Simultaneous to Shape Our Water development, SPU has been piloting and refining our approach to focus area planning. This initiative expands on the existing Shape Our Water initiative to address an immediate gap in resources to perform focus area planning in parallel with the Shape Our Water Plan to increase predictability in development and increase operational efficiency over time. This initiative will scale-up technical planning and community engagement in high priority focus areas, such as:

- Neighborhood drainage and sewer plans in OPCD’s priority neighborhoods for community planning.
- System layout plans for areas that lack adequate sewer or drainage systems and that are expected to experience increased development over the next decade.
- Integrated stormwater and sewer plans in neighborhoods with a history of underinvestment and complex, present-day capacity and asset management challenges such as Georgetown and Rainier beach.
- Creek watershed planning to reduce tire dust pollutants (6PPD-Q).
- Creek culvert replacement strategy to sequence asset management investments and fish passage barriers removal in Seattle’s urban creeks, including engagement with local Tribes and permitting agencies.



- Stormwater and sewer system improvement plans for SDOT’s priority corridors for right-of-way investments.

Currently, three (3) full-time term-limited employees (TLEs) are supporting both citywide and focus area planning needs in the Drainage and Wastewater. This initiative will replace these temporary positions, providing stable and sustainable staff resources for this critical focus area planning work in the years ahead. This initiative will be resourced by three new staff with support from existing, repurposed Services budget. The costs to fund this initiative are shown in the table below:

Initiative Title	Shape Our Water – Focus Area Planning (\$000’s)	
	Per Year (2025-2030)	TOTAL
O&M Labor	538	3,227
<b>Total Baseline</b>	<b>538</b>	<b>3,227</b>

### **Part 2. 2025-2027 Commitments**

Major Milestones	Qtly Timing
Document focus area planning approach and refine focus area planning tools	Q2, 2025
Complete first round of focus area plans (3-6 area plans) and transition to implementation	TBD, 2026-2027*
Initiate and complete second round for focus area plans	TBD, 2028-2030*

*\*Timing of plan completion will depend on scale and complexity of defined plan area. Plan schedules will be determined in Q4, 2025 when the charters for the selected plans are developed.*

### **Part 3. Racial Equity Impact**

A [racial equity framework](#) was developed for the Shape Our Water Plan and is being used to inform focus area planning. Focus area plans will help SPU meet the goals of the Shape Our Water [community vision](#). Community engagement associated with the development of focus area plans will center BIPOC voices and resource community members for their expertise and participation. Racial equity was incorporated into the citywide prioritization of sewer and stormwater challenges. Supporting this initiative will accelerate integrated, multi-benefit solutions to address high-priority stormwater and sewer challenges in neighborhoods with a greater share of disadvantaged communities.

### **Part 4. Climate and Sustainability Impact**

Both Shape Our Water and focus area planning aim to increase the resilience and sustainability of Seattle’s drainage and wastewater systems. Two of the goals of Shape Our Water are to 1) *invest in drainage and wastewater infrastructure that can adapt to future environmental*

*challenges and build system resiliency - especially in areas most vulnerable to environmental hazards, and 2) Treat all water as an essential resource and ensure it is managed in a sustainable and integrated way.*

### **Part 5. Affordability Impact**

Affordability is a major driver of Shape Our Water and focus area planning. These integrated planning efforts identify investments that solve multiple drainage and wastewater challenges and align those investments with mobility, open space, and livability improvements. This means more value for SPU customers in the future. Furthermore, one of the stated goals of the Shape Our Water is for SPU to *provide accessible and affordable drainage and wastewater services to community members regardless of economic or housing status.*

### **Part 6. Alternatives and Options to Consider**

If this initiative were not adopted, focus area planning resources would remain at their present level. Currently, the planning section has three (3) permanent positions focused on citywide planning and two (2) permanent positions focused on planning in priority geographic areas; one planning in uncontrolled CSO basins in compliance with NPDES permit requirements and the consent decree, and the other planning in urban villages. There are no resources for other area-based priorities for planning.

The lack of focus area planning would result in a less holistic approach to CIP projects. The CIP projects that move forward would take much longer to complete as they struggle to compensate for the lack of initial planning, and potentially cost more as well because partnering relationships are harder to develop in options analysis or design.

This initiative is scalable – in other words, more FTEs and associated professional services support could be added to accelerate the pace of stormwater and sewer plan development. Alternatively, fewer FTEs or professional services support could be added, resulting in a deceleration of plan development.

## 7. Water Supply Planning for the Next 50 Years

<b>SBP Focus Area</b>	Stewarding Environment and Health
<b>SBP Goals</b>	Develop one water resilience from our watersheds to city to Sound.
<b>SBP Strategy</b>	Invest in strategic plans, projects, and programs that advance a holistic One Water approach.
<b>Template Type</b>	Initiative
<b>SPU Branch/LOB</b>	Water
<b>Executive Sponsor</b>	Alex Chen
<b>Project Manager/Lead</b>	Julie Crittenden
<b>Reporting Cadence</b>	Annual
<b>Funding</b>	Baseline
<b>Last Update</b>	October 2023

### **Part 1. Summary of the Initiative**

SPU assesses and plans for our customers and water supply needs frequently. We are in a period of particularly focused, long-term evaluation for 2023-2029 due to several projects. These projects include:

- Climate Change Hydrology Analysis
- South Fork Tolt Federal Energy Regulatory Commission (FERC) Re-licensing
- Cedar Falls Long-Range Plan
- Supply Alternatives Analysis

These projects are based on a framework of understanding 1) How much water we need; 2) How much water we have, especially in light of expected climate change impacts; and 3) How we will adjust. The results will provide important information for looking out 40-50 years and updating our Water System Plan, with the next plan due in 2029.

### **Part 2. 2025-2027 Commitments**

<b>Major Milestones</b>	<b>Qtly Timing</b>
Updated climate change hydrology analysis	4Q 2024
Cedar Falls Long Range Plan recommendations	1Q 2026
Supply Alternatives Analysis	1Q 2026
South Fork Tolt Re-Licensing: Study Plan completed	1Q 2025
South Fork Tolt Re-Licensing: Final Study Report completed	4Q 2026
South Fork Tolt Re-Licensing: License application filed	2Q 2027

### **Part 3. Racial Equity Impact**

- Proper planning will ensure our region and all customers have sufficient water supply.

- The planning work identified in this initiative includes tribal engagement, as our watersheds and water supply actions are in historical lands of several Salish Sea tribes.

#### **Part 4. Climate and Sustainability Impact**

Climate change, and expected changes in weather types and timing, are a major factor driving these long-term water supply and system plans. The intent of developing these plans is to adjust for climate change and to be prepared to continue providing water for people and fish (e.g., aquatic habitats) for decades into the future.

#### **Part 5. Affordability Impact**

Proper planning, especially focused on our existing supply and adequate water conservation actions, will help ensure our current water supplies will be adequate for decades and avoid the need to develop new supply. This keeps our rates more affordable.

## 8. Cedar and Tolt Watershed Resilience

<b>SBP Focus Area</b>	Stewarding Environment and Health
<b>SBP Goals</b>	Develop one water resilience from our watersheds to city to Sound.
<b>SBP Strategy</b>	Advance nature-based and community-centered climate adaptations and solutions.
<b>Template Type</b>	Initiative
<b>SPU Branch/LOB</b>	Water
<b>Executive Sponsor</b>	Alex Chen
<b>Project Manager/Lead</b>	Amy LaBarge
<b>Reporting Cadence</b>	Annual
<b>Funding</b>	O&M, CIP, grants
<b>Last Update</b>	9/29/2023

### Part 1. Summary of the Initiative

This initiative protects the source supply watersheds of Seattle’s drinking water system, which consist of 100,000 acres of forests that serve as the first filter for high quality drinking water provision and an array of other ecosystem goods and services. Climate change and associated threats of reduced snowpack, drought, extreme precipitation events, and wildfire have the potential to impact watershed ecosystem integrity, water supply, and drinking water quality.

Included in this initiative are ongoing programs and projects that are in place to continually develop resilience in source supply watersheds – the Cedar River and South Fork Tolt River Municipal Watersheds. These programs address watershed protection, wildfire risk management, forest ecosystem management, monitoring, and continuous improvement in all these areas. The **bolded elements** below indicate areas for continued investment.

#### Watershed Protection:

- Maintain watershed closure and security;
- Manage access and activities during high fire danger days to prevent human-caused wildfire ignitions;
- Maintain and improve watershed road networks to protect water quality and access in the face of extreme events;
- Maintain monitoring, inspection, and response programs to detect, prevent, and address multiple threats including sanitation, hazardous materials, and invasive species.

#### Wildfire Risk Management:

- Maintain preparedness to respond and suppress wildfires with qualified initial attack teams and **equipment**;

- Maintain partnerships and qualifications for suppression response – WA DNR, USFS, EOC;
- Prepare for **rapid post-fire response** and recovery to reduce erosion before first precipitation events and protect water quality, protect critical assets, monitor post-fire impacts, conduct ecosystem recovery to restore water quality and habitats;
- **Create defensible space** around critical assets and core roads to provide safe access and anchor points to aid fire suppression;
- Continue to assess changing risk and potential impacts to drinking water supply and mitigation efforts to ameliorate risk;
- Consider forest fuel treatments in the watershed landscape to reduce wildfire rate of spread and fire intensity to mitigate risk.

Forest Management:

- **Implement the Cedar River Watershed Forest Management Plan (2023)** to meet multiple objectives of water cycle regulation, old forest protection and development, climate resilience, tribal wildlife habitat objectives, and wildfire risk reduction;
- Implement the forest restoration programs in the South Fork Tolt Watershed Management Plan;
- **Monitor forest development and disturbance in municipal watersheds** and adapt management approaches to continuously incorporate climate change impacts.

Part 2. 2025-2027 Commitments

Major Milestones	Qtly Timing
Design and install Wildfire Risk Management <b>equipment</b> , including (1) water storage tanks in municipal watersheds to provide water sources for aerial suppression tactics while preventing aquatic invasive species introductions and (2) fire suppression equipment for the Tolt Watershed, depending on grant funding or available CIP/capital expense funds.	2025 Q4
Purchase and appropriately store materials for <b>rapid post-fire response</b> , including woodstraw™ and other products to immediately treat burned hillslopes to reduce erosion and protect water quality	2025 Q2
<b>Create defensible space</b> around critical assets in municipal watersheds including water supply infrastructure, workforce facilities, pipeline and penstock rights of way, depending on grant funding or available water funds.	2025 Q4 – 2027 Q4, depending on location
<b>Implement the Cedar River Watershed Forest Management Plan (2023)</b> to achieve multiple objectives as described in the plans (separate programmatic business case).	2025-2027 (though 2050)
<b>Monitor forest development and disturbance in municipal watersheds</b> and practice adaptive management.	2025-2027 (through 2050)

### **Part 3. Racial Equity Impact**

These combined efforts reduce RSJ inequities in two ways:

1. Maintaining affordable essential services by preventing and/or reducing the risk of high consequence events that could present costly rehabilitation and restoration efforts;
2. Protecting and stewarding watershed ecosystems that provide resources of ecological and cultural significance to Tribes.

### **Part 4. Climate and Sustainability Impact**

These efforts are central to maintaining and continually improving watershed resilience in the face of increasing threats posed by climate change. Protecting the source of drinking water for the Seattle region and maintaining preparedness in the face of increasing hazards is central to SPU's mission and holistically incorporates climate change mitigation and adaptation within nature-based systems. Maintaining vigilance, preparedness, response, and continued analysis and innovation in wildfire risk management is increasingly necessary with the longer, warmer, and drier seasons that are projected in the Pacific Northwest by climate models. Monitoring and managing the forests in the municipal watersheds as the first filters for high quality drinking water provision and habitat for an array of sensitive and threatened species are critical actions for maintaining sustainability and resilience in the face of climate change.

### **Part 5. Affordability Impact**

Protecting and stewarding Seattle's mountain source watersheds carries forward a 130-year tradition for the Seattle Water System. It maintains affordability, especially with the Cedar system, by providing a pathway for filtration avoidance, thereby saving the ratepayers the cost of building filtration (potentially \$1-2 billion avoided cost). The efforts included in this initiative represent proactive and reactive strategies that can reduce the likelihood and consequence of potentially catastrophic events, such as a large wildfire.

## 9. Upstream Legislative Strategies to Reduce Pollution and Waste

<b>SBP Focus Area</b>	Stewarding Environment and Health
<b>SBP Goals</b>	Develop one water resilience from our watersheds from city to sound. Advance zero waste circular economy.
<b>SBP Strategy</b>	Reduce water, materials, and carbon pollution.
<b>Template Type</b>	Initiative
<b>SPU Branch/LOB</b>	GM's Office
<b>Executive Sponsor</b>	Andrew Lee
<b>Project Manager/Lead</b>	Yuse, Morrigan, Sukhdev, Burrell
<b>Reporting Cadence</b>	Annual
<b>Funding</b>	Baseline
<b>Last Update</b>	October 2023

### Part 1. Summary of the Initiative

SPU works with federal, state, and regional governments to advance legislation that reduces and ultimately prevents toxic chemicals, hazardous materials, and excessive waste from proliferating, ending up in the waste stream, and negatively impacting human health and the environment. SPU focuses on 'upstream' measures that prevent toxic chemicals, hazardous materials, and excessive waste from entering the economy in the first place, as opposed to later actions that simply react to the 'downstream' impacts.

In the context of our Drainage & Wastewater LoB, this means addressing emerging contaminants of concern, including PFAS, 6PPD-Q, PCBs, persistent bio-accumulative substances, and other chemicals found in stormwater and wastewater. These substances are harmful to human health and the environment.

- PFAS never break down (leading to their nickname as “forever chemicals”) and bioaccumulate in humans and animals.
- 6PPD-Q is highly toxic to Coho salmon and other types of fish.
- PCBs are highly toxic and while they are prohibited from being commercially manufactured, a loophole for “inadvertently generated PCBs” means that these chemicals continue to be found in products like yellow paint.

Many chemicals are available and used in Seattle residents’ day-to-day lives, perhaps without even knowing it. Scientists learn more about the health and safety risks of chemicals all the time, and many are found to be toxic over time. While these chemicals are ending up in our stormwater and wastewater, that is not where they originate. In Washington they are primarily found in building materials and consumer products. It is a top priority for SPU to hold companies that are distributing these chemicals responsible for their actions and prevent them from continuing to market harmful chemicals. Avoiding introducing these products into the waste stream in the first place is the most affordable way to address toxic pollution. As we build



a circular economy in Seattle, we must also make sure that the materials we are ‘circulating’ (recycling, reusing, repurposing) in our economy do not contain harmful chemicals. **We will work to pass federal, state, or local legislation that does any of the following:**

1. Bans harmful chemicals from production, inclusion, or sale in products;
2. Requires producers to find safer alternatives to toxic chemicals;
3. Holds producers financially accountable for producing toxic chemicals;
4. Anything else to reduce the amount of toxic chemicals from entering stormwater or wastewater.

**We will work to secure federal, state, or local funding that does any of the following:**

1. Funds projects and initiatives to remove toxic chemicals like PCBs from historic sources;
2. Raises public awareness about hazards of chemicals in consumer products;
3. Funds research into safer alternatives or mitigation of chemicals.

One excellent example is Washington’s Producer Responsibility program for pharmaceuticals. Before the program was established, residents did not have a way to properly dispose of their unused medications, leading to commonly flushing them down the toilet. Drugs ending up in wastewater is hazardous to public health and the environment. In response, the legislature tasked pharmaceutical companies (the producers of drugs) with taking back their product and disposing of them safely. SPU supported this effort and continues to support legislation like this.

There are many opportunities to reduce waste and carbon pollution from a Solid Waste perspective. Washington State has several Extended Producer Responsibility (EPR) Programs which shift the burden of responsibility for disposing of hazardous materials like fluorescent lightbulbs and paint onto producers of those products. These programs help keep our wastewater stream cleaner while also increasing recycling and reducing waste. As part of our zero-waste, one water mission, SPU supports EPR programs, including but not limited to: light bulbs, sharps, appliances, and paper and packaging. **Government relations staff, policy staff, and leadership will work with state legislators and collaborate with other levels of government to extend, expand, and/or establish producer responsibility programs.** SPU supports other legislation that reduces waste including right to repair and product bans that extend the life of existing items or removes problematic materials from the waste stream.

Across each of these upstream legislative approaches, we will put pressure on producers and industry groups to move towards easier to recycle, less toxic materials.

**Part 2. 2025-2027 Commitments**

Major Milestones	Qtly Timing
Implement legislative strategy on 6PPD-Q	2030
Implement legislative strategy on PFAS	2030
Pass legislation to reduce and divert solid waste from landfills	2030

### **Part 3. Racial Equity Impact**

Data shows that historically marginalized populations including Black, Indigenous, and People of Color as well as low-income families are frequently exposed to more toxins, making addressing contaminants of concern both a climate justice and environmental justice issue.

Producer Responsibility Programs include additional education and outreach to improve recycling services for underserved communities. Programs are also structured to provide better, more accessible service for all households.

### **Part 4. Climate and Sustainability Impact**

Increasing recycling reduces reliance on virgin products which have a higher carbon footprint. For paper and packaging specifically, recycling avoids three tons of climate pollution for every ton recycled. EPR programs also aim to reduce the use of excessive packaging and other products through tiered fee structures. This further reduces reliance on virgin products.

### **Part 5. Affordability Impact**

Upstream legislative solutions like producer responsibility shifts the costs of dealing with hazardous and difficult-to-manage materials onto producers. Right now, local governments and utilities are grappling with the expense and difficulty of managing these materials. Reducing costs of the system will keep SPU's rates more affordable. Similarly, bans or limits on toxic chemicals in products can reduce the cost of managing the negative impacts of these substances in our waste stream.

For example, 6PPD-Q is a byproduct of a chemical used in tires and is therefore found on roads. Right now, the City's tools for preventing 6PPD-Q from running into streams are limited, expensive, and have marginal benefits on the large scale (i.e. installing green stormwater infrastructure, road sweeping). With upstream solutions like a ban on 6PPD, this toxic chemical would be significantly less prevalent on our roads, and we could focus resources elsewhere.

## 10. 2030 Carbon Neutrality and Sustainable Operations

<b>SBP Focus Area</b>	Stewarding Environment and Health; Strengthening Our Utility’s Business Practices
<b>SBP Goals</b>	Develop One Water resilience from our watersheds to city to Sound; Advance Zero Waste Circular Economy; Manage assets and risks optimally; Foster a culture of shared leadership, continuous improvement, and innovation.
<b>SBP Strategy</b>	Reduce materials and prevent water and carbon pollution; Support a continuous improvement and innovation culture
<b>Template Type</b>	Initiative
<b>SPU Branch/LOB</b>	General Manager’s Office – Corporate Policy & Planning
<b>Executive Sponsor</b>	Andrew Lee
<b>Project Manager/Lead</b>	Danielle Purnell
<b>Reporting Cadence</b>	Annual
<b>Funding</b>	Requesting \$100k/year in O&M and \$350k/year in Capital
<b>Last Update</b>	September 2023

### Part 1. Summary of the Initiative

The Utility is facing a challenging future as it responds to the impacts of climate change and works to reduce greenhouse gas emissions in operations. Driven by our own motivation to steward the environment and public health and strengthen our utility’s business practices, as well as multiple Executive Orders focused on climate mitigation, SPU has laid out long-term climate mitigation, energy management, and resource conservation goals for our own operations, facilities, and activities. SPU aims to be carbon neutral by 2030 and resource efficient in our operations, while actively exploring opportunities to generate renewable energy and other innovations. SPU also has an obligation to approach procurement and purchasing in an environmentally sustainable way.

This work will be led and coordinated by the Corporate Policy & Planning team in partnership with SPU Logistics. The initiative will:

- Develop and implement SPU’s Renewable Energy Strategy
  - In-Line Hydropower (producing renewable energy from excess pressure in our drinking water pump systems)
  - Solar power (installing solar panels on appropriate SPU facilities)
  - Sewer Heat Recovery (capturing heat energy from sewer pipes to heat or cool buildings)
- Enhance coordination and understanding of water-energy nexus opportunities with Seattle City Light including joint conservation opportunities for Seattle residents and businesses
- Lead and coordinate SPU’s Green Purchasing, Procurement, Contracting implementation strategy

- SPU purchases (from office supplies to flatware used for meetings/events to office furniture)
- Capital projects (the materials going into our infrastructure, our construction processes)
- End-of-life asset management (what happens to our equipment, infrastructure, and buildings when they reach end of life)
- Develop projects and programs that drive resource conservation in our operations
  - Energy efficiency / fuel efficiency assessments and implementation
  - Water conservation and reuse
  - Waste prevention
- Support the delivery of SPU’s Fleet and Facility Electrification Strategy
  - Green New Deal Building Electrification
  - Green Fleet Electrification / Emissions reductions
  - Additional Electrification Projects (e.g. Leaf blowers)
- Report and track greenhouse gas emissions, energy usage, and SPU’s *carbon neutral by 2030* target
  - Develop energy, fuel, water, waste dashboard + benchmark reports for operational/ frontline staff and leadership
  - 2024 to 2030 annual operational GHG inventory reports
  - SPU Climate Action Roadmap: Reporting on pathways to SPU’s Carbon Neutral by 2030 target
- Research carbon offset market and identify SPU’s needs for carbon offset purchases
- Pursuit of external funding and partnerships to support these activities (Climate Commitment Act, Clean Fuel Program, IRA, etc.)

**Part 2. 2025-2027 Commitments**

Major Milestones	Qtly Timing
2024 GHG Inventory Annual Reporting Complete	Q3 2025
2025 GHG Inventory Annual Reporting Complete	Q3 2026
2026 GHG Inventory Annual Reporting Complete	Q3 2027

**Part 3. Racial Equity Impact**

- **Equity is a strong motivating factor behind SPU’s efforts around climate mitigation** - climate impacts in Seattle will disproportionately burden already marginalized communities, and SPU should fulfill its civic responsibility to lead by example in reducing emissions
- **The identification, prioritization & implementation of all energy efficiency, renewable energy, electrification, resource conservation, green purchasing & procurement, and other emissions reductions efforts should take an equity lens** in considering potential impacts to different groups, and ensuring stakeholders are engaged appropriately. Race and Social Justice (RSJ) assessments will be completed as part of the initiation phase of

programs/projects and if it is determined that the RSJ impact will be significant, we will apply the Racial Equity Toolkit to reduce the RSJ impacts. For example, this work will focus on SPU facilities located in areas that are already experiencing poor air quality.

- **Actions that can support marginalized voices and directly benefit target communities** should be prioritized (e.g., blue and green job programs, contracting with WMBE organizations). This position is expected to work closely with the SPU Economic Opportunities Advisor/WMBE Advisor position and SPU Contracts and Procurement Division to advance equity in green procurement opportunities.

#### **Part 4. Climate and Sustainability Impact**

The primary purpose of this initiative is to mitigate the climate and environmental impacts of our operations. By reducing the greenhouse gas emissions in our operations, effectively finding ways to conserve energy and water, and preventing waste, this initiative will make operations more sustainable. In addition, investments in renewable energy and efforts to ‘green’ our purchasing and procurement processes will both have positive environmental impacts for Seattle.

#### **Part 5. Affordability Impact**

Efforts that aim to manage our resource consumption (i.e. water, energy, materials) will result in financial savings for the utility (e.g. electricity, fuel and gas bills reduced due to energy efficient efforts, reduction in electricity bills due to renewable energy net metering). Managing the costs of our operations and the effective management of our assets contributes to ratepayer affordability. In some cases, projects and investments may result in increased costs initially or in a transition period (e.g. upfront investment in renewable energy installation, increased electricity bills due to fleet and facility electrification) but we expect these to be offset by reductions in other costs (e.g. fossil gas bills, fuel bills) and new sources of revenue (e.g. electricity generation).

## 11. Waste Prevention and Diversion

<b>SBP Focus Area</b>	Stewarding Environment and Public Health
<b>SBP Goals</b>	Advance Zero Waste
<b>SBP Strategy</b>	Reduce Materials and Carbon Pollution
<b>Type</b>	Investment
<b>SPU Branch/LOB</b>	Solid Waste/Solid Waste Planning & Program Management
<b>Executive Sponsor</b>	Jeff Fowler
<b>Project Manager/Lead</b>	Dependent on Project/Pilot (see below)
<b>Reporting Cadence</b>	Quarterly or Annually (Dependent on investments)
<b>Funding</b>	Dependent on Project/Pilot (see below)
<b>Last Update</b>	September, 2023

This investment category is comprised of multiple programs in three grouping defined by funding status:

### ***Sub-Investments Include:***

- A. Food Waste Reduction & Equitable Compliance Enforcement
- B. Reuse Seattle Investment – Reusable Foodservice Ware Initiative

### ***Placeholder Funding Sub-Investment Include:***

- C. Waste Prevention Strategic Plan Support & Implementation

### ***Grant-dependent Sub-Investments Include:***

- D. Construction & Demolition (C&D) Reuse Events at Transfer Stations
- E. C&D Salvage Lumber Warehouse Support

**Overall Summary:** The five programs described below continue the City’s investment in Diverting solid waste from disposal and increasing our investment in Waste Prevention, which is key to achieving our Zero Waste goal and reducing materials and carbon pollution. The first two are priority investments that focus on the 1) Food Waste Reduction & Equitable Compliance Enforcement and 2) Reuse Seattle’s Reusable Foodservice Ware Initiative, the third highlights where we are going as we complete the Waste Prevention Strategic Plan over the next two years and in move into implementation in approximately 2026, which may require new investments, and the last two relate to C&D Reuse Events and C&D Salvage Lumber Warehouse Support, which are dependent on the receipt of grant funding, both state and federal.

## **SUB-INVESTMENT A: FOOD WASTE REDUCTION & EQUITABLE COMPLIANCE ENFORCEMENT**

### **Part 1. Summary of Sub-Investment A**

**Project Leads – Solid Waste Planning & Program Management (SWPPM) Staff (Cross-divisional)**

Preventing food from being wasted or landfilled is the single most impactful step that SPU can take to mitigate climate change.<sup>1,2</sup> In fact, food is the second largest contributor (23.7%) to consumption-based greenhouse gas (GHG) emissions in Seattle after transportation (30.9%).<sup>3</sup> In addition, SPU must meet food waste-related goals and commitments laid forth in the SPU SBP (2021-2026), the 2022 Solid Waste Plan, the City of Seattle Climate Action Plan (2013), and the City of Seattle Food Action Plan (2022), as well as comply with the new [WA State Organics Management Law](#) (HB 1799 2022). This state law aims to cut landfill-disposed organic material by 75% by 2030 compared to 2015 levels and includes phased requirements for services and programs to divert food waste from landfill disposal and increase food waste prevention and food rescue.

Although Seattle already has policies in place prohibiting food in the garbage and programs to support food waste prevention and diversion, food waste remains the single largest component in Seattle's residential and commercial garbage streams and the majority of it is edible food waste.<sup>4,5</sup> Seattle residents are currently only diverting about one-third of all food waste to the compost stream, while the other two-thirds are going to the garbage, which is in direct violation of City code. In addition, in SPU's 2022 Commercial Garbage Waste Composition Study, food waste accounts for nearly 20% of garbage generated by businesses, with 71% of that food waste being edible.

Therefore, SPU needs further investment to meet its established commitments, support the implementation of state law, and achieve meaningful food waste reduction in Seattle. This Investment supports SWPPM staff to deploy a coordinated and holistic approach to food waste prevention and diversion focused on compliance enforcement and behavior change. This investment will also be used in the following ways, creating a cross-divisional, coordinated team of staff and consultants to address the above needs:

- **Hire an FTE Solid Waste Planning & Development (SW P&D), Spec II to:**
  - Focus on the largest generators of food waste in the commercial and residential sectors, including customers with garbage compactors;<sup>6</sup> and,
  - Carry out compliance audits and enforcement of the City's ban on food waste disposal (SMC 21.36.082-083).

The role of this SW P&D, Spec II is essential to make SPU's enforcement of solid waste requirements equitable, as SPU currently cannot evaluate garbage compactors with current staffing and resource levels; therefore, we aren't able to assess these customers'

---

<sup>1</sup> Project Drawdown, <https://drawdown.org/solutions/table-of-solutions>

<sup>2</sup> U.S. EPA, [From Farm to Kitchen: The Environmental Impacts of Food Waste](#), November 2021.

<sup>3</sup> City of Seattle, [Seattle Communitywide Consumption-based GHG Emissions Inventory](#), Prepared by EcoDataLab and Stockholm Environment Institute, February 2023.

<sup>4</sup> Seattle Public Utilities, [2020 Residential Waste Composition Study](#), Prepared by Cascadia Consulting Group.

<sup>5</sup> Seattle Public Utilities, [2022 Commercial Waste Composition Study](#), Prepared by Cascadia Consulting Group. (Unpublished Draft)

<sup>6</sup> Garbage compactors are used by some of the largest multifamily and businesses. While only 8% of multifamily buildings use them, they account for 40% of all apartment units.

compliance. Audits will be used to identify non-compliant customers, and enforcement-backed notifications will connect customers to existing SPU outreach programs.

- **Hire a TES SW P&D, Spec II to:**
  - Manage the consultant hiring;
  - Manage the consultant contract(s); and,
  - Assist in the work with both the residential and commercial sectors.
  
- **Hire Consultants to:**
  - Conduct research into the barriers and motivations for food waste prevention and diversion in the Seattle residential sector, with a special focus on the multifamily sector;
  - Assist in the design and implementation of multiple campaign tactics based on research to improve both food waste prevention and diversion;
  - Evaluate the success of those tactics;
  - Assist in the scaling up of commercial-sector engagement and action related to food waste prevention through partnerships, campaigns, and sector-specific technical assistance;
  - Help with the development of measurement and evaluation tools to track prevention progress across commercial sectors;
  - Assist with commercial sector compliance audit effort; and,
  - Support the coordination and management of associated datasets, process flows, and field activities.

**Part 2. Targeted Commitments and Performance Measures for Sub-Investment A**

Major Milestones	Anticipated Outcomes	Timing
Scoping & Staffing	<ul style="list-style-type: none"> <li>● Hire SW P&amp;D, Spec II to perform compliance audits and enforcement work.</li> <li>● Hire TES SW P&amp;D, Spec II to manage behavior change research and campaign, including managing the consultant contract.</li> <li>● Hire consultants to support behavior change research and campaigns, commercial sector technical assistance, and compliance audits.</li> </ul>	2025
Preliminary Compliance Activity	<ul style="list-style-type: none"> <li>● Pilot compactor compliance audits and enforcement work.</li> <li>● Conduct follow-up with stakeholders and update approach based on feedback.</li> <li>● Determine how frequently each building needs to be re-audited.</li> </ul>	2025



Major Milestones	Anticipated Outcomes	Timing
Broad Compliance Activity	<ul style="list-style-type: none"> <li>Conduct audits in all buildings with garbage compactors.</li> <li>Track selected compactors from source of origin to transfer stations, conducting spot checks and waste composition reviews.</li> <li>Conduct re-audits of sites on a cycle TBD.</li> </ul>	2026 onward
Targeted Commercial Engagement	<ul style="list-style-type: none"> <li>Scale up sector-specific engagement and partnerships to reach large generators of food waste.</li> <li>Provide technical assistance to support food waste prevention actions.</li> </ul>	2025-2028
Behavior Change Campaign Research & Planning	<ul style="list-style-type: none"> <li>Research the primary barriers and motivations for residential food waste reduction.</li> <li>Develop campaign tactics to increase food waste prevention and diversion.</li> </ul>	2026
Campaign Implementation	<ul style="list-style-type: none"> <li>Implement recommended behavior change campaign tactics across the City or for targeted audiences per research recommendations.</li> </ul>	2027-2028
Evaluation	<ul style="list-style-type: none"> <li>Conduct waste audits and other research to evaluate the success of the implemented tactics and programs and determine future actions.</li> </ul>	2029-2030

### **Part 3. Financial Summary of Sub-Investment A**

Program Title	Food Waste Reduction & Equitable Compliance Enforcement (\$000's)						
Project Name	Various						
	2025	2026	2027	2028	2029	2030	TOTAL
Baseline – O&M – Solid Waste P&D Spec II	173	179	186	201	209	218	1,166
Baseline - O&M – TES P&D Spec II	161	167	174	181	188	195	1,066
Baseline – O&M – Consultant Services, etc.	300	320	340	360	380	400	2,100
<b>Total Baseline</b>	<b>634</b>	<b>666</b>	<b>700</b>	<b>742</b>	<b>777</b>	<b>813</b>	<b>4,332</b>

An investment that succeeds in reducing food waste through both prevention and diversion will ultimately help our customers save money and provide a significant return on investment. Global studies show for every \$1 invested in prevention, businesses recover \$7 in return. Consumers are currently estimated to waste 25% of the food they purchase, so can realize substantial monthly savings on food bills when they prevent food from going to waste.

Additionally, as SPU customers prevent or divert more food waste from the garbage, it is expected that their monthly solid waste bills can potentially decrease if they are able to downsize their garbage container size or pick-up frequency.<sup>7</sup> Finally, given that food waste makes up a significant portion of the garbage generated by both Seattle residential and business customers, reducing the amount of food waste being placed in the garbage may reduce SPU's long-term disposal costs.

One option for covering the cost of hiring a permanent Solid Waste P&D, Spe II position is to increase the garbage rates specifically for customers with garbage compactors. Currently, SPU's garbage collection rates offer a large [financial incentive for customers to use garbage compactors](#), and even with a modest rate increase, compactor rates would likely remain significantly lower than dumpster rates. While compactors are a good solution for many buildings due to space and access constraints, SPU needs to be able to audit them to be equitable with respect to enforcement of solid waste compliance requirements and incorporating the cost of those audits into the compactor service rates would be a fair way to pay for that service need.

#### **Part 4. Capacity Plan to Deliver (Existing/Capital Only) Sub-Investment A**

While SPU currently has staff working on both residential (Single-family and Multifamily) and commercial customer outreach, educational, and technical assistant needs involving organics generally, along with staff that conduct inspections, we do not currently have resources dedicated specifically to this area of food waste reduction and equitable compliance enforcement. Some of the resources currently dedicated to the *Love Food, Stop Waste* program, as well as other current food reduction education efforts would be merged into this effort, supporting the holistic and cross-divisional approach to this issue.

#### **Part 5. Racial Equity Impact of Sub-Investment A**

The primary climate pollutant associated with food waste, methane, is a short-lived greenhouse gas whose impacts are associated with the most immediate impacts of climate change. To strategically reduce these most immediate impacts while longer-term strategies are taking place, states like CA and WA are requiring increased diversion of food waste from landfills and prevention of edible food waste. Communities of color and economically disadvantaged communities are recognized as those most affected by climate change, and we need to take action to protect these communities from the effects of climate pollution. Moreover, we know from our waste composition studies that multifamily residents are experiencing the most challenges in diverting food waste. We also know that economically challenged residents are more likely to live in multifamily housing. This project will center on environmental justice and helping those who need it most.

---

<sup>7</sup> SPU's collection rates are set up to incentivize diversion, hence customer's solid waste monthly charges are mainly due to garbage collection (recycling collection is embedded in the garbage collection rates and provided to customers at no additional charge and food/yard waste collection is affordable).

In addition, SPU needs to equitably enforce solid waste requirements. Currently, SPU does not have a mechanism to audit customers with garbage compactors, only customers with garbage dumpsters are audited. As a result, customers with garbage compactors receive preferential treatment on two fronts: 1) they pay much less for garbage collection than customers with dumpsters, and 2) they are not subjected to solid waste compliance evaluation audits and subsequent enforcement action.

#### **Part 6. Climate and Sustainability Impact of Sub-Investment A**

As noted in Sub-Investment 1 – Part 5, the primary climate pollutant associated with food waste, methane, is a short-lived greenhouse gas whose impacts are associated with the most immediate impacts of climate change. Methane has more than 80 times the warming power of carbon dioxide over the first 20 years after it reaches the atmosphere. The diversion of food waste from landfills and prevention of edible food waste is a critical element to managing our impacts on the climate and promoting sustainability.

#### **Part 7. Affordability Impact of Sub-Investment A**

As noted in Sub-Investment 1 – Part 5, SPU does not have a mechanism to audit customers with garbage compactors, only customers with garbage dumpsters are audited – creating an inequitable system for those with dumpsters. Customers with garbage compactors receive preferential treatment on two fronts: 1) they pay much less for garbage collection than customers with dumpsters, and 2) they are not subjected to solid waste compliance evaluation audits and subsequent enforcement action. We also know that economically challenged residents are more likely to live in multifamily housing with dumpsters.

#### **Part 8. Alternatives and Options to Consider for Sub-Investment A**

- **Proposed Investment above:** Implement a strategic and holistic approach to reduce food waste with the additional resources described above in detail, which is needed to scale and sustain activities City-wide using equitable and effective tactics.
- **Status quo:** Continue with our current programs, which are not resourced at a level to enable comprehensive and equitable engagements with Seattle residents and key commercial sector generators. This will jeopardize SPU’s ability to comply with state law and to follow through on its goals and commitments related to reducing food waste and realizing climate change mitigation. Specifically, regarding food waste diversion, we believe that the status quo poses risk of failing to make meaningful progress, as the sector most challenged with food waste diversion is multifamily, where most of the expected 250,000 new residents arriving in the next 20 years will live.

### **SUB-INVESTMENT B: REUSE SEATTLE – REUSABLE FOODSERVICE WARE**

#### **Part 1. Summary of Sub-Investment B**

##### **Project Leads – SWPPM Staff, with support from Staff in Corporate Policy**

In 2021, SPU launched Reuse Seattle ([www.reuseseseattle.org](http://www.reuseseseattle.org)), a city-led initiative to help Seattle move from single-use to reusable foodservice ware. This initiative has multiple benefits for SPU customers: it significantly reduces the amount of waste and associated environmental impacts

generated from foodservice activities; better facilitates food waste diversion in foodservice settings; and, reduces the likelihood of contamination in both the recycling and organics streams. In certain applications, transitioning to reusable foodservice ware can result in significant cost savings for businesses over time. Reusable foodservice ware systems can also contribute to economic development, creating local jobs and supporting local businesses. SPU has already committed to working to support the transition from single-use to reusable foodservice ware in Seattle under the 2022 Solid Waste Plan and the City of Seattle Food Action Plan (2023). Reuse Seattle is a strategic initiative in SPU's work to help transition Seattle to a more circular economy and achieve Zero Waste.

Interest and funding for reusable foodservice ware systems is growing rapidly, and SPU is attracting substantial attention for our leadership and investment in this area. We anticipate that SPU, through the Reuse Seattle initiative, will be able to secure outside funding in the coming years to support a range of activities under this initiative. For example, we have already secured \$225,000 in funding from the Seattle Office of Economic Development (OED) for the 2023-2024 period to support the implementation of a reuse rebate program to help Seattle foodservice businesses cover the upfront costs of replacing single-use items with reusable alternatives. Additionally, we are aware of multiple federal, state, and private sector funding opportunities that will become available to support initiatives like Reuse Seattle in the next few years.

However, to take advantage of this enormous potential, SWPPM needs dedicated staff support to secure and oversee these funds, carry out and manage funded activities, and serve as a liaison to and nurturing the relationships with our Reuse Seattle partners. To date, the Reuse Seattle initiative has been supported using a portion of the time of the Commercial Recycling & Composting Program Manager, two Strategic Advisors (Circular Economy and Waste Prevention), and an additional temporary staff support of a 0.5 TES, which sunsets in mid-2024. In addition, Reuse Seattle received temporary supplemental funding added to the Green Business Program budget for the 2021-2022 and 2023-24 budget cycles that have supported consultant services to help carry out activities.

This Investment will provide a dedicated full-time TES SW P&D, Spec II to support Reuse Seattle for the 2025-2027 timeframe.

**Part 2. Targeted Commitments and Performance Measures for Sub-Investment B**

Major Milestones	Anticipated Outcomes	Timing
Staffing & Funding	<ul style="list-style-type: none"> <li>Hire a TES SW P&amp;D Spec II to support Reuse Seattle Initiative</li> <li>Pursue and secure external funding to provide additional support for Reuse Seattle activities</li> </ul>	2025
Implementation	<ul style="list-style-type: none"> <li>Carry out and manage Reuse Seattle activities, such as:                             <ul style="list-style-type: none"> <li>Extension and expansion of Reuse Rebate Program (currently funded by OED)</li> <li>Development and support of public place collection network</li> <li>Targeted engagement and support for reuse at special events</li> </ul> </li> </ul>	2025-2027
Evaluation	<ul style="list-style-type: none"> <li>Assess and quantify impact of Reuse Seattle initiative</li> <li>Develop a need/value proposition for staff support.</li> <li>Make recommendations for staffing and/or investments levels in future years</li> </ul>	2026-2027

**Part 3. Financial Summary of Sub-Investment B**

Program Title	Reuse Seattle – Reusable Foodservice Ware Initiative (\$000's)						
Project Name	Various						
	2025	2026	2027	2028	2029	2030	TOTAL
Baseline O&M - TES, P&D Spec II	161	167	174				502
Baseline – Capital	N/A	N/A	N/A	N/A	N/A	N/A	N/A
<b>Total Baseline</b>	<b>161</b>	<b>167</b>	<b>174</b>				<b>502</b>

**Part 4. Capacity Plan to Deliver (Existing/Capital Only) Sub-Investment B**

The Reuse Seattle TES employee will have access to limited funding to deliver the program under the Green Business Program non-labor budget. Additional funding for program delivery is anticipated to come from multiple federal, state, and private sector funding opportunities. Funding for the TES is anticipated to come from half from the current base budget (i.e., ending of the current 0.5 TES working on WP Strategic Plan) and the other half from new investment.

**Part 5. Racial Equity Impact of Sub-Investment B**

Through Reuse Seattle, SPU is committed to advancing a vision that brings reusable foodservice ware to residents and businesses in all parts of our community and we are committed to ensuring that our approach prioritizes reuse systems that are equitable in access and affordability. Without SPU leadership in this area, reusable foodservice ware systems may

emerge that are available only to those who can afford to pay a premium, and as a result may not equitably serve Seattle’s minority-owned businesses or may exclude certain neighborhoods or communities.

#### **Part 6. Climate and Sustainability Impact of Sub-Investment B**

Reusable foodservice ware is designed to be used multiple times, for its original intended purpose, as part of a dedicated system for reuse. When scaled effectively, reusable systems offer smaller material and emissions footprints compared to traditional single-use foodservice ware. Through Reuse Seattle, SPU is committed to advancing a vision that brings reusable foodservice ware to residents and businesses in all parts of our community and we are committed to ensuring that our approach prioritizes reuse systems that are equitable in access and affordability. Without SPU leadership in this area, reusable foodservice ware systems may emerge that are available only to those who can afford to pay a premium, and as a result may not equitably serve Seattle’s minority-owned businesses or may exclude certain neighborhoods or communities.

#### **Part 7. Affordability Impact of Sub-Investment B**

As noted in Sub-Investment 2 – Part 5 above, Reuse Seattle, SPU is committed to advancing a vision that brings reusable foodservice ware to residents and businesses in all parts of our community in an equitable and affordable manner. SPU’s leadership in this area, is critical to ensure that reusable foodservice ware systems emerge that are available and affordable to all, and that Seattle’s minority-owned businesses or residents from certain neighborhoods or communities are not excluded.

#### **Part 8. Alternatives and Options to Consider for Sub-Investment B**

- **Proposed Investment above:** Add functional equivalent of 0.5 TES SW P&D, Spec II to expand SPU’s capacity to advance and grow the Reuse Seattle Initiative.
- **Status quo:** Lose 0.5 TES mid-2024, who currently provides support to Reuse Seattle. As a result, remaining staff will have diminished capacity to support transition from single-use to reusable foodservice ware and SPU will risk missing the opportunity to take advantage of the multiple federal, state, and private sector funding opportunities that will become available to support initiatives like Reuse Seattle in the next few years. In addition, the reduction in waste generation that a reuse economy promises will be take significantly longer.

### **SUB-INVESTMENT C: WASTE PREVENTION STRATEGIC PLAN SUPPORT & IMPLEMENTATION (PLACEHOLDER FUNDING)**

#### **Part 1. Summary of Sub-Investment C**

##### **Project Lead – SWPPM Staff**

SPU is an internationally recognized leader in recycling and composting, having worked for decades to build a strong diversion ethic for recyclables and organics in Seattle. As work

continues to maintain and grow that ethic and associated behaviors, SPU is looking to a similar leadership role with significant benefits by building a comparable ethic of waste prevention in Seattle. Waste prevention (WP) is widely recognized as the cornerstone to addressing waste and its impacts, yet there have been relatively few resources invested in cohesive planning and programs by Seattle or other governments. There is an urgent need for Seattle to lead on WP. WP as a key strategy for SPU is particularly important as we face challenges with changing recycling markets and issues around the proliferation of single-use plastics. It's also the most effective way for us to combat climate change within the materials management field.

In Seattle's 2022 Solid Waste Plan Update: Moving Upstream to Zero Waste, SPU has highlighted WP as a key priority. By end of 2025, our objective is to have a well-formulated WP Strategic Plan and Implementation Plan in place that clearly defines:

- WP goals, prioritization criteria, and metrics that reflect community interests;
- WP program and policy priorities that will allow SPU to most effectively leverage its unique role to amplify existing WP resources, support new community-led solutions, incentivize WP, and reduce or eliminate barriers to preventing waste; and,
- Strategies and tools to measure success.

Beginning in 2026, SPU aims to conduct ongoing WP Strategic Plan implementation, oversight, and measurement to monitor progress towards achieving our established goals.

The current SPU Waste-free Community Grants are an example of a program that is tied into the outcomes of the WP Strategic Plan recommendations. Based on the results of the WP Strategic Plan, the grant program may then be canceled with funds and staffing reallocated to other priorities or potentially expanded or modified to better reflect community needs.

To make progress on WP in Seattle and become a national leader, SPU will need additional FTE and non-labor resources allocated to the implementation of the WP Strategic Plan recommendations. While we are not able to know specific budget and staffing needs until the WP Strategic Plan is complete, we can use knowledge from our current WP programs and what other jurisdictions are doing to provide an estimate.

For example, much of the opportunity for expanding WP in Seattle will likely involve investing in community-led solutions through a grant program similar to the Waste-free Community Grant Program we are currently running or other types of investments. SPU's current Waste-free Community Grants Program funds \$200,000 in awards spread over 2-years, averaging \$100,000 annually with \$40,000 maximum per award. We received 44 applications for the 2023-2025 grant cycle for a total request of \$1.5 million. Examples of investment opportunities from this grant cycle include:

- Test reusable packaging options for product shipping and delivery
- Establish a community hub to provide a suite of complementary WP services, such as a tool library, repair space, and second use building supplies store
- Identify solutions and infrastructure for the repair and reuse of uniforms

- Provide culturally relevant WP education and resources for immigrant and refugee communities
- Install water refill stations to reduce single-use water bottles
- Collect, repair, and refurbish damaged furniture for donation to recent immigrant and low-income families
- Expand apps that help people and organizations share outdoor gear and other materials
- Grow small businesses that upcycle textile waste into new quality products

This grant program not only supports WP efforts and innovations but invests in our community in ways that support innovation and job creation – going directly to SPU’s vision of Community-Centered. \$100,000 annually is not adequate to meet community needs and we must decline many promising WP investment opportunities. Other jurisdictions offer larger funding amounts for similar grant efforts, such as \$300,000 annually for King County grants, \$800,000 annually for Alameda County (CA) grants, and \$2 million annually for Portland Metro grants.

In addition to direct investment, we anticipate there will be other roles SPU is well positioned to take on to support community-led solutions to WP. For example, promoting WP resources available in the community, convening stakeholders to solve challenges and leverage resources, and developing new policies.

Based on the above, we anticipate implementation of the WP Strategic Plan will require an additional 1.0 FTE P&D, Spec II and additional funding for grants and services from 2025-2030.

**Part 2. Targeted Commitments and Performance Measures for Sub-Investment C**

Major Milestones	Anticipated Outcomes	Timing
WP Strategic Plan	<ul style="list-style-type: none"> <li>• WP goals, prioritization criteria, metrics, and measurement and evaluation approaches that guide how we prioritize resources for WP moving forward</li> </ul>	2024
WP Implementation Plan	<ul style="list-style-type: none"> <li>• Specific short-term and long-term WP program and policy priorities to help SPU achieve the goals and metrics identified in the WP Plan</li> </ul>	2025
Measurement tools	<ul style="list-style-type: none"> <li>• Tools, such as models, surveys, etc. that will help SPU measure progress towards the WP Strategic Plan goals and metrics</li> </ul>	2025
WP Strategic Plan collateral and outreach	<ul style="list-style-type: none"> <li>• Videos, graphics, and other communication tools developed and shared with the community describing the WP Strategic Plan</li> </ul>	2025
2025-2027 SPU waste-free community grants	<ul style="list-style-type: none"> <li>• Funding awarded to support community-led WP solutions</li> </ul>	2025
P&D, Spec II hired	<ul style="list-style-type: none"> <li>• Staff hired to support the implementation of the WP Strategic Plan implementation starting in 2026</li> </ul>	2025 - 2026



Major Milestones	Anticipated Outcomes	Timing
Baseline measurement	<ul style="list-style-type: none"> <li>Baseline established to measure against for assessing progress towards the WP Strategic Plan goals and metrics</li> </ul>	2026
Priority WP program and policy Implementation	<ul style="list-style-type: none"> <li>Development and implementation of the program and policy priorities identified in the Implementation Plan</li> </ul>	2026-2030
Ongoing measurement	<ul style="list-style-type: none"> <li>Measure annual progress towards the WP Strategic Plan goals and metrics</li> </ul>	2027-2030

### **Part 3. Financial Summary of Sub-Investment C**

Program Title	Waste Prevention Strategic Plan Support & Implementation (\$000's)						
Project Name	Various						
	2025	2026	2027	2028	2029	2030	TOTAL
Baseline – O&M – FTE SW P&D, Spec II		179	186	201	209	218	993
Baseline – O&M – Services	150	300	350	400	450	500	2,150
Baseline –Capital	N/A	N/A	N/A	N/A	N/A	N/A	N/A
<b>Total Baseline</b>	<b>150</b>	<b>479</b>	<b>536</b>	<b>601</b>	<b>659</b>	<b>718</b>	<b>3,143</b>

#### Assumptions:

- 4% annual inflation
- 1.0 FTE SW P&D, Spec II (expenses starting in 2026)
- \$150,000 in 2025 to support the development of the Implementation Plan and measurement and communication tools
- \$300,000 in 2026 (\$100K to supplement baseline measurement + \$200K for priority program/policy development)
- 2027 reflects ramping up the implementation of priority programs and policies; 2028-2030 reflect full implementation

Most of the requested funds will be reinvested in the community through grant funding, promoting, or otherwise supporting community-led solutions to WP. As evidenced in SPU's Waste-free Community Grants Program, reinvesting in the community creates jobs, helps small businesses grow, and helps customers save money through activities such as buying less, reuse, repair, repurpose, and sharing resources in the community. SPU currently allocates a 1.0 FTE P&D, Spec Sr. to manage the WP Strategic Plan development effort and the Waste-free Community Grants Program. Starting in 2026, this FTE will be reallocated to WP Strategic Plan implementation and measurement. We are requesting an additional 1.0 FTE P&D, Spec II starting in 2026 to support WP Strategic Plan implementation based on the anticipated larger scale of community investments.

#### **Part 4. Capacity Plan to Deliver (Existing/Capital Only) Sub-Investment C**

SPU currently allocates \$110,000 annually (O&M) for the Waste-free Community Grants Program (\$100,000 for awards and \$10,000 for outreach and translation). These funds will be reallocated to the WP Strategic Plan implementation starting in 2026.

SPU's current budget for the WP Strategic Plan research, development, and measurement is \$288,000 annually (O&M). Our intention is to reserve these funds for ongoing WP measurement and plan updates. Allocating funds towards good measurement has been a key component of SPU's success as a leader in the diversion of recyclables and organic materials from landfill. We anticipate measurement will also be key to our success as a leader in WP.

#### **Part 5. Racial Equity Impact of Sub-Investment C**

WP has many community benefits, such as providing free and low-cost resources (e.g., food, clothing, furniture, outdoor gear, etc.) to low-income communities and people experiencing homelessness. There are also some potentially negative equity considerations when it comes to cost, such as spending more upfront on higher quality clothing that will last longer, or repairing something that can be purchased inexpensively new. These are the types of issues we are considering as we develop our WP Strategic Plan.

The WP Strategic Plan will become the guiding document on how SPU prioritizes resources for WP moving forward. As such, we are conducting an extensive community involvement process to guide the development of the WP Strategic Plan. Our RSJ consultant for the project has led us in developing an RSJ Framework for the planning effort. The framework prioritizes meaningfully involvement of Black and Indigenous communities, immigrant and refugee populations, elders, people with disabilities, low-income communities, and people experiencing homelessness. It emphasizes not only looking for barriers and gaps, but also for opportunities to share the WP wisdom and behaviors already practiced in communities. They will analyze the data and recommendations that come from the planning effort with an equity lens, and guide SPU in making decisions on goals, prioritization criteria, metrics, priority programs and policies, and measurement and evaluation tools and strategies. SPU's effort to develop an equitable WP Strategic Plan is the foundation that will help drive equity in our WP implementation efforts as well.

#### **Part 6. Climate and Sustainability Impact of Sub-Investment C**

WP is the foundation to supporting a circular economy and addressing the negative climate impacts of a linear waste economy. The development and implementation of WP strategies will help Seattle's residents and businesses face the challenges of the changing recycling markets and issues around the proliferation of single-use plastics. It's also the most effective way for us to combat climate change within the materials management field.

#### **Part 7. Affordability Impact of Sub-Investment C**

As noted in Sub-Investment 3 – Part 3 above, most of the requested funds will be reinvested in Seattle's local communities through grant funding, promoting, or otherwise supporting

community-led solutions to WP. This will result in the creation of jobs, the growth of small businesses, and helping customers save money through activities such as buying less, reuse, repair, repurpose, and sharing resources in the community.

### **Part 8. Alternatives and Options to Consider for Sub-Investment C**

- **Proposed Investment above:** Support the continued investment in the WP Strategic Plan and Implementation Plan efforts as described above in detail, including hiring an FTE P&D, Spec II to support the WP Strategic Plan implementation beginning in 2026.
- **Alternative 1:** Hire a consultant rather than P&D, Spec II to help manage the WP implementation. This may be more expensive since we anticipate the P&D cost of \$179K in 2026 would be the equivalent of \$225K in consultant costs.
- **Status Quo:** Continuing the current path without investing in the WP Strategic Plan implementation would significantly impede SPU's ability to achieve the commitments in the Seattle Solid Waste Plan 2022 Update and devalue the community's input into the WP Strategic Plan. It could also hinder SPU's ability to move its WP goals forward; thus, generating more waste that needs to be managed downstream, all with a cost weather disposed of or diverted to recycling/composting.

## **SUB-INVESTMENT D: CONSTRUCTION & DEMOLITION (C&D) REUSE EVENTS AT TRANSFER STATIONS (GRANT DEPENDENT)**

### **Part 1. Summary of Sub-Investment D**

#### **Project Lead – SWPPM Staff**

Increasing reuse supports the City's Zero Waste vision, which entails moving upstream and looking at the whole life cycle of materials to eliminate waste and toxins, prevent pollution, reduce carbon emissions, and conserve natural resources. Seattle gets closer to zero waste by producing and using less. More details are provided in the City's 2022 Solid Waste Plan Update, Chapter 4: Waste Prevention & Reuse, which includes a recommendation to explore and expand market opportunities for reused material and repair services as this may help achieve a measurable drop in per-capita consumption and waste generation.

This investment focuses on operating reuse events for C&D waste at Seattle's transfer stations or other locations within Seattle. Between construction debris (62%) and furniture, appliances, and electronics (12%), approximately three quarters of the self-haul waste stream is likely recoverable if we provide consistent and reliable options for diverting reusable building material materials, reusable furniture, and quality broken furniture that can be repaired. SPU would work in collaboration with local partners to target the diversion of some of these materials/items.

### **Part 2. Targeted Commitments and Performance Measures for Sub-Investment D**

Major Milestones	Anticipated Outcomes	Timing
Restart or Expand Reuse Events at Transfer Stations or other sites in Seattle	<ul style="list-style-type: none"> <li>Hire consultant(s).</li> <li>Hold regular events (e.g., 2 events per month) at both transfer stations or other locations</li> <li>Anticipated events would result in ~500 lbs per event, or 2,000 lbs per month being diverted</li> </ul>	2025
Document and report on tons of materials diverted, broken out by category of material	<ul style="list-style-type: none"> <li>Annual Report documenting diverted materials</li> </ul>	2026-2030

### **Part 3. Financial Summary of Sub-Investment D**

Program Title	<b>C&amp;D Reuse Events at Transfer Stations (Grant-dependent) (\$000's)</b>						
Project Name	Various						
	2025	2026	2027	2028	2029	2030	TOTAL
Baseline - O&M	120	120	120	120	120	120	720
Baseline -Capital	N/A	N/A	N/A	N/A	N/A	N/A	N/A
<b>Total Baseline</b>	<b>120</b>	<b>120</b>	<b>120</b>	<b>120</b>	<b>120</b>	<b>120</b>	<b>720</b>

The plan for the C&D Reuse Events at Transfer Stations is to start prior to 2025 on a pilot basis using state grant funding. After proof of concept is established, the reuse events would be conducted on an on-going basis going forward from 2025, continuing to use grant funding as we are able to obtain it. The grant funding will pay for a contractor to host the events, remove reusable furniture as well as broken furniture, repair that broken furniture, and for another vendor to collect reusable building materials. These events will also likely provide additional salvaged lumber that can be redistributed through the Salvaged Lumber Warehouse (Investment described below).

### **Part 4. Capacity Plan to Deliver (Existing/Capital Only) Sub-Investment D**

An existing C&D P&D, Spec Sr., would take on the responsibility to hire the consultant(s), manage the consultant contract(s), and oversee the delivery of the C&D Reuse Events, working with existing transfer station staff is held at transfer stations.

### **Part 5. Racial Equity Impact of Sub-Investment D**

Collecting reusable building materials and broken/unbroken furniture for reuse at the Transfer Stations or other site in Seattle provides easy access for Seattle residents to drop-off of items at low cost, a reduction in potential illegal dumping of items and the impacts and costs associated with cleaning that up, and low cost and potentially free building products and furniture to Seattle residents. The manufacture of these materials and items targeted results in the harvest of raw materials, manufacture, transport, and distribution of these new products, each aspect

having an impact on climate. Captured usable wood and furniture can be repurposed or repaired, creating low-cost options for used furniture and other items for Seattle residents.

#### **Part 6. Climate and Sustainability Impact of Sub-Investment D**

As noted in Sub-Investment 4 – Part 5 above, the manufacture of products targeted by the C&D Reuse Events result in the harvest of raw materials, manufacture, transport, and distribution of these new products and materials, each aspect having an impact on climate. Captured usable wood and furniture can be repurposed or repaired, prolonging their life, keeping the materials in circulation, and decreasing their overall life cycle impacts on the climate.

#### **Part 7. Affordability Impact of Sub-Investment D**

As noted in Sub-Investment 4 – Part 5 above, collecting reusable building materials and broken/unbroken furniture for reuse at the Transfer Stations or other site in Seattle provides easy access for Seattle residents to drop-off of items at low cost, a reduction in potential illegal dumping of items and the impacts and costs associated with cleaning that up, and low cost and potentially free building products and furniture to Seattle residents.

#### **Part 8. Alternatives and Options to Consider for Sub-Investment D**

- **Proposed Investment above:** Provide ongoing funding for a contractor(s) to operate reuse events within the Seattle area. Benefits include the diversion of items, especially large format items, that could be repurposed for use that would otherwise end up in the landfill.
- **Status quo:** Reuse Events will not occur, resulting in items that could be targeted for reuse through this investment not being collected and diverted from disposal. This will result in the continued harvest of raw materials, manufacture, transport, and distribution of new products to take the place of the still usable wood and furniture that are being disposed of. It could also result in continued illegal dumping of items that otherwise might be captured for reuse, and a failure to create low-cost options for used furniture and other items for Seattle residents.

### **SUB-INVESTMENT E: C&D SALVAGE LUMBER WAREHOUSE SUPPORT (GRANT-DEPENDENT)**

#### **Part 1. Summary of Sub-Investment E**

##### **Project Lead – SWPPM Staff**

Increasing salvage and reuse supports the City's zero-waste vision, which entails moving upstream and looking at the whole life cycle of materials to eliminate waste and toxins, prevent pollution, reduce carbon emissions, and conserve natural resources. This Investment focuses on supporting the establishment and sustainable operation of a C&D Salvaged Lumber Warehouse in Seattle and hiring an associated long-term temporary staff person to support deconstruction projects. SPU would provide funding to local businesses to set up infrastructure to fill a key gap identified in the local circular economy for salvaged wood. The infrastructure we are aiming to establish is a secure, covered urban warehouse space large enough to initially accommodate at a minimum the wood recovered from 5% of Seattle's homes removed annually or about six tons per month. SPU would also hire a one long-term temporary SW P&D, Spec II to support the

monitoring of deconstruction projects for the 2025-2027 period, which are anticipated to increase over time with State and City incentives and/or mandates, to ensure the system is working as intended and projects are maximizing recovery of reusable materials. Once data is gathered and need is established, SPU may request to convert the temporary position to a permanent one.

SPU successfully applied for and was awarded \$4 Million in Federal grant funding. It is anticipated that other grant funding will become available that could also be tapped into for this project, especially if proof of concept and diversion data is established. Ultimately, the goal would be to spin off the Salvaged Lumber Warehouse to the private sector.

**Part 2. Targeted Commitments and Performance Measures for Sub-Investment E**

Major Milestones	Anticipated Outcomes	Timing
Staffing and Funding	<ul style="list-style-type: none"> <li>Hire a TES SW P&amp;D Spec II to support the Salvage Lumber Warehouse project</li> <li>Pursue and secure grant funding</li> </ul>	2025
Implement or continue to support Salvaged Lumber Warehouse	<ul style="list-style-type: none"> <li>Establish the Salvaged Lumber Warehouse project</li> <li>Process and reclaim 6 tons per month of salvaged lumber</li> <li>Develop Annual Report documenting results</li> </ul>	2025-2027

**Part 3. Financial Summary of Sub-Investment E**

Program Title	C&D Salvage Lumber Warehouse Support (Grant-dependent) (\$000's)						
Project Name	Various						
	2025	2026	2027	2028	2029	2030	TOTAL
Baseline O&M – Salvaged Lumber Warehouse	120	120	120	120	120	120	720
Baseline O&M – TES P&D, Spec II	161	167	174				502
Baseline – Capital	N/A	N/A	N/A	N/A	N/A	N/A	N/A
<b>Total Baseline</b>	<b>281</b>	<b>287</b>	<b>294</b>	<b>120</b>	<b>120</b>	<b>120</b>	<b>1,222</b>

The Investment for C&D Salvaged Lumber Warehouse Support, includes:

- **Salvaged Lumber Warehouse.** SPU is supporting the establishment of this warehouse in 2024 through the use of state grant funding. The support is estimated at \$10,000 per month following the first 1-1.5 years of more robust financial support. We will continue to seek grant support for this project out past any initial grant funding to continue its viability.
- **TES SW P&D, Spec II.** The Salvaged Lumber Warehouse will receive wood primarily from deconstruction projects. The TES SW P&D, Spec II will monitor and support increasing

deconstruction projects as well as track progress towards weight-based and climate emissions reduction goals associated with reclaiming lumber. At this time, we are only looking for funding from 2025-2027; however, once data is gathered and need is established, SPU may seek to convert the TES position to permanent one for 2028-on.

#### **Part 4. Capacity Plan to Deliver (Existing/Capital Only) Sub-Investment E**

The Deconstruction TES will have access to approximately \$50,000 annually of the C&D waste non-labor budget, which could be used for activities such as providing incentives, contracting for workforce training, or conducting outreach. Additional funding is anticipated to come from federal, state, and private sector funding opportunities.

#### **Part 5. Racial Equity Impact of Sub-Investment E**

Ensuring the successful operation of a Salvaged Lumber Warehouse locally, a pillar of the local wood circularity loop, goes together with increasing deconstruction and diverting C&D from the waste stream. Deconstruction has multiple benefits to communities across Seattle, including those that have experienced a lack of resources. By increasing deconstruction and salvaged lumber reuse in Seattle, we will have a positive impact on climate through greenhouse gas emission reductions, and on health and equity outcomes for vulnerable populations by improving air quality and creating training opportunities.

Construction workers are a vulnerable population in the workforce and are at risk of exposure to environmental and health hazards on the job. By increasing deconstruction over demolition, safer, healthier work sites for this workforce are created, as well as for residents and other community members near these projects.

In addition, deconstruction is more labor-intensive than demolition, and so not only is it safer for construction workers, but it also creates more jobs with relatively low barriers to entry. Furthermore, lower-income and marginalized communities and neighborhoods are often disproportionately impacted by the negative impacts of demolition because they do not always have the time or information necessary to advocate for themselves on this issue. By working to better incentivize deconstruction, SPU seeks to address this inequity by increasing healthy building removal practices in neighborhoods most impacted by poor air quality.

#### **Part 6. Climate and Sustainability Impact of Sub-Investment E**

As noted in Sub-Investment 5 – Part 5 above, increasing deconstruction and salvaged lumber reuse in Seattle will have a positive impact on climate through greenhouse gas emission reductions, and on health and equity outcomes for vulnerable populations by improving air quality and creating training opportunities. Incentivizing the deconstruction in Seattle of approximately 200 houses normally demolished annually will divert six tons of wood to reuse, achieving a potential net carbon benefit of approximately 7.6 metric tons of CO<sub>2</sub>eq per house compared to demolition. Every item salvaged and reused, prevents the harvesting of the equivalent raw materials, and impacts from manufacture, transportation, and distribution of the new product.

### **Part 7. Affordability Impact of Sub-Investment E**

As noted in Sub-Investment 5 – Part 5 above, deconstruction is more labor-intensive than demolition, and therefore, creates more jobs with relatively low barriers to entry. Also, SPU seeks to use incentives to make deconstruction less expensive and a more available alternative to demolition.

### **Part 8. Alternatives and Options to Consider for Sub-Investment E**

- **Proposed Investment above:** Support ongoing leasing costs for a Salvaged Lumber Warehouse and add 1.0 TES SW P&D, Spec II for deconstruction project monitoring and tracking for 2025-2027. Benefits include items described above in detail.
- **Status quo:** If this Investment is not funded, deconstruction and reuse businesses will continue to struggle to establish in Seattle due to high property values. SPU does not expect the private sector to establish this infrastructure without public support and seed funding. Deconstruction will continue to be hampered by the lack of a dedicated and sustainable Salvaged Lumber Warehouse located in or near Seattle. Without that processing and storage capacity, deconstruction will likely remain at current levels or decrease. Without incentivizing or requiring many more deconstruction projects, Seattle will continue to throw away or burn for energy approximately 6 tons of wood for each of the roughly 200 houses demolished annually and not achieve the potential net carbon benefit of approximately 7.6 metric tons of CO<sub>2</sub>eq per house compared to demolition. For all the materials targeted for reuse through this investment, we will continue to harvest raw materials, manufacture, transport, and distribute new products to take the place of the still usable lumber that we are disposing.



## 12. Customer Affordability Programs

<b>SBP Focus Area</b>	Empowering Our Customers, Community, and Employees
<b>SBP Goals</b>	Build trusted relationships, partnerships, and allyships with our customers and communities.
<b>SBP Strategy</b>	Provide utility assistance that makes a difference.
<b>Template Type</b>	Initiative
<b>SPU Branch/LOB</b>	PCC Branch/Customer Care Division
<b>Executive Sponsor</b>	Debra (Dee) Reed
<b>Project Manager/Lead</b>	Maryam Mason/Leslie Brinson
<b>Reporting Cadence</b>	Annual
<b>Funding</b>	
<b>Last Update</b>	September, 2023

### **Part 1. Summary of the Initiative**

SPU will continue to improve programs, procedures, and policies that help keep our services affordable for lower-income customers, help customers pay their bills on time, and prevent water shutoffs related to nonpayment.

Our utility bill assistance initiative focuses on providing:

- Discounted billing through the Utility Discount Program to help lower-income customers afford essential services in an ongoing way.
- Emergency financial assistance through SPU and Federal programs to help lower-income customer navigate episodic financial hardship.
- Customer focused payment flexibility through alternative bill payment options to help all customers who might need assistance to prevent service disruption.
- Reconnections to water service and a pause on shutoffs for nonpayment during extreme heat events

Our work to improve customer assistance includes implementing programs rooted in customer voice to improve customer experience and participation, and efforts to reach customers who may fall through cracks created by our traditional outreach. As such, SPU is partnering with Seattle City Light on a holistic evaluation of our utility bill assistance programs to inform future program improvements.

### **Part 2. 2025-2027 Commitments**

<b>Major Milestones</b>	<b>Qtly Timing</b>
Evaluation of utility bill assistance programs	Q2 2024
Implement utility bill assistance evaluation recommendations	2024-2026
Promise Pay payment plan implementation	2024

Preventing shutoffs during extreme heat	ongoing
---	---------

**Part 3. Racial Equity Impact**

SPU’s customer affordability programs are rooted in the fact that our region’s BIPOC community is disproportionately impacted by severe housing cost burden, and utility costs are a portion of that burden. While increasing the affordability of SPU services only addresses a fraction of housing costs, SPU affordability programs help thousands of customers prevent water service disruptions through discounts, financial assistance and payment flexibility.

**Part 4. Climate and Sustainability Impact**

This initiative does not have a climate or sustainability impact.

**Part 5. Affordability Impact**

This initiative is rooted in increasing the affordability of SPU’s services for our lower-income customers specifically, and more broadly, to help increase the ability of all customers to stay current on their bills and avoid shutoffs.

### 13. Side Sewer Assistance Program

<b>SBP Focus Area</b>	Empowering Our Customers, Community, and Employees
<b>SBP Goals</b>	Build trusted relationships, partnerships, and allyships with our customers and communities.
<b>SBP Strategy</b>	Provide utility assistance that makes a difference
<b>Type</b>	Investment
<b>SPU Branch/LOB</b>	DWW, Code Policy & Regulatory
<b>Executive Sponsor</b>	Ellen Stewart
<b>Project Manager/Lead</b>	Kevin Burrell
<b>Reporting Cadence</b>	Quarterly
<b>Funding</b>	Expanded on existing investment
<b>Last Update</b>	September, 2023

#### Part 1. Summary of the Investment

DWW Side Sewer Assistance Long-Range Planning								
2022	2023	2024	2025	2026	2027	2028	2029	2030
Phase I: Loans								
			Phase II: Maintenance Incentives					
					Phase III: Private Pipe Repair			

SPU’s pilot Side Sewer Assistance Program launched in 2022. Phase I provides 0% interest loans with no monthly payments due to low-income homeowners in need of urgent side sewer repairs. Phase II is in development and will offer incentives for side sewer preventative maintenance services such as inspection and cleaning. Poorly maintained side sewers increase costs and risks to both customers and SPU. SPU uses staff time and resources responding to hundreds of emergency calls from customers each year only to find that nearly nine out of 10 times the issue stems from a private side sewer.

This initiative will scale up the Side Sewer Assistance Program by adding one (1) to two (2) new program delivery models through Phase III (see table below for a comparison of Phases I – III). The new phase will focus on working towards improving system capacity issues through investment in lining or repairing leaky side sewers. By improving side sewers in targeted areas, SPU can greatly diminish the unwanted portion of inflow and infiltration from customer side sewers to its system. Potential areas of geographic focus for large-scale repair projects could include:

- Historically underserved and under-invested areas of the city.
- Sewer basins with wastewater capacity issues and limitations.
- Areas where private side sewers are proximal to sensitive receiving waters such as creeks and wetlands.
- Root hot spot areas.

- Right of way corridor projects with open road cuts where other projects are removing and replacing right of way surfaces.

Possible program delivery methods could include one or more of the following:

- Side sewer lining incentive/rebate/voucher (e.g., up to 50% of cost).
- Targeted basin or neighborhood scale repair or lining projects via on call contractors (performance-based contract).
- Combination of the above two, where capital investments are paired with on call contractors to coordinate repair of private side sewers at the lowest cost moment.

The expansion of the program into Phase III will require the addition of \$10.35M funds including three (3) FTEs to oversee the program’s research, development, and implementation: 1 FTE for Phase I and II, and 2 FTEs for Phase III. Currently, there is no FTE assigned to any of the phases. The currently funded TLE position will be replaced by the Phase I FTE. The contractor oversight required for Phases II and III would necessitate increases in SPU program and project management with a higher number of projects per year compared to Phase I.

<b>Side Sewer Assistance Phases</b>			
	I	II	III
<b>Delivery Model</b>	Loan	Maintenance Incentives	<i>Private Pipe Repair</i>
<b>Assistance Provided</b>	0% interest loans 10-year term	CCTV inspection Jetting / rodding	<i>CIPP, slip lining, or other</i>
<b>Phase's Goal</b>	Reduce financial burden of costly emergency side sewer repairs	Incentivize proactive side sewer care and maintenance	<i>Improve system capacity through I/I reduction</i>
<b>Assistance</b>	\$3,000 - \$45,000 per loan	\$500 - \$2000 per customer	<i>\$8000 per customer</i>
<b>Eligibility</b>	Households under 80% area median income	Households under 80% area median income	<i>Households within SPU-identified target areas</i> <ul style="list-style-type: none"> <li>• CSO basins</li> <li>• Root hot spots</li> <li>• Existing capacity issues</li> </ul>
<b>Annual Goals</b>	10-20 loans per year	100s incentives provided per year	<i>Est. 150-300 lining projects per year</i>
<b>Phase Administration</b>	Office of Housing Home Repair Program	Vendor to provide service w/SPU contract oversight	<i>Vendor to provide service w/SPU contract oversight</i>

<b>Timeline</b>	Implementation 2022	Development 2023 Implementation 2024	<i>Development 2025 Implementation 2027</i>
<b>SPU Staff</b>	Currently 1 TLE	1 FTE*	2 FTE*
<i>*This public-private partnership delivery model will require more SPU staff resources to oversee the service contracts</i>			

**Part 2. Targeted Commitments and Performance Measures**

<b>Major Milestones</b>	<b>Anticipated Outcomes</b>	<b>Qtly Timing</b>
Hire and onboard program team- 2 FTEs	Establish program team	Q2 2025
Draft program options analysis	Executive review of options	Q4 2025
Community engagement and feedback on program proposals (CBOs, CLs)	Preferred alternative(s) identified	Q1 2026
Engage consultant for program material development	Marketing and branding for program material	Q3 2026
Contractor/vendor selected	Program delivery method	Q4 2026
Full scale program implementation		Q1 2027

**Part 3. Financial Summary**

<b>Program Title</b>	<b>Side Sewer Assistance Phase III (\$000's)</b>						
<b>Project Name</b>	Private Pipe Lining						
	<b>2025</b>	<b>2026</b>	<b>2027</b>	<b>2028</b>	<b>2029</b>	<b>2030</b>	<b>TOTAL</b>
Baseline O&M (3 FTEs)	525	525	525	525	525	525	3,150
Baseline Capital			1,800	1,800	1,800	1,800	7,200
<b>Total Baseline</b>	<b>525</b>	<b>525</b>	<b>2,325</b>	<b>2,325</b>	<b>2,325</b>	<b>2,325</b>	<b>10,350</b>

**Part 4. Capacity Plan to Deliver (Existing/Capital Only)**

To implement the work at scale, SPU envisions utilizing consultant resources (with oversight and management from SPU staff). One or more 3<sup>rd</sup> party vendors would perform project tasks such as: customer outreach/coordination, project management, pipe lining/repair services, etc.

### **Part 5. Racial Equity Impact**

Low and fixed-income customers pay a disproportional amount of their income on their utility bills. The same is true when a broken side sewer needs to be repaired or wholly replaced, where costs can easily reach tens of thousands of dollars. As a result, few customers proactively clean or maintain their side sewers which compounds the overall financial burden for low- and fixed-income homeowners of owning and maintaining a side sewer in the long-term. Deferring maintenance leads to unnecessary backups into homes and expensive emergency repairs.

### **Part 6. Climate and Sustainability Impact**

Poorly maintained or broken side sewers are contributors to sewage backups and overflows, which result in sewage on streets, lawns, in homes, public places, or water bodies. These overflows present both a public health and environmental risk. With climate change, SPU also expects higher volumes and frequencies of storm events which can further strain system capacity.

This investment would work to reduce the number of leaky side sewers that can cause these environmental issues.

### **Part 7. Affordability Impact**

Poorly maintained or broken side sewers allow groundwater and stormwater to enter pipes. With an increase in the amount of wastewater flows to treatment plants there are increased costs, which gets passed along to ratepayers and customers. Private side sewers contribute a sizable percentage of SPU's systems' flows. SPU crews must respond to customer-reported side sewer backups and overflows, Wet weather conditions further strain system capacity. To expand that capacity, SPU undertakes costly capital projects such as the Ship Canal Project.

This investment would be a part of SPU's overall strategy to preserve the wastewater system's capacity for the future, and the reduction in costs.

### **Part 8. Alternatives and Options to Consider**

Phase I of the current program is focused on emergency issues that have already occurred and will be working to create incentives for side sewer maintenance with Phase II. This next wave of investments for Phase III will get out ahead of both issues being solved with Phase I and II for low-income customers. This program expansion will make side sewer assistance available to more customers. If no action occurs, customers will continue to not inspect, clean, or repair their side sewers which only continues the status quo.

This initiative is scalable, where more staff or funding could accelerate the scope of the assistance provided. Currently, Phase I is supported by a TLE. Through this expanded initiative, we propose to add three (3) FTEs to support all three phases of work.



## 14. Advanced Metering Infrastructure Planning

<b>SBP Focus Area</b>	Empowering Customers, Community, and Employees
<b>SBP Goals</b>	Build trusted relationships, partnerships, and allyships with our customers and communities.
<b>SBP Strategy</b>	Empower and support customers to make sustainable behavioral changes.
<b>Type</b>	Investment
<b>SPU Branch/LOB</b>	PCC and Water LOB
<b>Executive Sponsor</b>	Idris Beauregard, Alex Chen
<b>Project Manager/Lead</b>	Natasha Papsoueva
<b>Reporting Cadence</b>	Quarterly (for investments)
<b>Funding</b>	Add
<b>Last Update</b>	December, 2023

### Part 1. Summary of the Investment

SPU is currently in pre-planning evaluation stage of an Advanced Metering Infrastructure (AMI) project that would replace the majority of SPU’s mechanical metering assets with electronic meters, equipped to transmit real time water consumption data, establish a backhaul network to transmit consumption data into a cloud base meter data management solution, enable automated remote meter reading and monthly billing, and provide accurate water consumption information to customers through SPU’s Utility Services Customer Portal (Figure 1).

**Figure 1. Water AMI.**

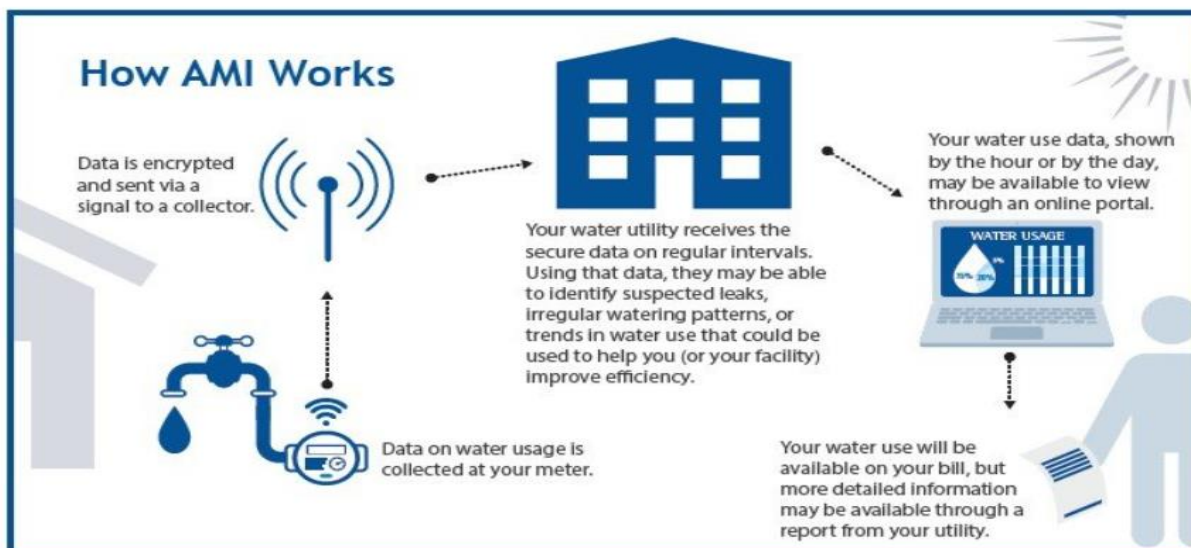

Environmental Protection Agency. (n.d.). EPA. <https://www.epa.gov/watersense/advanced-metering-infrastructure>



This investment proposal covers the planning stages of AMI Project. The project represents a transformational opportunity for SPU to modernize its metering operations and management of meter assets. Currently, over 76% of SPU’s meters are at or over 20 years old (Figure 2). SPU does not have a regular meter testing and replacement schedule. Rather, meters are replaced upon failure.

**Figure 2. SPU Meters by size and age as of May 2023.**

Meter Size (in)	Age (years)						TOTAL
	0-4	5-9	10-15	15-20	20-25	>25	
3/4	7,539	7,965	7,434	12,458	12,430	116,591	164,417
1	1,658	1,240	1,015	2,054	2,523	15,263	23,753
1.5	424	387	321	496	684	3,090	5,402
2	546	553	442	554	727	3,027	5,849
3	27	95	80	91	77	123	493
4	317	305	187	108	149	362	1,428
6	115	90	30	52	95	250	632
8	41	41	8	14	43	153	300
10	14	11	1	4	19	13	62
12	6	3	-	3	13	3	28
16	-	-	1	1	-	-	2
20	-	2	-	-	1	-	3
24	-	-	-	-	1	-	1
<b>TOTAL:</b>	10,687	10,692	9,519	15,835	16,762	138,875	<b>202,370</b>

Replacement of ageing mechanical meters with AMI enabled electronic meters would improve accuracy of registered water consumption, water leak detection, reduce consumption estimates, improve billing timeliness and accuracy, reduce claims, and enhance overall customer experience. Other benefits of implementing AMI for SPU include:

- Improved meter asset management based on actual meter performance data.
- Direct customer engagement in water consumption, conservation, and customer benefit programs.
- Improved system planning and capital investments delivery.
- Staff safety and reduction in work-related injuries.
- Environmental sustainability with reduction of field visits.
- Climate change resiliency, as AMI allows real time consumption monitoring and management.
- Building capacity for future innovation with Smart Water devices and IoT integration.

**Part 2. Targeted Commitments and Performance Measures**

AMI implementation would require a significant amount of planning and preparation and would involve collaboration with multiple stakeholders and city departments.

Major Milestones	Anticipated Outcomes	Timing
AMI Business Case	Full scale business case for AMI implementation with accompanying options evaluation, financial analysis, and recommendations	Q1 through Q4 2025 – Business Case development and completion
AMI resource planning, RFP development	Development of RFP with functional requirements and evaluation criteria for AMI solutions and implementation, IT integration, implementation schedule and network design.  Development of preliminary AMI implementation plan defining preferred procurement and installation approaches and recourse estimates.	Q1 2026 through Q1 2027  Q1 2027
Customer and Stakeholder engagement effort	Develop customer and stakeholder engagement effort around AMI implementation, initiate customer and stakeholder outreach before AMI project kick off.	Q1 2027
RFP Solicitation and Contract Award	RFP for AMI implementation published before summer 2028 SBP rate path adoption.  Vendor contract awarded.	Q3 2027  Q2 2028
Project Initiation	AMI Project initiated	Q2/Q3 2028 Project kick off. Project conclusion would depend on implementation schedule chosen.

### **Part 3. Financial Summary**

Financial investment needed for AMI implementation directly depends on the type of AMI system SPU chooses to implement. SPU reviewed multiple factors that impact an AMI implementation program. A list of key variables and the options within each are described below:

**Technology type:** Several options are available, including standard and high-powered fixed network radio frequency systems with infrastructure owned by the City, cellular-based systems that utilize existing cellular network infrastructure, and managed Network-as-a-Service (NaaS) systems under which the AMI vendor maintains ownership of network infrastructure.

**Meter replacement:** The proportion of meters in the system that are replaced during AMI deployment. A typical AMI installation, particularly for older utilities, involves full replacement of all water meters. However, in some instances, meters that have been installed for short periods of time may be able to be retained and simply retrofitted with AMI functionality, versus being fully replaced.

**Deployment timeline:** Length of time for full deployment of the AMI program is driven by system size, budgetary and staff constraints, and size of deployment workforce.

SPU intends to conduct a competitive RFP process that will identify the AMI system and project options.

For 2025-2027 SBP period, SPU will focus on development of the business case, project resource planning, communication and outreach effort and RFP development. The planning phase costs are estimated to be approximately **\$750K**, with business case development being at **\$250K**; Project management and resourcing plan at **\$50K**; RFP development and contracting negotiations support - **\$200K**; Communications and Outreach to the community and stakeholders before we start implementation - **\$250K**. This is O&M planning funding through 2027.

The majority of the project costs are capital investment funding. The projected rate impact of AMI investment over 6 years is 0.2%, which will be reevaluated based on the results of the business case analysis.

Program Title	Advanced Metering Infrastructure (AMI) Investment (\$000's)						
Project Name	AMI Project						
	2028	2029	2030	2031	2032	2033	TOTAL
Baseline Capital	7,445	18,613	32,758	37,225	34,470	18,613	<b>149.900</b>

SPU anticipates seeing cost savings related to staff reductions, vehicle inventory, meter reading equipment, reduced water leak adjustments, and meter replacement costs. Meters Reading operational cost savings are estimated at \$1.4M annually, Customer Service operational costs - at \$358K annually, reduced Leak Adjustments are expected to yield savings at \$2.5M annually, and meter replacement mitigation is anticipated to result in \$433K annual savings.

The AMI investment is being planned under the following key assumptions:

- SPU will focus on minimizing workforce impacts from AMI by retraining staff and transitioning them to different roles.
- Customers will be offered an optout option from AMI implementation.
- SPU will be able to leverage existing technology assets in its portfolio, such as its Utilities Customer Self-Service Portal, CCB billing system, and MSCS meter data management system.
- Some meters older than 5 years may be able to be retrofitted, but it is unknown at this stage of analysis.
- SPU anticipates additional revenue recovery due to the introduction of more accurate electronic meters; however, the exact extent of the recovery cannot be firmly projected at this point.

#### **Part 4. Capacity Plan to Deliver (Existing/Capital Only)**

The project would utilize existing employees from multiple SPU branches and LOBs including Water LOB, DWW LOB, PDEB, Financial and Risk services branch, PCC branch, as well as other City departments subject matter experts and stakeholders. Existing staff may be supplemented with project-related temporary recruitment on as needed basis. Business case, resource planning and RFP development would require consultant engagements. Once the vendor is identified, the project team would consist of both City, vendor, and consultant staff.

#### **Part 5. Racial Equity Impact**

AMI implementation offers tangible improvements in utility service delivery and affordability for low income and underserved communities and customers. With a strong intersectionality between race and income distribution, old metering infrastructure and occurrence of water leaks are often very prevalent in low income and BIPOC communities, disproportionately affecting disadvantaged populations. AMI implementation would bring direct visibility to real time water usage and empower customers to manage their own consumption, improve leak detection and increase affordability of utility services through monthly billing.

#### **Part 6. Climate and Sustainability Impact**

Advanced Metering Infrastructure provides foundational capabilities in utility operations and customer engagement that will allow SPU to successfully mitigate climate change impacts and provide sustainable utility services. AMI's capability to capture water consumption real time provides customers with direct visibility to their water consumption trends, giving them opportunity to actively manage how they use water. This essentially changes the relationship between the utility and customers, making the latter active co-managers of our water resources, particularly during water advisory periods. Seeing direct impacts of changes in how they use water, customers will be more engaged in water conservation and other climate resiliency programs.

Improved water consumption and asset performance data obtained through AMI capabilities will transform the utilities asset management practices fully enabling predictive maintenance and asset condition monitoring. This will in turn result in improvements in operations and maintenance of the utility infrastructure as well as capital improvement projects planning.

Additionally, immediate climate resilience impacts will include reduction in vehicle utilization and emissions, as the utility will see significant reduction in manual meter reading operations.

### **Part 7. Affordability Impact**

With AMI implementation, SPU will have an opportunity to offer monthly bills to its customers. Currently, the utility bills residential customers on a bi-monthly basis, with an average utility bill at \$323.00. Switching to monthly billing will generate a more affordable monthly bill amount. Customers will also have visibility to bills and real time water consumption on the Utility Customer Self Service Portal. This will allow customers to see how participation in water conservation and other utility programs impact their SPU bills and understand how they use water.

AMI implementation will also significantly reduce water leaks and will enable the utility to promptly issue abnormal consumption notifications, thus reducing leak related high utility bills.

### **Part 8. Alternatives and Options to Consider**

AMI implementation does not have alternatives that would achieve similar outcomes. The utility can pursue options in deciding how it would implement AMI programs from the perspective of technical solutions, project schedule and phases of work. These options would be evaluated in the business case analysis to identify the preferred path for SPU. Alternatively, SPU can choose to delay AMI implementation. The utility, however, would still be incurring the costs associated with meter replacement due to the age profile of its current meters. Aging meters would continue losing accuracy with the registered consumption increasing over the years. SPU would be facing increasing costs in its technology portfolio without realizing the benefits of updated cloud-based solutions, since the billing and metering systems are shared between SPU and SCL. From the strategic perspective, the utility would lose the opportunity to modernize its operations, bring customer experience in line with what is currently provided by most water utilities in the region, and build capacity for climate change resilience.

## 15. Seeds of Resilience Impact Investment Fund

<b>SBP Focus Area</b>	Empowering Customers, Community, and Employees
<b>SBP Goals</b>	Build trusted relationships, partnerships, and allyships with our customers and communities. Be an anchor institution that advances equity, addresses environmental justice, and partners to leverage holistic community benefits in all that we do.
<b>SBP Strategy</b>	Lead with race and social justice in delivering equitable engagement, capacity building, investment outcomes, and opportunities.
<b>Template Type</b>	Initiative
<b>SPU Branch/LOB</b>	GM's Office
<b>Executive Sponsor</b>	Andrew Lee
<b>Project Manager/Lead</b>	Kahreen Tebeau
<b>Reporting Cadence</b>	Annually
<b>Funding</b>	\$600,000 in annual ongoing funding from utility rate payer dollars
<b>Last Update</b>	September, 2023

### **Part 1. Summary of the Initiative**

“Seeds of Resilience” is SPU’s impact investment fund/program that aims to advance equity and environmentally sustainable waste and water management activities in private sector markets that have a business nexus with SPU.

The program operates by identifying a business need for SPU, such as more service providers who can clean restaurant grease traps at an affordable price (which benefits our DWW line of business), or more workers trained with deconstruction skills (which benefits our SW line of business). We then reach out to partners in the private sector who can help us generate these outcomes, center equity in the design of the project, use a variety of contracting and procurement vehicles, and measure outcomes.

It requires building relationships with organizations we have not previously engaged before and fundamentally changing how we partner with the private sector to achieve our vision of One Water, Zero Waste, and being Community Centered.

### **Part 2. 2025-2027 Commitments**

<b>Major Milestones</b>	<b>Qtly Timing</b>
Identify and invest in existing and new projects (up to annual budget)	4Q 2024, 2025, 2026
Report out on evaluation outcomes for projects concluded in 2024, 2025, and 2026.	On-going

### **Part 3. Racial Equity Impact**

The Seeds of Resilience actively centers social and racial equity in the design of projects that are funded through this program. That means that for each project we fund, we are advancing economic opportunities or environmental justice for frontline community members. For example, we are currently funding stipends for formerly incarcerated community members to attend a three week workforce development training to help them develop deconstruction skills, which will enable them to better compete for gainful employment in both the construction and deconstruction fields.

### **Part 4. Climate and Sustainability Impact**

Every project funded by the Seeds of Resilience has a positive impact on environmental sustainability. This is a requirement of the program, in terms of project criteria that must be met for every funded project. This often has a positive impact on climate mitigation or adaptation, though not climate is not the only environmental benefit we value with our projects. For example, with the Fats, Oils, and Grease (FOG) Community Jobs Program, we trained and equipped BIPOC and other frontline community members to become small businesses that could clean out restaurants' grease traps. This helps the environment by keeping FOG out of the drainage and wastewater system. And disposing of FOG properly also helps prevent greenhouse gas emissions. In this way, this project advanced both climate mitigation and broader environmental sustainability tied to our wastewater system.

### **Part 5. Affordability Impact**

Every project funded by the Seeds of Resilience must have a business nexus and business case for SPU. This means that it helps SPU reach its stated goals, mission, and vision, of better managing waste and water. Often the private sector can perform work more efficiently and nimbly than government agencies. The Seeds of Resilience program aims to partner with private sector contractors and organizations to perform valued work that SPU does not or cannot take on as a government entity. For example, the FOG Community Jobs Program is aimed at helping local restaurants (who are our commercial business customers) better comply with FOG requirements by training and equipping small businesses who can offer this service more affordably than large national plumbing corporations. This in turn helps SPU keep its wastewater system free of FOG and can help prevent CSOs, which is a costly regulation for SPU.

### **Part 6. Alternatives and Options To Consider**

Incorporating non-utility sources of funding into our impact investment fund, which is currently limited to utility dollars only, would allow us to pursue projects that have value for our community but may go beyond the scope of pure SPU utility business nexus. It would allow us to have a broader, more wholistic impact and engagement in the projects we are funding.

We may also consider partnering with other City departments on joint-impact projects where appropriate.



## 16. Equity in Contracting

<b>SBP Focus Area</b>	Empowering Customers, Community, and Employees
<b>SBP Goals</b>	Build trusted relationships, partnerships, and allyships with our customers and communities.
<b>SBP Strategy</b>	Lead with race and social justice; engage WMBE firms; and develop and implement strategies and solutions that eliminate barriers to entry and inequitable access to contracting opportunities.
<b>Template Type</b>	Initiative
<b>SPU Branch/LOB</b>	Financial and Risk Services Branch
<b>Executive Sponsor</b>	Paula Laschober
<b>Project Manager/Lead</b>	Jana Duran
<b>Reporting Cadence</b>	Annually for SBP
<b>Funding</b>	O&M
<b>Last Update</b>	09/05/2023

### Part 1. Summary of the Initiative

**Equity in Contracting** is an initiative focused on

1. Engaging WMBE firms, to gain greater knowledge and understanding of the barriers to entry and inequitable access to city contracting opportunities, and
2. Developing and implementing actionable strategies and solutions to improve access to opportunities for WMBE firms and enhance the overall experience of doing business with the City.

2022 Accomplishments:

- Applied racial equity toolkit to the communication of consultant contracting opportunities.
- Drafted a racial equity toolkit summary memorandum, initiating the Equity in Contracting Program.
- Formed the Equity in Contracting cohort, that includes 2 sponsors and 14 staff, and encompasses 3 departments and each of the SPU branches / Lines of Businesses.
- Held informal interviews with 15 WMBE firms to gather information about their experiences doing business with the City of Seattle and business needs.

2023 Accomplishments:

- Developed strategies and tactics for 2 improvement opportunity pathways:
  - mapping connections and resources, and
  - communicating contracting opportunities to WMBE firms.
- Hired a black- and woman-owned consulting firm to provide culturally inclusive research and analytics by engaging directly with the WMBE community, to better understand their needs and barriers to opportunity, and to gather their ideas.

- Developed and administered WMBE Experience Survey, to include focus groups and one-on-one interviews, including compensation for interview participants’ time and effort.
- Established WMBE Experience Survey core team and key connectors workgroups.
- Began producing an actionable strategies and solutions report, from WMBE Experience Survey data and focus group and one-on-one interviews.
- Began exploring city-wide accessible community business organization and community organization roster/contracting options.

2024 Plan:

- Develop WMBE Experience Survey response plan. (TBD)
- Implement response plan strategies and solutions. (TBD)
- Report response plan progress and recognize accomplishments. (TBD)

**Part 2. 2025-2027 Commitments**

Major Milestones	Qtly Timing
Implement WMBE Experience Survey response plan strategies and solutions.	TBD
Report response plan progress and recognize accomplishments.	TBD
Develop and Administer WMBE Experience Survey #2	2Q 2026

**Part 3. Racial Equity Impact**

Eliminate barriers to entry and inequitable access to contracting opportunities for WMBE firms, with intention to:

- Increase the volume of consultant contracting proposals submitted by WMBE firms as Primes.
- Increase consultant contracts awarded to WMBE firms as Primes.
- An increase in WMBE firm subconsultant participation on consultant contracts.
- An increase in blanket contracting proposals submitted by WMBE firms.
- An increase in blanket contracts awarded to WMBE firms.
- An increase in WMBE firm subcontracting participation on blanket contracts.

Additional Statistics:

- 17% of consultant contracting proposals received by SPU in 2022 were submitted by WMBE firms.
- Total city-wide purchasing spend in 2022 = \$433M
- Total SPU purchasing spend in 2022 = \$57M (~13% of city-wide goods and non-professional service spend)
- Total city-wide consultant contracting spend in 2022 = \$215M
- Total SPU consultant contracting spend in 2022 = \$35M (~16% of city-wide consultant contracting spend)

#### **Part 4. Climate and Sustainability Impact**

If successful, this initiative will direct a greater portion of City procurement dollars to local WMBE firms. Because the owners and employees of these firms work and live in and around the City of Seattle, they are likely to make a greater effort in caring for the environment and actively engaging in sustainability efforts.

#### **Part 5. Affordability Impact**

This initiative aligns with the City’s BIPOC Generational Wealth Building, progressive procurement program, encompassing strategies that bring together local governments and place-based “anchor institutions” to recirculate wealth in their communities through intentionally equitable and regenerative procurement practices that re-localize economic activity, build local multipliers, and end leakage and financial extraction. These strategies harness the immense spending power of governments and anchor institutions to keep a progressively larger proportion of the amount that these institutions spend in the local economy. Procurement is specifically channeled towards firms and institutions that shift power to individuals and families largely excluded from it in the dominant economy including worker owned cooperatives and social enterprises.

City-wide commitment: Direct at least 10% from the City’s multi-billion-dollar annual procurement expenditures towards BIPOC worker-owned enterprises by 2025 and 25% by 2030.

## 17. Employee Life Cycle Initiatives

<b>SBP Focus Area</b>	Empowering Our Customers, Community, and Employees
<b>SBP Goals</b>	Invest in all of our employees
<b>SBP Strategy</b>	Foster a more equitable workplace, work culture, and better work opportunities.
<b>Template Type</b>	Initiative
<b>SPU Branch/LOB</b>	People, Culture and Community
<b>Executive Sponsor</b>	Idris Beauregard
<b>Project Manager/Lead</b>	Adreinne Thompson
<b>Reporting Cadence</b>	Annual
<b>Funding</b>	O&M - \$2.4M from DWW, SW
<b>Last Update</b>	November, 2023

### **Part 1. Summary of the Initiative**

In order to create a workplace culture that promotes equity and inclusion SPU is examining the Employee Life Cycle beginning when an employee first applies, through their departure at SPU. Initiatives and policy development include the employee onboarding experience, workforce development, succession planning and the offboarding experience. The initiatives builds on the successes SPU has had in creating a diverse workforce and creating professional growth opportunities through training, mentorship and career advancement.

The funding is dedicated to hiring new staff during the 5-year SBP for total funding of \$2.4 million and will be funded by Water, Drainage and Wastewater, and Solid Waste funds.

### **Part 2. 2025-2027 Commitments**

<b>Major Milestones</b>	<b>Qtly Timing</b>
Evaluation period to assess the employee lifecycle touchpoints	2Q 2025
Generate recommendations to develop or modify processes and policies	4Q 2025
Hire appropriate staffing to take on new employee support initiatives	2025 – 2030

### **Part 3. Racial Equity Impact**

Creating an environment that promotes equity and inclusion provides employees a feel of belonging and satisfaction in their job. This will also help employees deliver quality service to the public and have an employee workforce that is representative of the community in all positions within SPU..

### **Part 4. Climate and Sustainability Impact**

Employee workforce initiatives will improve employee retention and help preserve institutional knowledge to ensure efficient and sustainable utility operations.

**Part 5. Affordability Impact**

Employee workforce initiatives will improve employee training and skills development, and improve employee job satisfaction and retention. Employees will be further engaged in and recognized for identifying and implementing operational improvements. This will improve utility efficiency and reduce costs, helping to keep rates affordable.

## 18. Alternative Funding and Financing

<b>SBP Focus Area</b>	Strengthening Our Utility’s Business Practices
<b>SBP Goals</b>	Enhance ratepayer affordability and utility accountability
<b>SBP Strategy</b>	Deliver on high impact affordability and accountability commitments
<b>Template Type</b>	Initiative
<b>SPU Branch/LOB</b>	All
<b>Executive Sponsor</b>	Andrew Lee, Paula Laschober
<b>Project Manager/Lead</b>	Danielle Purnell
<b>Reporting Cadence</b>	Annual
<b>Funding</b>	Base budget
<b>Last Update</b>	September 2023

### **Part 1. Summary of the Initiative**

This initiative is a cornerstone of SPU’s efforts to keep rates affordable through pursuit of alternative funding and financing sources and strategic partnerships with agencies and other types of funders. SPU’s approach to alternative funding and financing pursuits is based on a ‘best fit’ approach, where SPU matches its funding priorities with available funding sources that will yield a solid return on investment, which SPU defines broadly to include community needs and priorities, as well as financial return. SPU will also pursue opportunities to leverage coordination and partnerships with other City departments and agencies, as well as community and corporate partners. Through this initiative, SPU will continue to develop and refine structures and strategies to ensure that this work is robust, impactful, and efficient. Structural improvements include developing an inventory and rating of funding sources, tracking performance, and setting performance targets, as well as streamlining internal processes and procedures for pursuing funding opportunities and ensuring compliance with funding requirements. Strategic improvements include developing a multi-year funding portfolio strategy (matching SPU needs to sources), pursuing a funding advocacy strategy, and relationship-building with key funders and public, community, private, and philanthropic partners.

### **Part 2. 2025-2027 Commitments**

<b>Major Milestones</b>	<b>Qtly Timing</b>
Establish, publish, and maintain an inventory of external funding, financing, and partnership sources.	Annually
Establish, publish, and maintain an SPU inventory of candidate projects for alternative funding and financing.	Annually
In coordination with all lines of business, establish and adjust rubrics for assessing funding opportunities and revenue partnerships, including	Annually

assessing return on investment of awarded grants, loans, and other sources.	
Develop, update, and implement an annual funding advocacy strategy for local, state, and federal opportunities that includes funding levels and policies.	Annually
Clarify and streamline internal processes and procedures for grant and alternative funding phases, from pursuit to award to implementation and close out.	Annually
Develop and maintain key relationships with funders and funding partners.	Annually

**Part 3. Racial Equity Impact**

By securing additional revenue (i.e., through grant funding) or lowering borrowing costs (i.e., through loan financing), alternative funding sources help keep SPU rates more affordable. Utility bills have a disproportionate burden on households with lower incomes, since a greater percentage of a household’s income goes to pay for core needs, such as utilities. Consistent with demographics throughout the city, customers who have lower incomes also tend to be more racially diverse. This reinforces the importance of securing alternative funding and financing and the benefits it contributes toward affordability.

Moreover, pursuing and securing alternative funding and financing can also lead to more equitable outcomes and quality of life improvements in communities that have been historically underinvested. Depending on the funding source, these additional funding opportunities create pathways for SPU to carry out programs or projects that address community needs and achieve community benefits greater than what utility ratepayer funds can accomplish.

**Part 4. Climate and Sustainability Impact**

This initiative enables SPU to accomplish more on its climate and sustainability priorities, especially related to habitat restoration, infrastructure, and other environmental work. This is particularly timely, as new funding opportunities focused on climate adaptation and mitigation and climate justice have opened up through federal and state level action, including the federal Bipartisan Infrastructure Law (BIL), the federal Inflation Reduction Act (IRA), and the state’s Climate Commitment Act (CCA).

**Part 5. Affordability Impact**

A primary outcome of this initiative is to help keep SPU rates affordable by leveraging and/or supplementing ratepayer funds or reducing borrowing costs to carry out programs and make capital investments. Utilizing external funds, such as from state, federal, or philanthropic sources, helps each ratepayer dollar accomplish more to meet SPU and community needs and priorities.





## 19. Drainage and Wastewater Asset Management Program

<b>SBP Focus Area</b>	Strengthening Our Utility’s Business Practices
<b>SBP Goals</b>	Manage assets and risks optimally
<b>SBP Strategy</b>	Address aging, undersized, and at-risk facilities and infrastructure to ensure continuous service delivery
<b>Type</b>	Investment
<b>SPU Branch/LOB</b>	DWW LOB
<b>Executive Sponsor</b>	Ellen Stewart
<b>Project Manager/Lead</b>	Tara Wong Esteban
<b>Reporting Cadence</b>	Quarterly
<b>Funding</b>	New O&M & CIP add
<b>Last Update</b>	September, 2023

### **Part 1. Summary of the Investment**

A significant amount of SPU’s sewer pipes need to be replaced or rehabilitated due to age. SPU is investing in pipe lining to extend the life of aging pipe infrastructure. Replacing pipes can be up to 10 times more expensive than repair or rehabilitation. Pipe relining (a type of rehabilitation) is a more affordable and sustainable approach to reducing system risks and improving resiliency. SPU will develop an in-house pipe lining team as another cost-effective option to respond to urgent needs.

There are three areas of opportunities to implement an in-house full-pipe lining program:

1. *SPU is investing heavily in pipe lining as a cost-effective measure to repair aging sewer pipes. Creating an in-house full pipe lining program is in line with SPU’s vision.*

Similar to many mature and large US Utilities, a significant amount of SPU’s sewer pipes needs either replacement or rehabilitation due to the age and condition of the pipe infrastructures. Excavating and replacing pipes, in a significant amount, is not practical nor desirable due to cost and impact on communities. Based on available data, replacing pipes can be up to 10 times more costly than repair/rehabilitation. Therefore, repairing/rehabilitating pipes to extend the useful life of the aging pipes when possible is preferred because it is more sustainable and cost-effective. Pipe lining is one of the most cost-effective methods to rehabilitate the aging sewer system, therefore, SPU has been and will continue to invest heavily in pipe lining for the foreseeable future.

2. *Some high-risk pipes may fail before contracted full-pipe lining work can be fully executed. The in-house program can address these high-risk pipes before they become emergency projects.*

Currently, the Sewer Rehabilitation Program follows an established process to evaluate pipe conditions and determine applicable pipe rehabilitation methods. The rehabilitation

program relies on contracted Public Works when full-pipe lining is recommended. The rigorous and complex design process and Public Works contracting process currently takes between three to four years from design through the construction stage. However, there are some pipes where the predicted window to rehabilitate these pipes may be much shorter than the contracted work timeline.

Delaying the repair of these pipes may lead to emergency failures which are costly, disruptive to our customers and the community, and disruptive to SPU's planned work. This would mean SPU could experience increased pipe emergencies and remain in a largely reactive mode. The reactive mode is contrary to SPU's vision of managing the system effectively and proactively. Developing a SPU MH to MH full-pipe lining program would allow SPU to have a mechanism for responding to urgent needs in a cost-effective manner. It will improve our customer experience.

- 3. The in-house full pipe lining program, coupled with the existing in-house spot lining program, will further reduce the system risks, and create a more resilient SPU.*

Following the 2018-2023 SPU SPB plan, SPU has implemented a successful in-house spot lining program that is proven to be an efficient and cost-effective approach to address certain sewer system problems, to support meeting SPU's regulatory requirements and reduce the likelihood of structural failures of the system. The In-house Full-Pipe lining Program will supplement the spot lining program and help SPU further reduce the system risks and improve resiliency.

However, before we can focus on building a new in-house full-pipe lining program, we first need to catch up on routine maintenance and assess the condition of our existing assets – focusing on our neglected drainage assets. SPU is actively advancing SBP effort #18B – Expansion of Drainage Rehabilitation Work. We've completed our Drainage Program Review, hired a drainage rehabilitation program manager, added a new pipe assessor to focus on drainage assets and have started completing some simple drainage rehabilitation projects.

Initially, we want to hire ½ of the identified full-pipe lining crew to focus on CCTV of existing drainage assets. By doing this upfront condition assessment work, we can use the condition information to prioritize drainage rehabilitation projects. We will spend the first five years completing this assessment work until the remaining FTEs are hired to begin training for the full-pipe lining program. In 2030, we will also need to add a Planner based on lessons learned from our in-house spot lining program. The planner is needed to ensure the operations side runs smoothly including ordering materials.

Finally, we are asking to add one Senior Construction Maintenance Equipment Operator who is needed to maintain the new decant facility that will be constructed at South Operations Center (SOC). We will also need to purchase a new loader to maintain the decant facility. The new decant facility is scheduled to be completed in 2026.

Once the full team is hired and trained in 2030, it is expected that this crew can line between 75-110 sites annually at a cost of \$36,000 to \$53,000 per mainline. In comparison, a typical non-emergency public works contracted job would cost about \$65,000 per mainline, and urgent job-order contract work would cost about \$250,000 per mainline.

**Part 2. Targeted Commitments and Performance Measures**

Major Milestones	Anticipated Outcomes	Timing
Hire first 8 FTEs	CCTV drainage assets for condition assessment	2025-2029
Hire Operator	To maintain SOC decant facility	2026
Plan and procurement for full-pipe lining crew	Thorough plan to train and onboard new staff in addition to equipment procurement	2026-2029
Hire remainder of FTEs	Fully staffed lining crew – day shift and swing shift	2030

**Part 3. Financial Summary**

Program Title	DWW Frontline Resources (\$000's)						
Project Name	DWW and Water “One Water” North Operations Complex						
	2025	2026	2027	2028	2029	2030	TOTAL
Baseline O&M	1,169	1,282	1,282	1,282	1,282	340	6,637
Baseline Capital	3,280	220	0	0	0	3,683	7,483
<b>Total Baseline</b>	<b>4,749</b>	<b>1,502</b>	<b>1,282</b>	<b>1,282</b>	<b>1,282</b>	<b>4,023</b>	<b>14,120</b>

2025: hire crew chief, 4 leads, 4 collection workers – focus on drainage assets (CCTV)

2026: hire 1 equipment operator for SOC decant facility

2030: hire 1 lead, 6 collection workers (2 of the 6 collection workers will be floaters to ensure fully staffed crews), 1 planner

Starting in 2030, the lining crew will charge approximately 70% of their time to CMOM CIP work and 30% will be O&M overhead

Includes annual fuel and maintenance cost for fleet. Small fleet is leased.

**Part 4. Capacity Plan to Deliver (Existing/Capital Only)**

The first 5 years will focus on core O&M work to advance a drainage rehabilitation program.

Once the full team is hired and trained in 2030, it is expected that this crew can line between 75-110 sites annually at a cost of \$36,000 to \$53,000 per mainline. In comparison, a typical

non-emergency public works contracted job would cost about \$65,000 per mainline and urgent job-order contract work would cost about \$250,000 per mainline.

At this early planning stage, it is assumed that the Program will:

1. Utilize UV technology to line high risk sewer pipe up to 12" diameter with possibility to expand to larger pipe in the future.
2. Include up to additional sixteen field staff and one planning and scheduling staff dedicated to the program. See Department Workforce Impacts section below.
3. Incur, on average, approximately \$4 million per year based on the high-level budget analysis. The request to expand the lining program was included in the SPU 2021-2026 SPU Strategic Business Plan and costs are available in the Pipe Rehabilitation Program capital project placeholder and Lining Crew placeholder in the adopted/endorsed budget for 2024-2027 specifically for lining rehab projects (shifting contracted spending to in-house crew spending).
4. Require three to five years to plan and implement after the investment is approved.
5. Allow 1.5-3 days to complete each site.

#### **Part 5. Racial Equity Impact**

The majority of our frontline staff are people of color, so developing this in-house program offers them an opportunity to grow their skills, keeps work in-house, creates a more resilient operation and helps improve employee morale.

#### **Part 6. Climate and Sustainability Impact**

Investing in an in-house lining crew will increase our ability to rehabilitate and extend the life of our aging infrastructure. This work will help us keep sewage within our pipes and help reduce contamination of our groundwater, water bodies or damage to private property.

#### **Part 7. Affordability Impact**

This investment does not have significant impact to our rates. Once the full-pipe lining team is running and trained, they will be focused on CIP projects that have already been included in our long-term capital budget. Adding the in-house crews offers SPU more flexibility for construction options and provides us with another way to complete urgent repairs. Overall, completing lining projects in-house is more cost effective than hiring a contractor to complete the work.

#### **Part 8. Alternatives and Options To Consider**

- Do nothing – continue the current practice of relying on contracted work to achieve the goals of the CMOM Rehabilitation Strategy. This is risky because some assets are already past their projected rehabilitation window and could fail while waiting for their planned rehabilitation window which would result in expensive emergency work. This puts SPU at high risk of not effectively managing our system, potentially not meeting the goals of

the program, increasing costs due to emergency work and diverting resources from planned Capital Improvement Project (CIP) work.

- Increase production rate of contracted work – the sewer rehabilitation program depends on both contracted work (full-line replacement, spot repair, full-pipe lining) and crew work (spot lining & spot repair). Contracted work is delivered by Project Delivery and Engineering Branch (PDEB) as a CIP. PDEB has looked at trying to increase their production rate but concluded that it would be difficult to shorten the project duration significantly due to the rigorous process for design, bid, build public works projects.

## 20. Water Asset Management and Seismic Program

<b>Focus Area</b>	Strengthening Our Utility’s Business Practices
<b>Goals</b>	Manage assets and risks optimally
<b>Strategy</b>	Address aging, undersized and at-risk facilities and infrastructure to ensure continuous service delivery
<b>Type</b>	Investment
<b>SPU Branch/LOB</b>	Water, Project Delivery and Engineering
<b>Executive Sponsor</b>	Alex Chen, Keri Burchard-Juarez
<b>Project Manager/Lead</b>	Bill Wells
<b>Reporting</b>	Quarterly
<b>Funding</b>	Continued capital baseline funding
<b>Last Update</b>	January 2021

### Part 1. Summary of the Investment

SPU owns and operates a regional water system comprised of a vast array of assets ranging from dams, treatment plants, transmission and distributions pipes, storage tanks, pump stations, and more. The original water system was put into service in 1901 and has been continually expanded and improved. Many assets are aging; the average age of distribution pipes is approximately 70 years old. Investment in the repair, rehabilitation, and replacement of Seattle’s aging water system via this continuing initiative is critical. In addition, SPU takes advantage of many opportunities to address water pipe issues in partnership with transportation improvements (with the Seattle Department of Transportation/SDOT), which can reduce roadway restoration costs and disruption to the community.

In addition to managing our assets, the water system needs to be seismically resilient. SPU completed a water system seismic study in 2019 aimed at increasing SPU’s resilience against earthquakes. The study estimated that during a catastrophic earthquake, SPU would completely lose water pressure within 16 to 24 hours and it could take more than two months to restore service to all customers. A seismic resiliency strategy was developed that contains short-term and long-term actions to reduce the extent and duration of an earthquake-induced water outage. SPU is implementing the study recommendations via continued implementation of this initiative.

### Part 2. Targeted Commitments and Performance Measures

<b>Milestones</b>	<b>Anticipated Outcomes</b>	<b>Year</b>
Replace 2 miles of distribution water main per year	Improved water distribution system	2025-2030
Replace 650 water service lines per year	Improved water distribution system	2025-2030
Review every SDOT project for water distribution system improvement	Improved water distribution system	2025-2030

opportunities and partner on the project where possible.		
Complete seismic upgrades on the following SPU water assets: <ul style="list-style-type: none"> <li>• Magnolia Tank</li> <li>• Cedar River Pipeline at Renton</li> <li>• Eastside Reservoir</li> <li>• Riverton Reservoir</li> </ul>	Improved seismic resiliency	2025-2028

**Part 3. Financial Summary**

The current six-year combined Capital Improvement Plan (CIP) includes funds for the asset management and seismic resilience projects in this initiative. This includes water main replacement, service line replacement, and distribution and transmission system seismic work. Selected projects strive to balance system reliability with rate affordability.

Program Title	Water Asset Management and Seismic Program (\$000's)						
	2025	2026	2027	2028	2029	2030	TOTAL
Water main replacement (MC-SU-C1129)	19,460	26,550	32,535	29,811	37,415	40,215	185,986
Service line replacement (MC-SU-C1109)	7,707	7,938	8,176	8,422	8,650	8,884	49,777
Transportation Project Opportunities (MC-SU-C4119)	15,472	9,746	3,607	3,500	5,000	5,000	42,325
Distribution System Seismic Improvements (MC-SU-1139+Magnolia Tank)	8,395	7,660	2,587	450	500	10,000	29,592
Transmission System Seismic Improvements (MC-SU-C1210)	8,570	14,657	18,236	13,650	16,700	15,650	87,463
<b>Total Baseline Capital</b>	<b>59,604</b>	<b>66,604</b>	<b>65,141</b>	<b>55,833</b>	<b>68,265</b>	<b>79,749</b>	<b>395,143</b>

**Part 4. Capacity Plan to Deliver (Existing/Capital Only)**

For SPU-led projects, existing staff and contracted resources will be used to complete the preliminary analysis, design, contracting and construction for the projects. Transportation opportunity projects are led by SDOT and driven by their funding and schedules, and therefore are less under SPU's control.

### **Part 5. Racial Equity Impact**

Each project in this portfolio assesses equity impacts through applying SPU's Race and Social Justice Toolkit. This allows the project team and SPU's EJSE advisors to assess and develop actions to promote race and social justice equity in implementing the project.

### **Part 6. Climate and Sustainability Impact**

These projects are critical for having a sustainable water system and supply. Each project also individually looks for ways to decrease our carbon footprint and improve climate change resiliency, while balancing costs that affect affordability.

### **Part 7. Affordability Impact**

SPU's project initiation and options analysis stages consider multiple project options in relationship to system needs, long-term maintenance, long-term durability, community impacts/benefits, cost, and more. SPU typically chooses the lowest life cycle cost in selecting the preferred project alternative to minimize costs to ratepayers.

### **Part 8. Alternatives and Options To Consider**

These programs were previously evaluated and are ongoing. No additional alternative analysis was complete for this SBP update.



## 21. Strategic Technology Plan

<b>SBP Focus Area</b>	Strengthening Our Utility’s Business Practices
<b>SBP Goals</b>	Manage assets and risks optimally.
<b>SBP Strategy</b>	Support a continuous improvement and innovation culture.
<b>Type</b>	Investment
<b>SPU Branch/LOB</b>	People Community & Culture
<b>Executive Sponsor</b>	Idris Beauregard
<b>Project Manager/Lead</b>	Natasha Papsoueva, Steve Lavender
<b>Reporting Cadence</b>	Quarterly
<b>Funding</b>	New Investment
<b>Last Update</b>	September 2023

### Background:

Technology plays a critical role in achieving SPU's Strategic Business Plan goals and informs the future of our work. In 2023 – 2024 SPU has begun planning for that future through the development and implementation of the SPU Strategic Technology Plan (SSTP). To support our essential services, a strategic technology plan is critical for ensuring that these services are delivered effectively, efficiently, and equitably. The purpose of SSTP is to enable a future-ready utility where technology empowers our employees to fulfill our commitment to people, communities, and the environment.

### **Part 1. Summary of the Investment**

This new investment focuses on the implementation of the strategic technology plan across SPU. Key technology goals and objectives that have been outlined in the plan include the following elements that will help guide strategic technology decision-making for the next three to six years:

- Align technology solutions with utility strategies and business goals.
- Ensure our technology investments deliver value.
- Reflect our CARES guiding principles in technology investments.

This plan will include initiatives that support the following focus areas:

- Cybersecurity
- Digital Customer Experience, Customer Information Systems, Customer Engagement
- Application Rationalization, Cloud
- Operational Technology, IT/OT support, IT/OT integration and interoperability
- Asset Planning, Management and Operations
- Advanced Technologies to Support Future Workforce
- Data Management, Analytics, BI

- Tech Governance, Project Planning and Project Delivery

**Part 2. Targeted Commitments and Performance Measures**

Major Milestones	Anticipated Outcomes	Timing
Implement sustainable solutions that benefit SPU staff to enhance efficiency, customer service, and response times	Increased efficiency, reduced response times, improved service quality	Ongoing effort – deliveries per project schedule
Continuously monitor technology performance to optimize systems for efficiency, resource allocation, and asset management	Improvement in technology performance and resource optimization	Quarterly reporting
Ensure compliance with relevant regulations and standards, including cybersecurity and data privacy	Compliance with regulations, ensuring data security and customer privacy	Ongoing as part of the governance and oversight

**Part 3. Financial Summary**

This financial summary is based on the annual capital funding level of the technology CIP (Capital Improvement Project) portfolio over recent funding cycles. Capacity to deliver is dependent on resource availability in Seattle IT and SPU.

Program Title	Technology CIP Portfolio (\$000's)						
Project Name	Overall Budget						
	2025	2026	2027	2028	2029	2030	TOTAL
Baseline O&M	2,500	2,500	2,500	2,500	2,500	2,500	15,000
Baseline Capital	15,000	15,000	15,000	15,000	15,000	15,000	90,000
<b>Total Baseline</b>	<b>17,500</b>	<b>17,500</b>	<b>17,500</b>	<b>17,500</b>	<b>17,500</b>	<b>17,500</b>	<b>105,000</b>

**Part 4. Capacity Plan to Deliver (Existing/Capital Only)**

Capacity plan to deliver is dependent on resource availability from Seattle IT and Seattle Public Utilities; however, SPU can and often does augment these resources with consultants. In the case that there is not enough staff to sufficiently fill a project team, divisions are encouraged to

open out-of-class or temporary positions to allow existing staff to dedicate more time to a project. Entire projects are not typically sourced outside the city but portions of them are. One to two years of planning typically elapses before a project hits the capital budget spending. Technology governance as part of SSTP will address how and which projects are prioritized, planned, and delivered.

### **Part 5. Racial Equity Impact**

The Technology CIP Portfolio includes many projects and initiatives. All projects are reviewed using the RSJ toolkit as part of the standard process when moving from the initiation phase to the options analysis/planning phase.

Recognizing the critical importance of equitable access to essential services, the initiatives resulting from the SSTP will enhance SPU's service delivery, ensuring that all customers benefit from reliable water, drainage & wastewater, and solid waste services. By leveraging advanced technology solutions, SPU can enhance its operations in ways that directly benefit marginalized communities. This plan will support equitable access to essential services by improving digital tools and online platforms that make it easier for ratepayers, regardless of racial or socioeconomic background, to access information, report issues, and pay bills conveniently. Furthermore, the support of improved data analytics can be harnessed to identify and address disparities in service distribution, ensuring that historically underserved neighborhoods receive necessary support and resources.

In addition, transparency in decision-making can be improved by utilizing technology for public engagement and feedback collection, ensuring that the voices of underrepresented communities are heard and considered in policy formulation. Ultimately, it will be a powerful tool in the pursuit of racial equity, inclusivity, and access for the communities SPU serves.

### **Part 6. Climate and Sustainability Impact**

SPU is developing strategies to help contribute to economic opportunity, enhance livability, and sustainability. SSTP initiatives support these goals in multiple ways.

- Implementation of advanced technology systems that allow SPU to detect and address leaks promptly and further promote water conservation.
- Stormwater management to promote smart systems that use sensors and data analytics to predict and respond to the impacts of weather events more effectively. This proactive approach helps mitigate the risks of flooding, which are becoming more prevalent due to climate change.
- Digital monitoring and analytics will empower SPU to optimize operations and provide even more reliable services.
- Improved community engagement will empower SPU to use technology to educate and involve our communities in water conservation, responsible solid waste sortation, and

environmental stewardship. Through online platforms and educational initiatives, we invite our customers to play an active role in sustainable practices.

By embracing technologies recommended in the SSTP Roadmap, we're ensuring that SPU paves the way for the future while also promoting affordability, maximizing community value delivering high-quality, sustainable utility services that positively impact the environment, economy, education, and overall well-being of the communities we serve.

About 50% of technology initiatives are put into place support lines of business:

- Drainage and Wastewater: programs that are part of the consent decree for Drainage and Wastewater to minimize flooding events, due to global warming.
- Water: Technology on the waterside is designed to utilize predictive analytics to utilize current water resources more efficiently.
- Solid Waste: technology is used to educate and communicate how we can meet our waste reduction goals.

### **Part 7. Affordability Impact**

By utilizing advanced technologies to improve efficiency across the Utility, the cost of delivering services is reduced. When SPU selects projects to implement, affordability is considered.

Affordability can show up in multiple ways in which SSTP projects are delivered, some include:

- Data that allows for cost analysis.
- Technology upgrades and innovation allow for reduction of maintenance of outdated systems. Some examples of this could include utilizing data analytics, real-time monitoring, and predictive maintenance, that will allow SPU to proactively identify and address issues, reducing the frequency and impact of service disruptions. This will lead to cost savings as fewer emergency repairs will be needed, allowing SPU to allocate resources more efficiently.
- The SSTP provides prioritization for projects so that work can be allocated, and project dollars spend in an effective way.
- SSTP initiatives enable customers to better access to information and control over utility usage. This transparency can encourage conservation, help ratepayers reduce their bills while also contributing to environmental sustainability. They also may enhance customer service through digital channels improving online portals and mobile applications to streamline billing and service requests. This makes it easier to interact with SPU, enhancing customer satisfaction and reducing administrative costs associated with manual processes.

### **Part 8. Alternatives and Options to Consider**

The Strategic Business Plan has been developed and implemented, there are no alternative options to consider at this point. SPU can weigh what technologies they choose to pursue

through this plan over the next six years. When considering options, SPU may continue the path of maintaining the current technology structures based on maintenance needs and regulatory requirements, or they may invest in technologies based on a future forward and innovation. The SSTP will ensure we make high quality decisions about our technology investments.

## Appendix B – Community Research and Outreach Summary

### Purpose

Seattle Public Utilities (SPU) conducted research and community outreach to engage and learn from customers and community members as part of the 2025-2030 Strategic Business Plan (SBP) Update process.

Insights gathered will help the utility better understand customer and community perspectives and plan for the future. More specifically, this work will inform content and language in the SBP, ongoing SPU service delivery, and engagement with customers and the community.

The research and outreach process had several important, defining characteristics:

- **Purposeful and respectful of people’s time and opinions:** Community members and customers are often asked to share their opinions, but rarely know how their feedback is used (if at all). To demonstrate respect for people’s time and input, research and outreach tools were kept brief and made accessible.
- **Inclusive:** Recognizing that typical research and public input tools often underrepresent segments of the population, SPU made a deliberate effort to be inclusive in its outreach. Seattle Public Utilities with the help of Department of Neighborhoods’ Community Liaisons (CLs), took purposeful steps to better reach historically underserved and non-English speaking communities.
- **Multi-pronged:** Customers, community members, businesses, and SPU employees had multiple opportunities to provide input: through the careful mining of existing research, a statistically valid online survey, a brief community survey that was available in print and online, the SPU website, social media, meetings with community leaders, and interaction at events. Materials were translated into multiple languages to enhance accessibility.
- **Efficient and adaptive:** The research and engagement teams were mindful of utility and community investments (time, resources, and focus) and ensured outreach was strategic, concise, convenient, and valuable. Outreach was designed to provide accessible tools that allowed people to submit feedback in ways that maximize convenience.
- **Meeting the community where they are:** Engagement strategies were tailored to meet the needs of diverse communities. This involved language considerations, in-language outreach, strategic event selection, and understanding the unique preferences of different groups. This strategy aimed not only to disseminate information but also to cultivate a genuine understanding of the community's pulse.

## About this Summary

This is a high-level summary of the research and outreach effort. Detailed reports are available describing each component in more detail.

## Overview

Research and outreach included four distinct efforts: Community outreach, background research (Voice of the Customer research), qualitative research (QualBoards) with customers, and a scientific survey of customers.



## Community Outreach

SPU conducted outreach throughout the summer and fall of 2023 to gather customer feedback on essential services and identify key priorities in the community. This engagement effort centered and aimed to amplify the voices of historically underrepresented groups to ensure the SBP Update addresses the needs of the diverse communities SPU serves.

SPU - in partnership with the Department of Neighborhoods (DON) - worked with CLs, independent contractors with deep community connections, to implement an engagement strategy that was accessible and equitable.

This engagement model centered on co-designing engagement tools, like informational flyers and the community survey, with CLs to create materials that were accessible and easy to understand. With these materials, SPU attended 13 events across all City Council districts to distribute the survey and collect feedback. CLs played a crucial part in event engagement as they broke down language barriers and were friendly, familiar faces for community members.

Through this engagement, SPU collected 409 survey responses and reached over 1,155 customers.

## Voice of the Customer Research

The Voice of the Customer (VOC) research is a comprehensive review of 15 recent and relevant regional research studies commissioned by SPU and others to better understand residential and business customer experiences, opinions, and preferences as well as employee perspectives. Source material included Seattle and regional surveys, interviews, and focus groups. The VOC research analyzed the voluminous body of existing research to extract strategic information that would benefit the strategic

planning process. A priority was placed on understanding customer satisfaction and examining whether the utility’s goals and values align with that of SPU customers.

The VOC presents findings from several key studies, offering an in-depth view of customer and community perceptions. By synthesizing these sources, the VOC research is crucial for guiding SPU's future strategies and operations.

### **Qualitative Research**

SPU partnered with Lund Faucett and Carter Research to facilitate QualBoards to gain deeper insights into customer perceptions and experiences regarding SPU services. This approach was chosen for its ability to engage diverse and often underrepresented audiences, offering a more inclusive and comprehensive understanding than traditional survey methods.

A QualBoard is an online bulletin board discussion group, akin to a focus group, where participants log in at their convenience over specified days to engage in moderated, interactive discussions. Research was conducted from February 28 to March 2, and engaged 30 participants.

Participants shared their experiences and opinions through written responses, providing authentic narratives and valuable insights. These findings are instrumental in shaping the SBP Update and enhancing our understanding of customer needs and priorities.

### **Customer Survey**

SPU also partnered with Lund Faucett and Carter Research to develop, implement, and analyze a comprehensive residential customer survey to better understand customer opinions regarding SPU knowledge, opinions, and preferences. The survey was fielded from November 13 to December 5, 2023, and garnered responses from 1,042 customers. The primary mode of data collection was an online survey (in English). Translated versions of the survey were provided in Chinese (traditional), Vietnamese, Spanish, Somali, Korean, Amharic, and Tagalog.

This survey, the first comprehensive residential customer analysis since 2017, establishes a new baseline of customer insights, enabling SPU to conduct regular research into the future to track and analyze customer trends over time. The survey design was informed by Qualboards, VOC research, and community outreach. Where appropriate, the survey methodology and instrument were aligned with Seattle City Light’s 2023 customer survey to allow for comparative analysis.



## Key Themes and Findings

Component	Description	Key Themes/Findings
<b>Community Outreach</b>	Gathered public input and engaged historically underrepresented and often underserved populations on SPU’s 5 key questions (n =1,555)	<ul style="list-style-type: none"> <li>• The community expressed appreciation for high-visibility services like drinking water, but there is limited awareness of the full suite of services SPU provides.</li> <li>• There is confusion around the effectiveness of recycling programs and waste sorting.</li> <li>• Affordability is top of mind for customers.</li> <li>• Customers emphasized the importance of simplicity in communications or resources with the utility.</li> <li>• Some found difficulty reaching representatives for questions or general information about SPU, especially if the customer was not a native English speaker. Increased Spanish services were requested most.</li> <li>• The removal of litter, graffiti, needles, illegal dumping, and other hazards is a service not often attributed to SPU but is a top-of-mind concern for many community members.</li> </ul>
<b>Residential Customer Survey</b>	Fielded a broad-based online survey of SPU customers to inform the plan, ongoing service delivery and customer engagement (n=1,042)	<ul style="list-style-type: none"> <li>• There’s strong overall satisfaction with SPU’s services and low levels of dissatisfaction. Drinking water continues to be valued most highly and access to clean, safe drinking water is very important to a strong majority (88% say it’s ‘very important.)</li> <li>• Services provided by Seattle Clean City are top-of-mind and customers would like to see more done to address litter, garbage and dumping.</li> <li>• While SPU is viewed favorably and described as reliable, affordability is a strong concern and customers would like to see SPU do more to address costs and fees.</li> <li>• There are ample opportunities to improve SPU’s brand awareness—78% believe electricity is one of SPU’s services.</li> <li>• Opportunities also exist to improve customer awareness regarding SPU’s work to prepare for and mitigate climate change, protect health and the environment by moving dirty water out of homes and businesses, and ensure everyone has fair access to SPU services.</li> <li>• While awareness of financial assistance programs is high at 82%, renters are more challenging to reach and have lower levels of awareness around these programs.</li> </ul>
<b>QualBoards</b>	Qualitative research with SPU customers, with	<ul style="list-style-type: none"> <li>• There’s overall satisfaction with SPU and strong confidence in the safety and reliability of Seattle drinking water.</li> </ul>

	<p>oversample of BIPOC, central/south Seattle and younger respondents (n=30)</p>	<ul style="list-style-type: none"> <li>• Litter, dumping and uncontained garbage are a stronger concern.</li> <li>• There’s some confusion about the services SPU provides.</li> <li>• Overall impressions of SPU are mostly positive and SPU’s services are appreciated.</li> <li>• SPU’s persona is friendly, helpful, efficient and service-oriented.</li> <li>• Growth, environmental advances and water supply issues are seen as SPU’s biggest challenges.</li> <li>• While some participants were positive about SPU’s efforts around climate change, sustainability, and growth, many lacked awareness.</li> <li>• There’s an opportunity to improve awareness of financial assistance programs, community engagement opportunities, and conservation assistance.</li> <li>• The development of a strategic business plan is seen as important.</li> </ul>
<p><b>Voice of the Customer Research</b></p>	<p>Comprehensive review of research studies commissioned by SPU and others to better understand residential and business customer experiences, opinions, and preferences as well as employee perspectives</p>	<ul style="list-style-type: none"> <li>• High satisfaction with SPU services and desire for continued investment in services and infrastructure.</li> <li>• Visible SPU services like drinking water and recycling are well-regarded; however, Clean City services are less associated with SPU and there is notable dissatisfaction with the handling of city cleanliness issues.</li> <li>• Affordability of rates, rate predictability, cutting costs, and finding efficiencies are concerns.</li> <li>• Environmental leadership is a regional value and source of pride.</li> <li>• Positive perceptions of SPU’s approach to environmental stewardship exist, yet many lack awareness of SPU’s efforts around climate change and sustainability.</li> <li>• SPU employees feel valued and desire more opportunities for training and advancement. Cross-divisional communication remains an area for development.</li> <li>• Public preference is evident for public or community-owned utilities, with a strong belief in the importance ensuring access to healthy and affordable necessities.</li> <li>• Businesses appreciate opportunities to save money and desire streamlined customer service experiences.</li> </ul>

### Considerations and Opportunities

The insights gleaned from SBP research and outreach raise some issues for further consideration and potential opportunity areas that SPU will be working to address. Specifically:

1. How can we ensure that insights from outreach and research are shared effectively within the utility and used to inform service delivery and future outreach?

2. How can we close the feedback loop with the community, sharing the results of this and other research and outreach?
3. Are there opportunities SPU wants to pursue to receive more focused input?
4. Are there opportunities to coordinate research and outreach across SPU's lines of business to minimize fatigue/lack of participation and maximize organizational knowledge and continual improvement?

### **Additional Resources**

The following detailed research and outreach summaries are available:

- Voice of the Customer Research Report (February 2024)
- Qualitative Research Report (April 2023)
- Community Outreach Report (December 2023)
- Residential Customer Survey Report (February 2024)

## Appendix C – Financial Forecast

### Key Rate Drivers

The rate paths for each fund contain key assumptions regarding debt issuances, capital accomplishment, consumption, and the Utility Discount Program. Below is a summary matrix of the primary assumptions. Each fund has additional assumptions that are unique to its structure, which are explored in the following sections.

Overall, the Utility is seeing demand return to pre-COVID levels in all services - residential-, commercial-, and developer-related. Simultaneously, increases in the Utility Discount Program are anticipated and included in the projected rates. The following table highlights key assumptions over the six-year period.

### Proposed Strategic Business Plan Rate Path

	<u>2025</u>	<u>2026</u>	<u>2027</u>	<u>2028</u>	<u>2029</u>	<u>2030</u>	<u>2025-30</u>
Water	2.0%	2.0%	6.3%	3.3%	6.5%	3.8%	<b>4.0%</b>
Wastewater	5.0%	5.0%	5.0%	6.2%	7.0%	5.1%	<b>5.5%</b>
Drainage	5.0%	5.0%	5.1%	6.6%	6.3%	7.2%	<b>5.9%</b>
Solid Waste	2.5%	3.1%	3.4%	3.4%	3.8%	2.5%	<b>3.1%</b>
Combined	<b>3.7%</b>	<b>3.9%</b>	<b>4.9%</b>	<b>5.0%</b>	<b>6.0%</b>	<b>4.6%</b>	<b>4.7%</b>
	Approved rate legislation that is currently in effect						

	<b>Water</b>	<b>Drainage &amp; Wastewater</b>	<b>Solid Waste</b>
<b>Average Interest Rate on Bonds</b>	2025-2030: 5.0%	2025-2030: 5.0%	No planned debt issuances
<b>Capital Accomplishment Rate</b>	80%	80%*	80%
<b>Consumption</b>	Residential: 0.0% Commercial: 0.0%	Residential: -3.0% Commercial: +3.0%	Residential: -1% Commercial: -4% Transfer Stations: 1%
<b>Utility Discount Program Accounts</b>	2025: +2,500	2025: +2,500	2025: +2,500

\*Drainage & Wastewater Fund accomplishment rate is 80% for all projects except for the Ship Canal project, which is at a 95% accomplishment rate.

### *Utility Discount Program*

The City of Seattle has one of the most robust Utility Discount Programs (UDP) in the country. SPU provides a 50% credit on all qualifying customer bills. The Utility also supports an Emergency Assistance Program (EAP) that provides relief for up to 50% of the bill two times per year for qualifying households. For more information about the UDP and EAP programs, please visit [seattle.gov/utilities/your-services/discounts-and-incentives](http://seattle.gov/utilities/your-services/discounts-and-incentives). The chart below provides historical and projected annual enrollment.

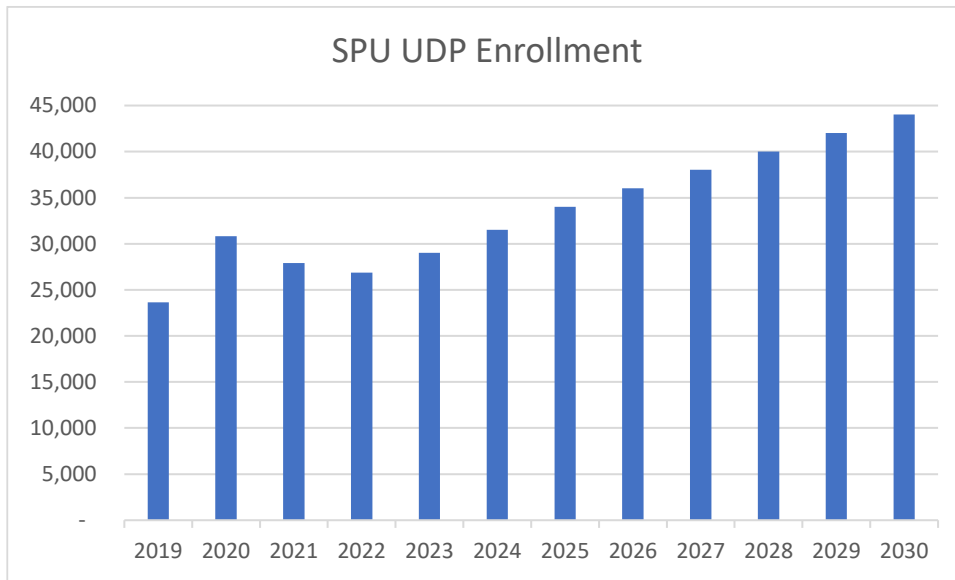

The following sections go into detail for each individual Fund. All three Funds entered 2024 in a healthy financial position, which is anticipated to allow them to weather the economic impacts over the course of the SBP 6-year period.

### **Water**

Water Fund rate projections are anticipated to increase an average of 4.0% per year during the period of 2025-2030. The projected average rate increase for the first 3 years of the SBP is 3.4%; the average increase over the second half of the SBP is 4.5%.

During the six-year plan, operational expenses are projected to increase 4% per year. Non-rate revenues and cash reserves help offset the above-inflation cost increases. In addition, several bond series will be paid in full, reducing on-going debt service. The 1997 and 1999 bonds will be fully paid in 2026 and 2029, respectively. As part of the debt service management plan, the 2024 bond issue is projected to have no principal payment in 2029, with a double principal payment in 2030. This minor adjustment will create a smoother debt service profile when combined with existing debt service.

### *Key Rate Drivers*

The key rate driver for the Water Fund is increasing operational expenses (O&M). Operating cash balance is the binding constraint, or the financial policy that is just met, for the Plan period. For this period, Water’s operating cash balance is above the policy target. However, rating agencies do not view large cash decreases favorably; therefore, the Plan has cash remain constant until 2029. In 2029, there is a \$6M drawdown to mitigate a large potential rate increase. The drawdown is expected to be replaced by 2031 through planned balance increases.

### *Revenue and Expenditure Assumptions*

<b>2025-2030 SBP</b>	<b>2025</b>	<b>2026</b>	<b>2027</b>	<b>2028</b>	<b>2029</b>	<b>2030</b>
Total Retail Rate Revenue (\$M)	241.1	246.2	262.0	270.8	288.7	300.0
Annual Change	3.7%	2.1%	6.4%	3.4%	6.6%	3.9%
Retail Consumption (M CCF)	26.6	26.6	26.6	26.6	26.6	26.6
Annual Change	1.5%	0.0%	0.0%	0.0%	0.0%	0.0%
<b>Annual Rate Increase</b>	<b>2.0%</b>	<b>2.0%</b>	<b>6.3%</b>	<b>3.3%</b>	<b>6.5%</b>	<b>3.8%</b>
<b>Retail Rate Revenue (\$M)</b>	<b>241.1</b>	<b>246.2</b>	<b>262.0</b>	<b>270.8</b>	<b>288.7</b>	<b>300.0</b>
Debt Service (\$M)	78.7	81.1	84.0	86.8	94.5	90.2
O&M incl. Taxes (\$M)	215.3	224.9	235.5	244.4	256.4	266.7
Cash-to-CIP (\$M)	30.0	25.1	26.4	25.2	28.0	25.4
Less: Wholesale Revenue (\$M)	-58.4	-59.7	-59.7	-59.7	-59.7	-59.7
Other Net Expense / (Revenue) (\$M)	-24.4	-25.2	-24.3	-25.8	-30.5	-22.6

\*Other Net Expense/Revenue include taps and capital contributions, other non-operating income, miscellaneous charges, and changes in cash balance.

#### *Risks and Watch Areas for Rate Path*

For the Water Fund, the most likely risks are poor summer weather and a prolonged recession. Long-term risks include climate change and seismic events.

#### *Financial Indicators*

The Water Fund is expected to meet or exceed all financial policy targets during the SBP period.

<b>(\$ in millions)</b>	<b>2025</b>	<b>2026</b>	<b>2027</b>	<b>2028</b>	<b>2029</b>	<b>2030</b>
Debt Service Coverage	2.0	1.9	1.9	1.8	1.8	1.9
Net Income	\$29.4	\$23.2	\$23.8	\$19.7	\$21.5	\$21.7
Cash-to-CIP	23%	20%	20%	20%	20%	20%
Cash Balance	\$110.0	\$110.0	\$110.0	\$110.0	\$104.0	\$107.0
RSF Withdrawals/(Deposits)	\$0.0	\$0.0	\$0.0	\$0.0	\$0.0	\$0.0
Bond Issues	\$106.7	\$107.8	\$108.5	\$109.9	\$112.3	\$106.3
Debt Service	\$78.7	\$81.1	\$84.0	\$86.8	\$94.5	\$90.2
Consumption (ccf, millions)	26.6	26.6	26.6	26.6	26.6	26.6

#### **Drainage & Wastewater Fund**

The Drainage & Wastewater Fund (DWF) receives revenue from two separate sets of rates. Wastewater rates are projected to increase an average of 5.5% per year during the period of 2025-2030. The projected average rate increase for the first 3 years of the SBP is 5.0%; the average increase over the second half of the SBP is 6.1%. Drainage rates are projected to increase an average of 5.9% per year during the period of 2025-2030. The projected average rate increase for the first 3 years of the SBP is 5.0%; the average increase over the second half of the SBP is 6.7%.

Cash is being used to reduce the rate path over the next few years. This cash is the product of unspent capital funds, lower than projected O&M expenditures, and surplus revenues generated by higher-than-expected demand. The specific use of this cash is to offset the consent-decree driven spike in the DWF

capital program, keeping the Fund’s periodic debt issuance related rate increases closer to a steady, long-term baseline. Because the cash is being used to offset the investment spike, as opposed to offset baseline investment or to pay for current O&M expenses, there is no bow-wave effect on rates, which would be the case when, for example, expenses increase annually and steadily but rate increases are held flat.

### *Key Rate Drivers*

The key rate driver for the DWF is increasing capital investment necessitated by consent decree programs. To offset the investment cost spike these programs are creating, the DWF will spend down operating cash to 100 days of operating cash on hand, a level that, through consultation with SPU’s financial advisors, was deemed adequate to defend the Fund’s bond ratings and inexpensive access to capital. Through 2030, 100 days of operating cash is approximately \$179 million, and this becomes the binding constraint, or the financial policy that is just met, for the SBP period.

### *Revenue and Expenditure Assumptions*

<b>2025-30 SBP</b>	<b>2025</b>	<b>2026</b>	<b>2027</b>	<b>2028</b>	<b>2029</b>	<b>2030</b>
Wastewater Rate Revenue (\$M)	402.1	422.7	443.9	471.1	504.8	533.2
Annual Change	5.2%	5.1%	5.0%	6.1%	7.1%	5.6%
Consumption (M CCF)	20.9	20.9	21.0	20.9	21.0	21.1
Annual Change	-0.2%	0.1%	0.0%	-0.1%	0.2%	0.5%
<b>Annual Rate Increase</b>	<b>5.0%</b>	<b>5.0%</b>	<b>5.0%</b>	<b>6.2%</b>	<b>7.0%</b>	<b>5.1%</b>
Drainage Rate Revenue (\$M)	211.2	221.8	232.9	248.8	264.2	283.1
<b>Annual Rate Increase</b>	<b>5.0%</b>	<b>5.0%</b>	<b>5.0%</b>	<b>6.8%</b>	<b>6.2%</b>	<b>7.1%</b>
<b>Retail Rate Revenue (\$M)</b>	<b>613.3</b>	<b>644.4</b>	<b>676.8</b>	<b>719.9</b>	<b>769.0</b>	<b>816.3</b>
Debt Service (\$M)	84.8	94.2	101.8	114.1	123.7	129.8
O&M inc. Taxes (\$M)	273.4	289.0	301.7	313.3	327.2	347.8
Treatment (\$M)	218.5	231.8	247.9	265.3	283.8	305.0
Cash-to-CIP (\$M)	71.1	81.9	66.6	44.2	42.0	71.3
Other (\$M)	-34.5	-52.5	-41.2	-16.9	-7.6	-37.6
King County Treatment Rate <sup>1</sup>	5.75%	5.75%	6.50%	6.50%	6.50%	7.00%

### *Risks and Watch Areas for Rate Path*

For the DWF, the most likely risks are capital project cost overruns, increased interest rates, and increases in King County treatment rates. The DWF has entered a period of intense capital investment, requiring the Fund to access capital markets frequently over the SBP period. Both wastewater and drainage rates have a treatment and system component. Treatment expense is the Fund’s largest expenditure obligation. King County wastewater treatment rates are projected to increase annually during the SBP period as the County continues an intense capital program driven by asset management and regulatory requirements. Long-term risks include climate change and seismic events.

### *Financial Indicators*

The DWF is expected to meet or exceed all financial policy targets during the SBP period.

<sup>1</sup> King County Treatment Rate: 2024 is adopted; 2025 – 2030 are based on King County projections.

(\$ in millions)	2025	2026	2027	2028	2029	2030
Debt Service Coverage*	2.6	2.5	2.4	2.4	2.4	2.4
Net Income	\$39.4	\$41.6	\$40.8	\$53.1	\$64.2	\$75.2
Cash-to-CIP	40%	41%	33%	25%	25%	31%
Cash Balance	310.0	258.8	216.9	206.4	203.1	179.0
Bond Issues	\$65.7	\$82.5	\$133.3	\$137.8	\$147.2	\$177.0
Debt Service	\$84.8	\$94.2	\$101.8	\$114.1	\$123.7	\$129.8
Consumption (ccf, millions)	20.9	20.9	21.0	20.9	21.0	21.1

\*Debt Service Coverage is less taxes.

### Solid Waste

Solid Waste rates are projected to increase an average of 3.1% per year during the period of 2025-2030. The projected average rate increase for the first three years of the SBP is 3.0% and the average increase over the second half of the SBP is 3.2%. These rate increases are at or just slightly above inflation and are consistent with the annual increases in operational expenses.

The SBP rate path considers the latest capital projects plan, and the Solid Waste fund has sufficient balances to cash fund all capital projects. This eliminates the need for bond issues and helps to reduce the rate path. SWF does not anticipate a bow wave of rate increases in the future.

#### Key Rate Drivers

The key rate driver for the Solid Waste Fund is increasing operational expenses (O&M). Cash balances are currently the binding constraint, or the financial policy that is just met, for the rate period. The internal target for the Solid Waste Fund is currently 45 days operating expense, which is just met in 2029 at \$33 million. The cash balance target is set to ensure that the fund has sufficient cash on hand to pay operating expenses, as well as provide flexibility in case of financial hardship or major policy changes.

#### Revenue and Expenditure Assumptions

2025-2030 SBP	2025	2026	2027	2028	2029	2030
Total Retail Rate Revenue (\$M)	266.8	278.7	283.6	295.3	309.4	319.6
Annual Change	4.03%	4.46%	1.76%	4.13%	4.76%	3.30%
Annual Rate Increase	<b>2.50%</b>	<b>3.10%</b>	<b>3.40%</b>	<b>3.40%</b>	<b>3.80%</b>	<b>2.50%</b>
<b>Retail Rate Revenue (\$M)</b>	<b>266.8</b>	<b>278.7</b>	<b>283.6</b>	<b>295.3</b>	<b>309.4</b>	<b>319.6</b>
Debt Service (\$M)	6.0	4.0	3.5	3.2	2.4	2.4



O&M incl. Taxes (\$M)	273.3	272.9	271.6	282.6	301.4	297.6
Cash-to-CIP (\$M)	27.2	9.1	13.5	7.7	16.1	6.4
Other Net Expense / (Revenue) (\$M)*	-48.3	-17.9	-16.2	-9.6	-22.8	1.1

\*Other Net Expense/(Revenue): non-operating income, miscellaneous charges, and changes in cash balance.

### Risks and Watch Areas for Rate Path

For the Solid Waste fund, potential risks include market forces and contract risk. Solid waste collection processing, and transfer rely on contractors. There is a risk during contract renewals and negotiations, as well as risk if contractors run into any issues that could impede their ability to provide services.

Market forces could drive risk for the Solid Waste fund. Recycling markets and commodity revenues are subject to external economic forces. Creation of new services could require new solid waste facilities or additional contracting costs.

### Financial Indicators

The Solid Waste Fund is expected to meet or exceed all financial policy targets during the SBP period.

(\$ in millions)	2025	2026	2027	2028	2029	2030
Debt Service Coverage	4.1	4.1	4.2	4.3	4.6	4.6
Net Income	\$11.3	\$10.1	\$10.9	\$11.3	\$14.0	\$12.6
Cash-to-CIP	100%	100%	100%	100%	100%	100%
Cash Balance	\$61.7	\$53.4	\$46.9	\$46.6	\$33.3	\$44.0
RSF Withdrawals/(Deposits)	\$0.0	\$0.0	\$0.0	\$0.0	\$0.0	\$0.0
Bond Issues	\$0.0	\$0.0	\$0.0	\$0.0	\$0.0	\$0.0
Debt Service	\$6.0	\$4.0	\$3.5	\$3.2	\$2.4	\$2.4

### Fund Financial Policies

Metric	WF	DWF	SWF
Debt service coverage			
- Adopted	1.7x	1.8x	1.7X; 1.5X (less taxes)
- Internal	NA	2.0X; 1.5X (less taxes)	NA
Debt-to-Asset Ratio	NA	<=70 percent	NA
Cash-financed CIP	20 percent over rate period; 15 percent minimum in a given year	25 percent minimum 4-yr rolling average	Greater of \$4.0 million or 10 percent of CIP

<b>Net Income</b>	Generally positive	Generally positive	Generally positive
<b>Year-end cash balance</b>			
- Adopted	One-month current year operating expense (\$17M)	One-month treatment expense (\$17M)	20 days contract expense (\$8M)
- Internal	120 days operating cash including taxes (\$71M)	100 days operating cash (\$135M)	45 days operating cash (\$29M)
<b>Variable Rate Debt</b>	<=15 percent	<=15 percent	<=15 percent

**Bill Tables**

The tables below project the typical monthly cost for the following average customers. SPU customers are billed every two months.

Typical Monthly Cost  
Examples

**Single-Family Home**

	<b>2025</b>	<b>2026</b>	<b>2027</b>	<b>2028</b>	<b>2029</b>	<b>2030</b>
Water	\$50	\$51	\$54	\$56	\$60	\$62
Wastewater	\$83	\$87	\$92	\$97	\$104	\$109
Drainage	\$63	\$66	\$69	\$74	\$78	\$84
Solid Waste	\$60	\$62	\$64	\$66	\$68	\$70
<b>Combined</b>	<b>\$256</b>	<b>\$266</b>	<b>\$279</b>	<b>\$293</b>	<b>\$310</b>	<b>\$325</b>
<b>Monthly change</b>	<b>\$11</b>	<b>\$10</b>	<b>\$13</b>	<b>\$14</b>	<b>\$17</b>	<b>\$15</b>

**Multifamily Unit**

	<b>2025</b>	<b>2026</b>	<b>2027</b>	<b>2028</b>	<b>2029</b>	<b>2030</b>
Water	\$28	\$28	\$30	\$31	\$33	\$34
Wastewater	\$77	\$81	\$85	\$90	\$96	\$101
Drainage	\$12	\$12	\$13	\$14	\$15	\$16
Solid Waste	\$30	\$31	\$32	\$34	\$35	\$36
<b>Combined</b>	<b>\$147</b>	<b>\$153</b>	<b>\$160</b>	<b>\$169</b>	<b>\$179</b>	<b>\$187</b>
<b>Monthly change</b>	<b>\$5</b>	<b>\$6</b>	<b>\$8</b>	<b>\$8</b>	<b>\$10</b>	<b>\$8</b>

**Convenience Store**

	<b>2025</b>	<b>2026</b>	<b>2027</b>	<b>2028</b>	<b>2029</b>	<b>2030</b>
Water	\$122	\$125	\$133	\$137	\$146	\$152
Wastewater	\$384	\$404	\$424	\$450	\$482	\$506
Drainage	\$152	\$160	\$168	\$179	\$191	\$204
Solid Waste	\$604	\$623	\$644	\$666	\$692	\$709
<b>Combined</b>	<b>\$1,263</b>	<b>\$1,312</b>	<b>\$1,369</b>	<b>\$1,433</b>	<b>\$1,510</b>	<b>\$1,571</b>
<b>Monthly change</b>	<b>\$44</b>	<b>\$49</b>	<b>\$58</b>	<b>\$64</b>	<b>\$77</b>	<b>\$61</b>



Utility affordability is a public policy issue affecting people’s ability to access essential services, and thus impacting their quality of life. Seattle Public Utilities is working to address the burden of utility bills by:

- Establishing transparent utility pricing and rate structures;
- Improving and innovating customer assistance programs to address low- and fixed-income customers;
- Seeking state and federal funding to further support low-income customers;
- Maximizing community returns on SPU investments through process efficiencies; and
- Prioritizing programs and investments to meet needs and maximize value to all SPU customers.

### Challenges faced by customers:

#### Low-income customers are disproportionately impacted by utility bill increases

As Seattle experiences growing costs of living and income disparity, SPU customers face significant affordability concerns. According to a 2023 University of Washington report, a household of four needs over \$84,000 a year to pay for basic living needs. In contrast, the region’s second and third most common occupations, fast food workers and counter workers, earn a median income of \$35,000.

A quarter of households in the Duwamish and Beacon Hill neighborhoods have household incomes below UW’s Self-Sufficiency Standard; 30% of households in Northeast Seattle have household income below the Self-Sufficiency Standard. Affordability will continue to being a challenge for many customers: SPU bills have outpaced inflation and income growth since 2010, growing at an average rate of 5.5 percent, compared to a 3.0 percent inflation rate (as measured by the Consumer Price Index, CPI) and 4.8 percent income growth (change in median income). Low-income customers and traditionally underserved communities, including communities of color, are disproportionately impacted.

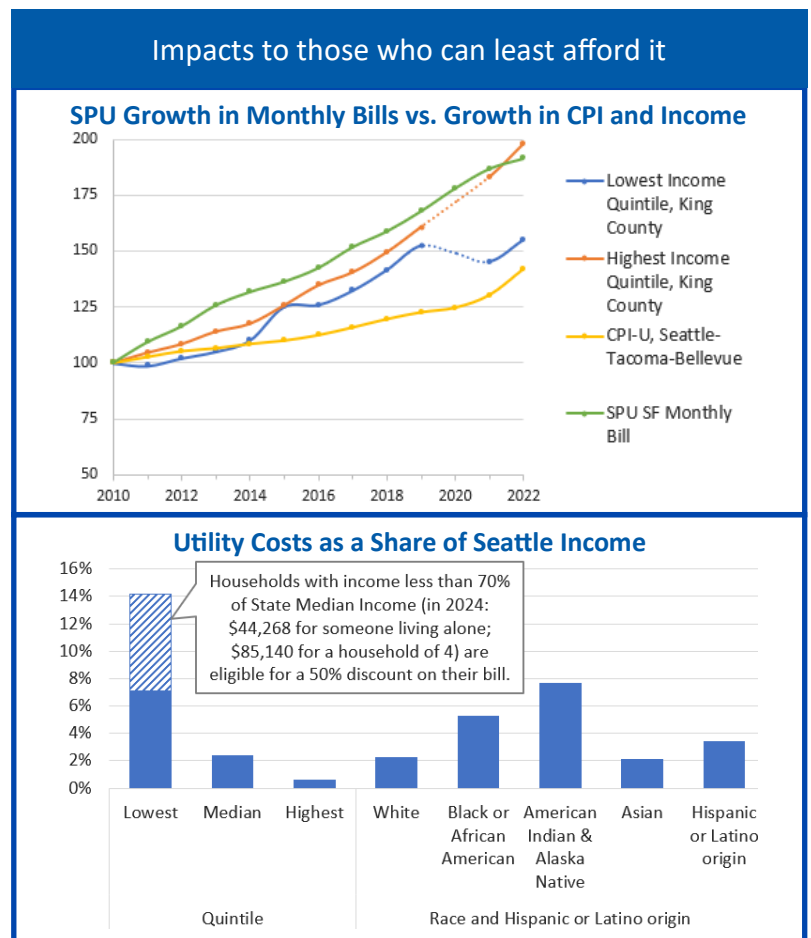

Sources: Income: American Community Survey 1-year samples; CPI: Bureau of Labor Statistics

### Challenges faced by SPU: Water and waste management demands

SPU faces several challenges as it delivers essential water, drainage and wastewater, and waste services that are costly to address.

- Aging or vulnerable infrastructure
- Wastewater treatment costs from the regional system
- Culvert removal and replacement
- Water pollution from sewer overflows during high rainfall events
- Pollution remediation, including Superfund sites and addressing emerging contaminants
- Climate change
- Flooding impacting our drainage and wastewater systems

## Affordability and accountability efforts

SPU's Affordability and Accountability (A+A) Strategic Plan identifies the utility's strategic priorities and commitments for improving SPU's overall ratepayer affordability and business performance. SPU's overall goal is to deliver the highest quality service at the lowest predictable rate and to be transparent about how rate dollars are spent. **Affordability** outcomes focus on overall and individual "ability to pay". **Accountability** outcomes focus on meeting commitments and demonstrating results.

Overall, A+A work is characterized by focused actions, large and small, made across the organization as part of everyday work.

### Affordability results

#### Minimizing costs to SPU

In the face of high inflation from factors such as health care, construction, and labor, as well as facing pass-through rate increases from King County's sewer services, SPU has worked to reduce its costs by securing low-interest loans, refinancing bonds, renegotiating contracts, and improving capital project coordination and funding policies. These efforts have allowed SPU to keep rate increases to below its 5% target.

From 2019-2022,

- Low-interest WIFIA funding and SRF loans saved SPU over \$85 million,
- Bond refinancing saved SPU over \$45 million, and
- Renegotiating Solid Waste contracts saved \$5 million per year.

#### Improving SPU's customer assistance programs

To ensure equitable access to utility services to all, SPU has focused on providing significant support to the most vulnerable customers. SPU has taken proactive action to increase customer affordability assistance by:

- Continuing engagement with community partners to increase enrollment in the Utility Discount Program;
- Expanding emergency bill assistance;
- Ensuring water access during extreme heat events;
- Preventing shutoffs during COVID recovery by allowing flexible repayment of delinquencies over longer periods of time; and
- Embarking on a comprehensive evaluation of the utility bill assistance programs in partnership with Seattle City Light to inform future program improvements.

### Accountability results

#### Increasing transparency through reporting

SPU's efforts to improve accountability include increased transparency through reporting. Two key efforts to ensure transparency are:

1. Strategic Business Plan progress reporting through regular quarterly reports presented to the SPU Customer Review Panel and posted publicly.
2. Reporting on the status of SPU capital infrastructure projects as needed online and through publicly-available media channels whenever there are significant changes or key milestones are met.



For more information on SPU's Affordability and Accountability accomplishments and strategic plan, please visit <https://www.seattle.gov/utilities/about/plans/strategic-business-plan/plan-documents>



Seattle Public Utilities Customer Review Panel

c/o Danielle.Purnell@seattle.gov

P.O. Box 34018, Seattle WA 98124-4018

May 10, 2024

**To: Councilmember Joy Hollingsworth, Chair, Parks, Public Utilities, and Technology  
Seattle City Council**

**RE: Seattle Public Utilities Customer Review Panel Comments on the Proposed SPU  
Strategic Business Plan Update for 2025-2030**

---

The Customer Review Panel (CRP) is pleased to submit our comments on Seattle Public Utilities' (SPU) 2025 - 2030 Strategic Business Plan (SBP). This letter fulfills the CRP duties as described in Resolution 31800. The CRP has held 18 meetings over 19 months to prepare this letter. We have worked diligently and effectively with SPU staff to understand projects, initiatives, and investments as well as to learn about financial and broader economic considerations that impact rates and SPU's work.

### **Process**

This year, to better organize our comments and to reflect the values of the collective group more accurately, the CRP embarked on a multi-month strategic framework discussion where we centered our core values and strategic priorities; understood key issues; articulated goals and desired investments. Our hope is that this level of organization better highlights critical needs and where the CRP thinks SPU should emphasize its investments. Beyond this letter, we look forward to continuing to work with SPU staff to use this framework to inform future SBP updates and quarterly reporting to the CRP, Mayor's Office, and City Council.

### *Core Values*

In 2021-2022, in partnership with SPU and the Department of Neighborhoods (DON), the CRP engaged in a broad membership recruitment effort. This resulted in a group of community





members that includes small business owners, multi-family and single-family residential ratepayers, retired experts, and those with an interest in community issues and SPU's work with the unhoused. In 2022, we worked together to develop a set of core values for the new group of CRP volunteers. These core values help us align under a common understanding of what guides our work. They are:

- **Learning** - We embrace a sense of learning, curiosity, and mutual growth.
- **Connection to Community** - We center our connection to our communities and lived experience.
- **Impact** - We center impact to ratepayers, our neighbors, and all Seattleites.
- **Equity & Sustainable Development** - We embrace equity and sustainable development as key north stars in our work.
- **Representation** - We understand that representation matters and assume good intentions from one another.
- **Responsiveness** - We commit to be responsive to one another and to the current context in which our work is taking place.
- **Trust** - We commit to building trust with one another as a critical avenue to grow relationships and best serve our communities.

### *Strategic Priority Areas*

Using our core values as a guide, the CRP defined four strategic priority areas for investment and focus. The following act as a guide for the rest of our letter and represents where the CRP thinks that SPU should put disproportionate focus, resources, and interest as part of the SBP update. The recommendations below do not reflect everything that SPU does or should do, nor does it diminish important investments and programs that are underway. For each strategic priority area, the CRP defined a goal statement that represents an aspirational future state to guide SPU in their work. The CRP strategic priority areas are:

- **Affordability and Accessibility** - SPU provides equitable and affordable access to basic services.





- *Asset Management and Infrastructure* - SPU successfully maintains existing assets and builds resilient infrastructure to meet future system needs.
- *SPU Workforce* - SPU staff is as diverse as the community it serves, is trained, supported, and fulfilled in their work.
- *Climate Resiliency* - SPU is prepared for the impacts of climate change with resilient infrastructure and actively prioritizes overburdened communities.

Below we have detailed specific key issues and investments that we believe require the most investment and focus over the next three years.

### **CRP Recommendations**

#### *Affordability and Accessibility*

Affordable and equitable access to basic services is critical to the vibrancy of Seattle's communities, residents, and ratepayers. During our review process of current SPU programs and initiatives, the CRP focused on key issues pertaining to increasing equitable access to basic services and understanding the need for clean and accessible water for Seattle's unhoused community. We also focused on service impacts to small businesses and residential property owners including the cost of maintaining and improving critical infrastructure such as side sewers. The CRP was eager to learn more about the Side Sewer Assistance Program and was particularly interested in how SPU could expand its zero interest programs to assist more home and business owners.

The CRP participated in several thoughtful conversations on expanding services and partnerships while minimizing the impact on utility rates. Using our core values to guide the conversation, the CRP was able to center conversations around impacted ratepayers leading with equity and sustainability. We applaud SPU for their efforts to work with customers impacted by COVID-19 to avoid going into arrears by developing payment plans. The CRP believes that SPU should continue its work in expanding programs like the Utility Discount Program (UDP) and the Emergency Assistance Program (EAP). In addition, SPU should continue to proactively seek out additional community partnerships with the goal of growing







accessibility and maintaining affordability through the Alternative Funding and Finance initiative.

The CRP also understands the growing demand and need for clean city and support services for the unhoused and urges the Mayor and Council to prioritize additional general fund resources to meet the community need.

Finally, the CRP encourages the Council to continue its conversations on ways to reduce or eliminate the water utility tax.

### *Asset Management and Infrastructure*

The CRP recognizes the need for a sustainable, well preserved, and functioning asset management and infrastructure program. The CRP believes that increased investments in preservation of assets and building redundancies throughout the system will better prepare SPU in the case of a seismic event or another major emergency. The CRP acknowledges that SPU has an increasing list of deferred maintenance projects and mission-critical aging infrastructure that should be modernized or replaced. We agree with SPU's definition of "critical need" to mean infrastructure investments to meet health and environmental regulatory requirements, those that are necessary to support baseline work, and those responding to operation and maintenance needs listed in the SPU's most recent Capital Improvements Program Budget (CIP).

To support these growing needs, the CRP welcomes continued work in the Duwamish Valley with SPU's focus on combined sewer overflow prevention and coastline management. Recent rainfalls and sea level rises, particularly in South Park, have meant historic king tide levels resulting in damage to homes, businesses and altering the lives of hundreds of residents. The CRP also prioritizes continued investments in the water asset management and seismic resiliency program.

The CRP had robust discussions about the Automated Metering Infrastructure (AMI). Panel members strongly agreed with the importance of pursuing AMI technology to modernize and replace aging metering assets and achieving SPU's carbon reduction commitments. A majority of members of the CRP, however, felt planning for this investment should continue but implementation could be shifted to later years in favor of more urgent infrastructure needs. This shift would keep the proposed rate path slightly lower in an unsure economy and may benefit





from future technologies that could lower the cost of the AMI transition and implementation. We look forward to continuing our conversations around the AMI program, particularly plans for the re-deployment of the meter reader workforce and technological advancements.

### *SPU Workforce*

A well supported and fully staffed SPU is critical in advancing the needed work for the utility. With increases in retirements and shifts in the ability to retain and recruit workers, the CRP is interested in seeing an ongoing effort to fill essential vacancies and critical front-line functions. Workforce recruitment programs should expand to include more robust training and apprenticeship partnerships with clear pathways to good paying jobs and well-defined career ladders. The CRP is strongly in support of pay equity and increased employee wellness programs at SPU as well as the provision of adequate facilities for all staff. As part of this update, the CRP supports continued work in the SPU employee life cycle initiatives and pay equity work. The CRP also believes that investments in the North One Water facility and field engineering staffing improvements will provide more robust working conditions as well as sustainable and predictable staffing levels.

Following the CRPs core value of equity, panel members support SPU's efforts to grow the diversity of its staff and encourage the agency to continue to grow in how it tracks and collects demographic data. In particular, the CRP is interested in SPU further disaggregating its employment data by race, ethnicity, management, and front-line workers.

### *Climate Resiliency*

Making proactive improvements to critical systems affected by climate change is one of the most impactful investments that SPU can make. The CRP particularly leaned into priorities that can help alleviate burdens on the system and that are innovative and future-thinking. In this plan, the CRP supports the continued work in the Duwamish Valley to adequately protect this community from flooding. The CRP also urges increases in SPU's sustainability of operations and a maintained focus on its efforts to meet the 2030 Carbon Neutrality goals. Impactful community programs such as Seeds of Resilience and Waste Free Community grants should continue and be an ongoing focus for the department as important spaces where community





conversations occur on the impact of climate change and how waste can be reduced. Finally, the CRP supports SPU's new initiatives and investments related in the Cedar and Tolt watersheds, expanded planning for a sustainable water supply, asset management and waste prevention efforts.

### **Rate Path**

The CRP appreciates SPU's efforts to forgo increases during COVID-19 as Seattleites were dealing with economic and health uncertainties. We are also grateful for the thoughtfulness of SPU staff in bringing forward different rate path options in a time of increasing operational and capital expenses, shifts in inflation and a changing regulatory environment. In addition, interest rates have increased dramatically, and SPU faces a challenging backlog of deferred maintenance needs. The CRP endorses SPU's approach to baseline, critical and smart investments and we agree with how staff have prioritized investments. Finally, the CRP is acutely aware of King County's projected annual 6.5 % wastewater rate increases which have been factored into the SBP overall rate path. Approximately, 56% percent of SPU's wastewater rate goes to pay for King County wastewater treatment. As the CRP described in its letter to Executive Dow Constantine in Spring 2023, "...we continue to be concerned about the anticipated series of larger proposed rate hikes." The CRP renews its call for King County to a) commit to a multi-year rate path; b) engage in more robust, transparent capital project planning, delivery, and staffing; c) participate in thoughtful engagement with impacted stakeholders; d) pursue strategic financing; e) increase its advocacy and prioritization for federal and state dollars; and f) be open to the calls for a new governance model that more appropriately represents Seattle's interests and allows SPU to advocate on behalf of its customers.

Given all of this, the CRP supports an average annual rate path increase of 4.7% with a delay of AMI implementation and a focus on fully funding all critical and smart investments listed in the SPU Strategic Business Plan update.

### **Conclusion**

The CRP appreciates the opportunity to highlight its priorities and perspective. We approached





this SBP update with intentionality, curiosity, passion, and a sense of civic pride to meet our charge to represent Seattle ratepayers. By detailing the CRP priorities in a more organized and thoughtful manner, our panel members hope that tracking and reporting on key investments and initiatives will be streamlined and speak to these priorities. The need for critical investments, affordable rates and innovative programs is clear. By targeting investment in areas of affordability and accessibility, asset management and infrastructure, solidifying its workforce, and funding proactive climate resiliency efforts, SPU can continue to be a leading utility in the nation.

The CRP would like to acknowledge the hard work and dedication of SPU staff in working with our panel members through this process. We appreciate the thoughtful conversations and provision of information that has allowed the CRP to meet its charge. Our panel looks forward to continued partnership, work and collaboration with SPU leading with respect, trust, and common interest in the betterment of Seattle.

Signed,

Noel Miller, Chair  
Retired Public Works Director

Amanda Richer, Vice Chair  
Community Liaison Department of Neighborhood  
City of Seattle

Suzanne Burke  
Business Owner, Fremont

Bobby Coleman  
Administrator, Environmental Stewardship &  
Sustainability, Seattle Housing Authority





A handwritten signature in blue ink that reads "Gretchen Glaub".

Gretchen Glaub  
Salmon Recovery Coordinator,  
Snohomish County

*Ebony Rose Frazier*

Ebony Rose Frasier  
Seattle Resident

A handwritten signature in blue ink that reads "Raj Kumar".

Raj Kumar  
Retired Director, Nestle USA

A handwritten signature in blue ink that reads "Maria McDaniel".

Maria McDaniel  
Senior Business Analyst,  
Information Technology, City of Seattle

A handwritten signature in blue ink that reads "Robin Schwartz".

Robin Schwartz  
Community Member

A handwritten signature in blue ink that reads "Miki Sodos".

Miki Sodos  
Business Owner, Othello & Belltown

CC: Seattle City Councilmembers  
Seattle Public Utilities Director Andrew Lee





## SUMMARY and FISCAL NOTE

<b>Department:</b>	<b>Dept. Contact:</b>	<b>CBO Contact:</b>
Seattle Public Utilities	Paula Laschober	Akshay Iyengar

### 1. BILL SUMMARY

**Legislation Title:** A RESOLUTION relating to Seattle Public Utilities; adopting a 2025–2030 Strategic Business Plan for Seattle Public Utilities; and endorsing a three-year (2025–2027) rate path and a subsequent, three-year (2028–2030) rate forecast to support the Strategic Business Plan Update.

**Summary and background of the Legislation:**

This legislation adopts a six-year Strategic Business Plan (the Plan) for Seattle Public Utilities (SPU) for the years 2025-2030. It also endorses an average annual rate increase of 4.7 percent, across all lines of business, to support the Plan.

In 2012, the Council passed a Statement of Legislative Intent directing Seattle Public Utilities to develop a six-year Strategic Business Plan. A subsequent resolution, Resolution 31429, clarified the primary goal of the Plan, which is to set a transparent and integrated direction for all of SPU’s business lines that reflects customer values, provides customer rate predictability, and results in best value for customer dollars. This resolution also established a nine-member Customer Review Panel to provide input to the Plan during its development and provide to the Mayor and City Council comments on the Plan concurrent with delivery of the final proposed Plan to Council.

The Strategic Business Plan process provides a forum for discussion between SPU, the City Council, and customers. It also provides more transparency and accountability for decision-making within the Utility. This Plan incorporates community and utility feedback as part of the programming and direction for the future of SPU.

The 2025-2030 rate path for water, drainage, wastewater, and solid waste rates is shown below.

	<u>Rate Path</u>			<u>Rate Forecast</u>			<b>Average</b>
	2025	2026	2027	2028	2029	2030	
Water	2.0%	2.0%	6.3%	3.3%	6.5%	3.8%	<b>4.0%</b>
Sewer	5.0%	5.0%	5.0%	6.2%	7.0%	5.1%	<b>5.5%</b>
Drainage	5.0%	5.0%	5.1%	6.6%	6.3%	7.2%	<b>5.9%</b>
Solid Waste	2.5%	3.1%	3.4%	3.4%	3.8%	2.5%	<b>3.1%</b>
<b>Combined</b>	<b>3.7%</b>	<b>3.9%</b>	<b>4.9%</b>	<b>5.0%</b>	<b>6.0%</b>	<b>4.6%</b>	<b>4.7%</b>

\*Note: The combined totals are weighted averages by line of business.

## 2. CAPITAL IMPROVEMENT PROGRAM

Does this legislation create, fund, or amend a CIP Project?  Yes  No

## 3. SUMMARY OF FINANCIAL IMPLICATIONS

Does this legislation have financial impacts to the City?  Yes  No

The legislation adopts a six-year plan and endorses a rate path. Rates for each line of business will continue to be adopted by separate ordinance on a three-year cycle.

### 3.d. Other Impacts

Does the legislation have other financial impacts to The City of Seattle, including direct or indirect, one-time or ongoing costs, that are not included in Sections 3.a through 3.c? If so, please describe these financial impacts.

None

If the legislation has costs, but they can be absorbed within existing operations, please describe how those costs can be absorbed. The description should clearly describe if the absorbed costs are achievable because the department had excess resources within their existing budget or if by absorbing these costs the department is deprioritizing other work that would have used these resources.

N/A

Please describe any financial costs or other impacts of *not* implementing the legislation. SPU would revert to the endorsed 2021-2026 Strategic Business Plan and would continue to have rates adopted for each line of business on a three-year cycle.

## 4. OTHER IMPLICATIONS

a. Please describe how this legislation may affect any departments besides the originating department.

This legislation does not directly affect any other department. Certain projects contained in the Plan are completed in conjunction with other departments, including the Seattle Department of Transportation (SDOT), but coordination is already established and ongoing.

b. Does this legislation affect a piece of property? If yes, please attach a map and explain any impacts on the property. Please attach any Environmental Impact Statements, Determinations of Non-Significance, or other reports generated for this property.

N/A

c. Please describe any perceived implication for the principles of the Race and Social Justice Initiative.



- i. How does this legislation impact vulnerable or historically disadvantaged communities? How did you arrive at this conclusion? In your response, please consider impacts within City government (employees, internal programs) as well as in the broader community.**

This legislation sets forth SPU's three-year adopted rate path and three-year forecasted rates for all its lines of business. SPU's rates impact low-income, vulnerable, and historically disadvantaged households in Seattle. The utility has programs and practices to address rate affordability (through alternative funding pursuit, refinancing, and other efficiencies) and provide financial assistance to low-income customers in addition to conservation measures to reduce billable consumption. SPU's Strategic Business Plan commits the utility to continue to address improvements to low-income financial assistance programs and address utility service access disparities among its customers and communities.

- ii. Please attach any Racial Equity Toolkits or other racial equity analyses in the development and/or assessment of the legislation.**

The impact of rates and service inequities are acknowledged and mapped in the City's racial equity mapping. SPU's Strategic Business Plan sets department-wide goals, strategies, and commitments to ensure it is continuing to address these issues through a variety of techniques including, but not limited to, low-income financial assistance, capital investment prioritization, hiring opportunities, and outreach. Additionally, each of the Plan's highlighted initiatives and investments have assessed RSJ, climate and/or affordability impacts. This information can be found in Appendix A of the Plan.

- iii. What is the Language Access Plan for any communications to the public?**

The Department of Neighborhoods and SPU reached out to 13 disadvantaged communities in the Summer/Fall of 2023 regarding the utility's services and plans. Additionally, SPU ensured that its residential survey conducted in Fall of 2023 was reflective of the community we serve. All materials used were translated into the City's top-tier languages. This information informs SPU's planning and continued commitment to affordability. Concurrent with the Council's adoption process for this plan, SPU will provide public notification of the rate proposal and hearing schedule. We will use ethnic media outlets to ensure that information is available to these populations and provide a translation of the Strategic Business Plan's executive summary. Once adopted, the Strategic Business Plan will also be translated into the top-tier languages.

#### **d. Climate Change Implications**

- i. Emissions: How is this legislation likely to increase or decrease carbon emissions in a material way? Please attach any studies or other materials that were used to inform this response.**

SPU's Strategic Business Plan identifies department goals and high-level commitments to reduce carbon emissions zero waste and circular economy initiatives as well as its overall operations and energy use.

- ii. **Resiliency: Will the action(s) proposed by this legislation increase or decrease Seattle’s resiliency (or ability to adapt) to climate change in a material way? If so, explain. If it is likely to decrease resiliency in a material way, describe what will or could be done to mitigate the effects.**

The Plan identifies high-level commitments to reduce citywide carbon emissions through zero waste and circular economy initiatives. It also identifies department goals to address operational emissions. Commitments include working to address Duwamish Valley water resilience, climate-adaptive water supply planning and watershed resilience investments, and climate informed planning and sizing of operational facility and infrastructure investments.

- e. **If this legislation includes a new initiative or a major programmatic expansion: What are the specific long-term and measurable goal(s) of the program? How will this legislation help achieve the program’s desired goal(s)? What mechanisms will be used to measure progress towards meeting those goals?**

The SPU Strategic Business Plan highlights initiatives and investments described in Appendix A, including their impacts to RSJ, climate, and affordability issues. Progress on these initiatives and investments will be reported on a quarterly basis.

## 5. CHECKLIST

- Is a public hearing required?**
- Is publication of notice with *The Daily Journal of Commerce* and/or *The Seattle Times* required?**
- If this legislation changes spending and/or revenues for a fund, have you reviewed the relevant fund policies and determined that this legislation complies?**  
N/A
- Does this legislation create a non-utility CIP project that involves a shared financial commitment with a non-City partner agency or organization?**

## 6. ATTACHMENTS

### Summary Attachments:

Summary Exhibit A – SPU Financial Summary Report  
Summary Exhibit B – Executive Summary

**Exhibit A**

Strategic Business Plan Rate Path and current SPU Financial Status Report  
March 15<sup>th</sup>, 2024

---

**Executive Summary**

This report highlights the proposed rate path as part of Seattle Public Utilities’ (SPU) proposed 2025-2030 Strategic Business Plan and describes the utility’s financial status as we look to implement the plan. The proposed rate path averages 4.7% over the six-year term. In addition to operations and maintenance, these rates fund capital projects - many of which are required under federal and state regulations - taxes, and other obligations. Overall, there are no substantial changes to the Utility’s operations and capital program.

SPU is in sound financial shape and all of SPU’s funds are financially strong. The proposed rate path meets financial policy goals while preserving rate revenues that can be used to prevent rate volatility and smooth future rates. At the same time, SPU strives to enhance affordability and works to expand several customer programs that offer significant support.

**Strategic Business Plan Rate Path**

Seattle Public Utilities is proposing the new 2025-2030 Strategic Business Plan (SBP) to guide essential service delivery and a comprehensive business strategy for our three lines of business: drinking water, drainage and wastewater, and solid waste. The plan looks forward to the next six years (2025-2030) and provides a predictable three-year rate path to be adopted by City Council and projections for the subsequent three years.

	<b><u>Rate Path</u></b>			<b><u>Rate Forecast</u></b>			
	2025	2026	2027	2028	2029	2030	<b>Average</b>
Water	2.0%	2.0%	6.3%	3.3%	6.5%	3.8%	<b>4.0%</b>
Sewer	5.0%	5.0%	5.0%	6.2%	7.0%	5.1%	<b>5.5%</b>
Drainage	5.0%	5.0%	5.1%	6.6%	6.3%	7.2%	<b>5.9%</b>
Solid Waste	2.5%	3.1%	3.4%	3.4%	3.8%	2.5%	<b>3.1%</b>
<b>Combined</b>	<b>3.7%</b>	<b>3.9%</b>	<b>4.9%</b>	<b>5.0%</b>	<b>6.0%</b>	<b>4.6%</b>	<b>4.7%</b>

The Proposed 2025-2030 Strategic Business Plan calls for a slightly higher six-year rate path compared to the last adopted 2021-2026 Strategic Business Plan. The proposed rate path incorporates higher than anticipated inflation, interest rates, and supply chain costs that have increased to continue utility operations. Overall, the proposed 2025-2030 rate path is an increase from the prior path -- specifically, from 4.2% to an overall annual rate increase of 4.7%, for the average six-year projection, as reflected in the chart below:

### Seattle Public Utilities’ Fiscal Health

SPU is in a good financial position and all of SPU’s funds are financially strong, which means that SPU is in a strong position to support current and emerging needs. The tables below illustrate SPU’s projections of revenues and expenses through 2030. They indicate that SPU will meet or exceed its financial policies through 2030.

#### Financial Policies for All Funds

##### Water Fund

(\$ in millions)	Target	2025	2026	2027	2028	2029	2030
Debt Service Coverage	1.70x	2.0	1.9	1.9	1.8	1.8	1.9
Net Income	>\$0	\$29.4	\$23.2	\$23.8	\$19.7	\$21.5	\$21.7
Cash-to-CIP	>20%	23%	20%	20%	20%	20%	20%
Cash Balance	\$71M (120 days operating cash)	\$110.0	\$110.0	\$110.0	\$110.0	\$104.0	\$107.0
RSF Withdrawals*		\$0.0	\$0.0	\$0.0	\$0.0	\$0.0	\$0.0
Bond Issues		\$106.7	\$107.8	\$108.5	\$109.9	\$112.3	\$106.3
Debt Service		\$78.7	\$81.1	\$84.0	\$86.8	\$94.5	\$90.2

\* Note: RSF is the Rate Stabilization Fund.

##### Drainage and Wastewater Fund

(\$ in millions)	Target	2025	2026	2027	2028	2029	2030
Debt Service Coverage*	1.50x	2.6	2.5	2.4	2.4	2.4	2.4
Net Income	>\$0	\$39.4	\$41.6	\$40.8	\$53.1	\$64.2	\$75.2
Cash-to-CIP	25%	40%	41%	33%	25%	25%	31%
Cash Balance	\$135M (100 days operating cash)	310.0	258.8	216.9	206.4	203.1	179.0
Bond Issues		\$65.7	\$82.5	\$133.3	\$137.8	\$147.2	\$177.0
Debt Service		\$84.8	\$94.2	\$101.8	\$114.1	\$123.7	\$129.8

\*Debt Service Coverage is less taxes.

**Solid Waste  
Fund**

(\$ in millions)	Target	2025	2026	2027	2028	2029	2030
Debt Service Coverage	1.50x	4.1	4.1	4.2	4.3	4.6	4.6
Net Income	>\$0	\$11.3	\$10.1	\$10.9	\$11.3	\$14.0	\$12.6
Cash-to-CIP	Greater of \$4.0M or 10% CIP	100%	100%	100%	100%	100%	100%
Cash Balance	\$29M (45 days operating cash)	\$61.7	\$53.4	\$46.9	\$46.6	\$33.3	\$44.0
RSF Withdrawals*		\$0.0	\$0.0	\$0.0	\$0.0	\$0.0	\$0.0
Debt Service		\$6.0	\$4.0	\$3.5	\$3.2	\$2.4	\$2.4

\* Note: RSF is the Rate Stabilization Fund.

SPU takes a fiscally balanced approach to its financial policies and reserves. By maintaining sufficient reserves, SPU is better able to weather fluctuations in revenues and expenses and navigate financial uncertainty. These prudent practices protect our asset investments and benefit customers through the avoidance of extraordinary rate increases and volatility.

**Cost Containment Efforts and Savings**

The 2021-2026 Strategic Business Plan adopted a six-year rate path of 4.2%. Since that time, SPU has taken steps to reduce short-term and long-term costs. Cost containment and savings efforts help the Utility meet financial policy goals and help preserve rate revenues that can be used to smooth future rates. Examples of recent cost containment efforts and savings include:

- Buy back of higher interest rate debt to save rate payers an estimated \$61M over the next decade.
- Issuance of low interest rate loans for the Ship Canal Water Quality Project, saving rate payers \$99M compared to issuing tax-exempt bonds.
- Prudent fiscal management of each Fund, ensuring maintenance of credit ratings and favorable interest rates.
- Operational reductions in order to offset the costs of new bodies of work. This includes savings from travel and training, professional services, rentals, and temporary employee (TES) savings.
- Capital Program reallocations to absorb increasing project costs as well as new bodies of work.

### Proposed SBP Rate Path Summary

SPU uses a combination of direct rate revenues (bills charged to customers) and revenues from other funding sources to meet SPU’s total revenue requirement, which is the revenue required to cover Operations and Maintenance (O&M) and Capital Improvement Program (CIP) expenses together with any additional revenues required to meet SPU’s financial policy requirements.

Generally, rate increases are the result of covering base inflation and increases in CIP costs (usually due to debt service costs) and may be smaller or greater than the actual change in the rates revenue requirement. This SBP assumes increases in costs due to capital project planning (and associated debt service costs), Operations and Maintenance, as well as costs associated with increases in the Utility Discount Program participation.

As discussed in the previous section, the 2025-2030 SBP includes an average annual combined rate growth of 4.7% per year. The table below summarizes the components of the proposed rate path.

#### The 4.7% Rate Path is Mostly Driven by Inflation and Factors Outside of SPU Control

Color	Category	Description	4.70%
	Financial Policies	SPU adheres to specific financial policies to guide prudent financial decisions (e.g. income required to meet debt service, or using cash in lieu of bond proceeds to pay for a certain amount of CIP).	0.4%
	Other O&M Changes	O&M costs include smart and critical investments in the proposed SBP that exert both upward and downward pressure on rates depending on the year. The larger portion of this cost driver is where SPU estimates inflation exceeds the base rate of 3.1%. Examples include health care and labor.	0.4%
	Taxes	SPU is subject to City and State utility and business taxes.	0.2%
	Major Service Contracts	There are rate impacts driven by changes in the major costs of providing core services including SPU contracts for sewage treatment with King County and service providers for Solid Waste.	0.7%
	Inflation	General inflation in the Seattle area during the period of 2023-2029 is projected to be 3.1%.	3.1%

### Factors Impacting Rates

SPU has been working to flatten rate increases over time. While a consistent growth in rates is expected due to inflationary factors, SPU’s growth in costs to provide services for the 2025-2030 period is projected to be higher than in the 2021-2026 period. Factors impacting the growth in the cost of services include:

- Increased inflation contributing to higher labor and material costs
- Supply chain disruptions
- Higher interest rates

### **Major CIP Projects for Regulatory Compliance**

Each fund is subject to regulatory requirements from the City, State, and/or Federal government including consent decrees. These regulations require the Utility to invest in significant capital improvements to mitigate potentially hazardous contamination of the State’s natural resources. Major CIP projects for compliance include:

- Ship Canal Water Quality Project
- Sewer and Drainage Pipe Rehabilitation
- Historic Landfill Management

Please see Appendix C for additional information on major CIP projects by fund. Also, worth noting, the Water Fund is currently transitioning from a period of regulatory capital improvement to a new phase of asset rehabilitation and seismic improvements. The Water Fund continues to have regulatory capital programs for fish passage and improvements to dam safety.

**Appendix A: Strategic Business Plan Timeline**

Includes Key Dates for Input from the Utility’s Customer Review Panel (CRP)

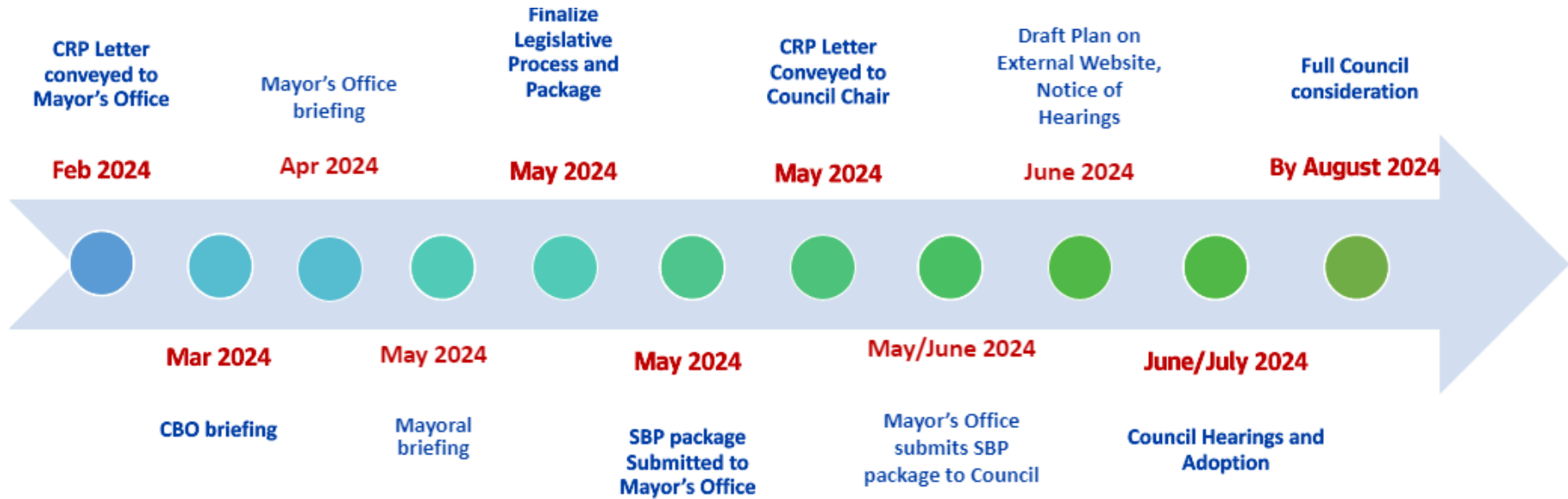



**Appendix B: SPU Customer Assistance**

**SPU Utility Discount Program Facts and Figures**

SPU and Seattle City Light assist more than 36,000 customers through the Utility Discount Program (UDP). We estimate that roughly 40% of eligible customers are enrolled.

In 2023, the UDP provided \$26.6 million in SPU credits to customers. In 2024, the program is anticipated to provide over \$29.8 million in SPU credits. Beginning in 2025, the UDP credits are anticipated to be approximately \$35 million, with growth of \$2.8 million annually (about 2,500 customers per year).

In 2024, the Single-Family utility discount averages \$112.25 per month, while the Multi-Family discount averaging \$64.35.

The following table catalogues all of SPU’s forms of customer assistance.

**SPU Customer Assistance Portfolio**

<b>Program</b>	<b>Benefit</b>	<b>Frequency</b>	<b>Eligibility</b>
Utility Discount Program (UDP)	50% discount (off actual consumption for Single Family Households, and off typical consumption for Multi-Family Households). Single family households receive the discount directly on their bill, and Multi-Family Households see the credit reflected on their SCL account.	Every bill while enrolled in the program.	<ul style="list-style-type: none"> <li>Income at 70% of Washington’s State Median Household Income.</li> </ul>
Emergency Assistance Program (EAP)	Bill credit of up to \$507 in 2024 (\$1,014 for households with children under 18) and split into up to 4 pledges per year.	Once per year (twice per year if household has minor children).	<ul style="list-style-type: none"> <li>Income at 80% of Washington’s State Median Household Income.</li> <li>Single Family Household only.</li> <li>If renting, the SCL bill must be in the tenant’s name.</li> </ul>
UDP Water Shutoff Prevention	Customers enrolled in the UDP program are given an extra week to reach out about emergency assistance before a shutoff.	Ongoing.	Customer must be enrolled in UDP program and be facing a shutoff.

<p>Leak Adjustment Policy</p>	<p>Water and sewer bills are adjusted to address 100% of leak-based charges that occur above normal consumption levels within a designated time frame. (Exception: Commercial sewer bills that have experienced indoor leaks are adjusted by 50%).</p>	<p>One adjustment per calendar year.</p>	<p>Outdoor and indoor leaks.</p>
<p>Payment Plans</p>	<p>Allows flexibility of bill payment timing for current or outstanding debt. Short-term plans require a down payment of 25%, with balance due within 60 days. Long-term plans allow for payment over up to three years with no down payment required.</p>	<p>As needed.</p>	<p>Customers needing flexibility with current or past due bills.</p>

**Appendix C: 2025 – 2030 Major CIP Investments**

Fund	Program Area	Description	Major CIP Projects	2025- 2030 Projection
Drainage and Wastewater	Combined Sewer Overflows	This program consists of projects that are mandated by State and Federal regulations to control combined sewer overflows into the City's receiving waters.	Ship Canal Water Quality Project	\$123M
			Future CSO Projects	\$194M
	Flooding, Sewer Backup, and Landslides	This program prevents and reduces flooding and sewer backups in order to protect public health, safety, and property.	South Park Pump Station, Water Quality Facility, and conveyance improvements	\$75M
			Drainage & Sanitary Sewer Overflow Capacity	\$104M
	Protection of Beneficial Uses	This program improves the drainage system to reduce the harmful effects of stormwater runoff on creeks and receiving water bodies and preserve the storm water conveyance function of our creeks through stream culvert repair and rehabilitation.	Green Stormwater Infrastructure	\$163M
			Creek and Culvert Programs	\$139M
	Rehabilitation	This program repairs, rehabilitates, or replaces existing drainage and wastewater assets to maintain or improve the current functionality level of the system.	Pipe Renewal Program	\$199M
			Pump Station and Force Main Improvements	\$74M
	Sediments	The Sediments program provides funding for studies and analysis for cleanup of contaminated sediment sites in which the City is a participant, for engineering design and construction of actual cleanup of contaminated sites, and for liability allocation negotiations.	Sediment Remediation	\$90M

	Shared Projects	This program includes individual capital projects that benefit multiple Lines of Business (LOB) (e.g. the Water LOB and the Drainage and Wastewater LOB) and for which costs are "shared," or paid for by more than one utility fund.	Transportation-Related Projects	\$80M
			One Water North Operational Facility	\$44M
			<b>Fund Total</b>	\$1,285M
<b>Water Fund</b>	Distribution	This program rehabilitates and improves water mains and appurtenances, water storage tanks, pump stations, and other facilities that are part of the system that distributes treated water.	Watermain Rehabilitation	\$186M
	Transmission	This program rehabilitates and improves large transmission pipelines that bring untreated water to - and convey treated water from - the treatment facilities.	Seismic System Improvements	\$88M
	Water Quality and Treatment	This program constructs, rehabilitates, or improves water treatment facilities, and covers the remaining open water reservoirs.	Bitter Lake Reservoir Covering	\$84M
	Shared Projects	This program includes individual capital projects that benefit multiple Lines of Business (LOB) (e.g. the Water LOB and the Drainage and Wastewater LOB) and for which costs are "shared," or paid for by more than one utility fund.	Transportation-Related Projects	\$42M
One Water North Operational Facility			\$44M	
			<b>Fund Total</b>	\$444M
<b>Solid Waste Fund</b>	New Facilities	This program includes the planning, design, and construction of new facilities to enhance solid waste operations.	South Transfer Station Phase II	\$35M
			Misc. Station Improvements	\$37M
			<b>Fund Total</b>	\$72M
			<b>Major CIP Total</b>	\$1,801M

## 2025-2030 Strategic Business Plan Update EXECUTIVE SUMMARY

### Our Message to You

Every day, Seattle Public Utilities (SPU) delivers essential, life-sustaining water and waste services while protecting public health and our environment to ensure healthy, thriving communities.

In light of the formidable challenges posed by climate change and environmental pollution, SPU is steadfast in its commitment to protect and steward our environmental resources, safeguard and enhance our built infrastructure, and invest in our communities—particularly in those that are highly vulnerable. As we face a changing world, we remain dedicated to delivering life-sustaining services and managing our infrastructure for you.

### Why We’re Updating Our Plan

SPU’s Strategic Business Plan (SBP) helps us focus our work. It builds on our strengths and guides our essential service delivery and comprehensive business strategy. It also provides our customers with a predictable three-year rate path and projections for the subsequent three years.

While each SBP covers six years, we update it after three years to allow for future uncertainties and adjustments. This update reinforces SPU commitments, reflects on our progress over the last three years, responds to factors influencing our work, and informs our rate path.

#### Our Mission

Seattle Public Utilities fosters healthy people, environment, and economies by partnering with our community to equitably manage water and waste resources for today and for future generations.

#### Our Vision

Community Centered, One Water, Zero Waste

#### Our Guiding CARES Principles

**Customers and Community**  
**Affordability and Accountability**  
**Risk and Resilience**  
**Equity and Empowerment**  
**Service and Safety**

## Our Focus Areas and Goals

### Focus On: Delivering Equitable Essential Services

<p><b>Goals</b></p> <ul style="list-style-type: none"> <li>• Provide reliable, quality services that meet requirements and commitments.</li> <li>• Make equitable investments to improve services for underserved and over-burdened communities.</li> </ul>	<p><b>Highlighted Initiatives and Investments</b></p> <ul style="list-style-type: none"> <li>• North “One Water” Operations Facility</li> <li>• In-House Water Quality Treatment</li> <li>• Field Engineering Improvements Program</li> <li>• SPU Support Services for the Unsheltered</li> <li>• Duwamish Valley Resilience</li> </ul>
<p><b>Strategies</b></p> <ul style="list-style-type: none"> <li>• Provide resources and facilities and remove barriers to ensure frontline service delivery staff can be successful.</li> <li>• Prioritize and support equitable access to essential services.</li> </ul>	

### Focus On: Stewarding Environment and Health

<p><b>Goals</b></p> <ul style="list-style-type: none"> <li>• Develop One Water resilience from our watersheds, to cities, to the Sound.</li> <li>• Advance the zero waste circular economy.</li> </ul>	<p><b>Highlighted Initiatives and Investments</b></p> <ul style="list-style-type: none"> <li>• Shape Our Water—Citywide and Focus Area Drainage and Wastewater Planning</li> <li>• Water Supply Planning for the Next 50 Years</li> <li>• Cedar and Tolt Watershed Resilience</li> <li>• Upstream Legislative Strategies to Reduce Pollution and Waste</li> <li>• 2030 Carbon Neutrality and Sustainable Operations</li> <li>• Waste Prevention and Diversion</li> </ul>
<p><b>Strategies</b></p> <ul style="list-style-type: none"> <li>• Invest in strategic plans, projects, and programs that advance a holistic One Water approach.</li> <li>• Advance nature-based and community-centered climate adaptations and solutions.</li> <li>• Reduce materials use and prevent water and carbon pollution.</li> </ul>	

## Focus On: Empowering Our Customers, Community, and Employees

### Goals

- Build trusted relationships, partnerships, and allyships with our customers and communities.
- Be an anchor institution that advances equity, addresses environmental justice, and partners to leverage holistic community benefits in all that we do.
- Invest in all our employees.

### Strategies

- Provide utility assistance that makes a difference.
- Empower and support customers to make sustainable behavioral changes.
- Lead with race and social justice in delivering equitable engagement, capacity building, investment outcomes, and opportunities.
- Foster a more equitable workplace, work culture, and better work opportunities.

### Highlighted Initiatives and Investments

- Customer Affordability Programs
- Side Sewer Assistance Program
- Advanced Metering Infrastructure Planning
- Seeds of Resilience Impact Investment Fund
- Equity in Contracting
- Employee Life Cycle Initiatives

## Focus On: Strengthening Our Utility’s Business Practices

### Goals

- Enhance ratepayer affordability and utility accountability.
- Manage assets and risks optimally.
- Foster a culture of shared leadership, continuous improvement, and innovation.

### Strategies

- Deliver on high-impact affordability and accountability commitments.
- Address aging, undersized, and at-risk facilities and infrastructure to ensure continuous service delivery.
- Support a culture of continuous improvement and innovation.

### Highlighted Initiatives and Investments

- Alternative Funding and Financing
- Drainage and Wastewater Asset Management Program
- Water Asset Management and Seismic Program
- Strategic Technology Plan

## Rate Path

As a responsible steward of ratepayer dollars, SPU diligently works to reduce costs, increase productivity and efficiency, invest in assets that have multiple benefits, and remove barriers to service access. This includes leveraging alternative sources of funding and financing, identifying efficiencies in capital project delivery, and managing infrastructure assets in a way that balances short- and long-term risk with cost and public benefit.

### Factors Impacting Rates

SPU develops rates by evaluating operating costs, capital investment needs, long-term risks, debt repayment, service demands, financial policies, and anticipated revenue associated with service delivery.

We limit the increase in the cost of services by:

- replacing aged infrastructure to avoid costly failures,
- implementing continuous improvement and innovation initiatives to reduce waste,
- automating processes and introducing new technology to increase efficiencies,
- improving capital infrastructure planning to better reflect probable investments,
- using cash balances to smooth rate changes,
- negotiating lower contract rates, and
- reducing the cost of borrowing money.

However, several factors can increase costs and offsetting savings. These include inflation, regulatory compliance, aging infrastructure, increased interest rates, and increasing contractual obligations.

### Three-year Rate Path and Projection

SPU’s six-year rate path is updated every three years. The projected average annual rate increase for 2025-2030 is 4.7 percent, up from 4.2 percent in 2021-2026.

**Table 1: 2025-2030 Average Rate Increases**

	<u>Rate Path</u>			<u>Rate Forecast</u>			<b>Average</b>
	2025	2026	2027	2028	2029	2030	
Water	2.0%	2.0%	6.3%	3.3%	6.5%	3.8%	<b>4.0%</b>
Wastewater	5.0%	5.0%	5.0%	6.2%	7.0%	5.1%	<b>5.5%</b>
Drainage	5.0%	5.0%	5.1%	6.6%	6.3%	7.2%	<b>5.9%</b>
Solid Waste	2.5%	3.1%	3.4%	3.4%	3.8%	2.5%	<b>3.1%</b>
<b>Combined</b>	<b>3.7%</b>	<b>3.9%</b>	<b>4.9%</b>	<b>5.0%</b>	<b>6.0%</b>	<b>4.6%</b>	<b>4.7%</b>

The rise in the average annual rate increase is based on several factors:



- Higher than expected increases in King County wastewater treatment charges to Seattle;
- Increasing operational expenses due to inflation; and
- Increasing capital expenses related to state and federal regulatory compliance, aging infrastructure, and increased interest rates.

## Bill Impact

SPU recognizes the impact of rate increases on our customers and communities. We take affordability seriously and work hard to minimize the impact by keeping increases as low as possible, ensuring rates are predictable, and providing financial assistance for those who need it.

Table 2 shows typical monthly costs for a single family home customer (SPU bills are bi-monthly).

	<b>2025</b>	<b>2026</b>	<b>2027</b>	<b>2028</b>	<b>2029</b>	<b>2030</b>
Water	\$50	\$51	\$54	\$56	\$60	\$62
Sewer	\$83	\$87	\$92	\$97	\$104	\$109
Drainage*	\$63	\$66	\$69	\$74	\$78	\$84
Solid Waste	\$60	\$62	\$64	\$66	\$68	\$70
<b>Combined</b>	<b>\$256</b>	<b>\$266</b>	<b>\$279</b>	<b>\$293</b>	<b>\$310</b>	<b>\$325</b>
<b>Monthly Change</b>	<b>\$11</b>	<b>\$10</b>	<b>\$13</b>	<b>\$14</b>	<b>\$17</b>	<b>\$15</b>

\* Drainage charges are billed to customers on their King County property tax statements.

## Customer Financial Assistance

Our customers should have access to essential services regardless of their financial situation. This is why our affordability and accountability commitments are so important. Through this work, we aim to keep rate increases as low as possible and reduce potential hardship for our customers. We also offer bill assistance and programs to help customers save money, including:

- **Conservation and education programs** that help customers understand how their usage affects their bills and identify ways to potentially reduce them;
- The **Utility Discount Program**, which provides ongoing bill assistance to income-qualified customers;
- The **Emergency Assistance Program**, which provides credits to reduce past-due balances for income-qualified customers facing financial hardship;
- **Payment plans** that provide customers with flexibility in payments timed to fit their needs; and
- SPU’s **Community Donation Fund**, which allows for voluntary contributions to help those in need.

[Learn More](#)

The full 2025-2030 Strategic Business Plan Update can be found at <https://www.seattle.gov/utilities/about/plans/strategic-business-plan>.

# Ship Canal Water Quality Project

Parks, Public Utilities & Technology Committee

*Budget Update – June 26, 2024*

# Agenda

1. Project and Budget Overview
2. Cost and Schedule Factors
3. Budget Details
4. Next Steps and Summary

**Ship Canal**  
WATER QUALITY PROJECT



**Seattle  
Public  
Utilities**



**King County**

- Reducing Seattle's combined sewer overflows
- Joint Project with King County
- Construction underway

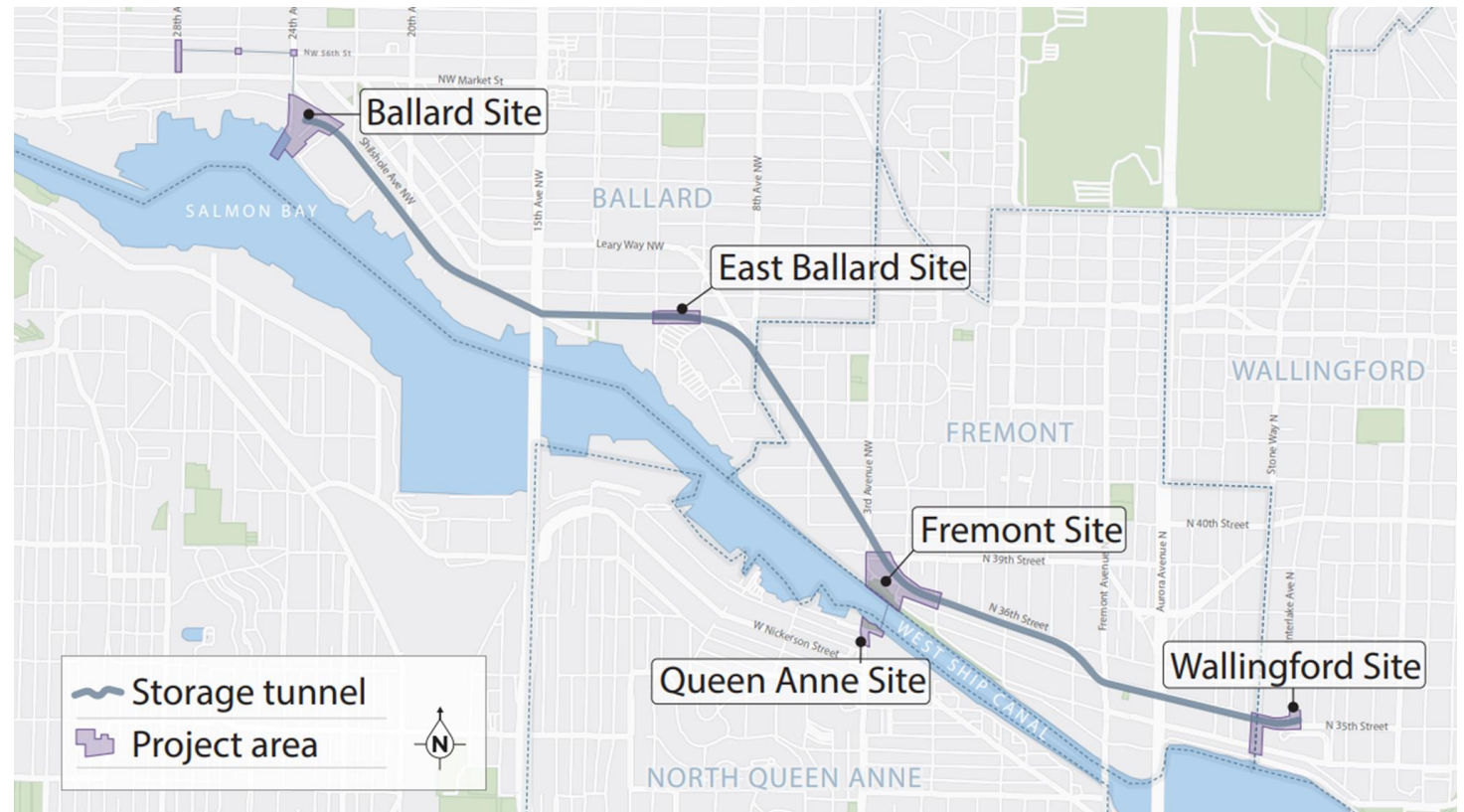

# 2013 Wastewater Consent Decree

- With US Department of Justice, US Environmental Protection Agency, and WA Department of Ecology
- Performance requirement:  
*Less than 1 overflow per outfall per year on a 20-year moving average*

## **SPU investments to reduce CSOs since 2008:**

- 4 major tank projects
- 2 major green stormwater projects
- 50 sewer system improvement projects

Plus the Ship Canal Water Quality Project and several green stormwater projects are under construction.

# Progress to Date

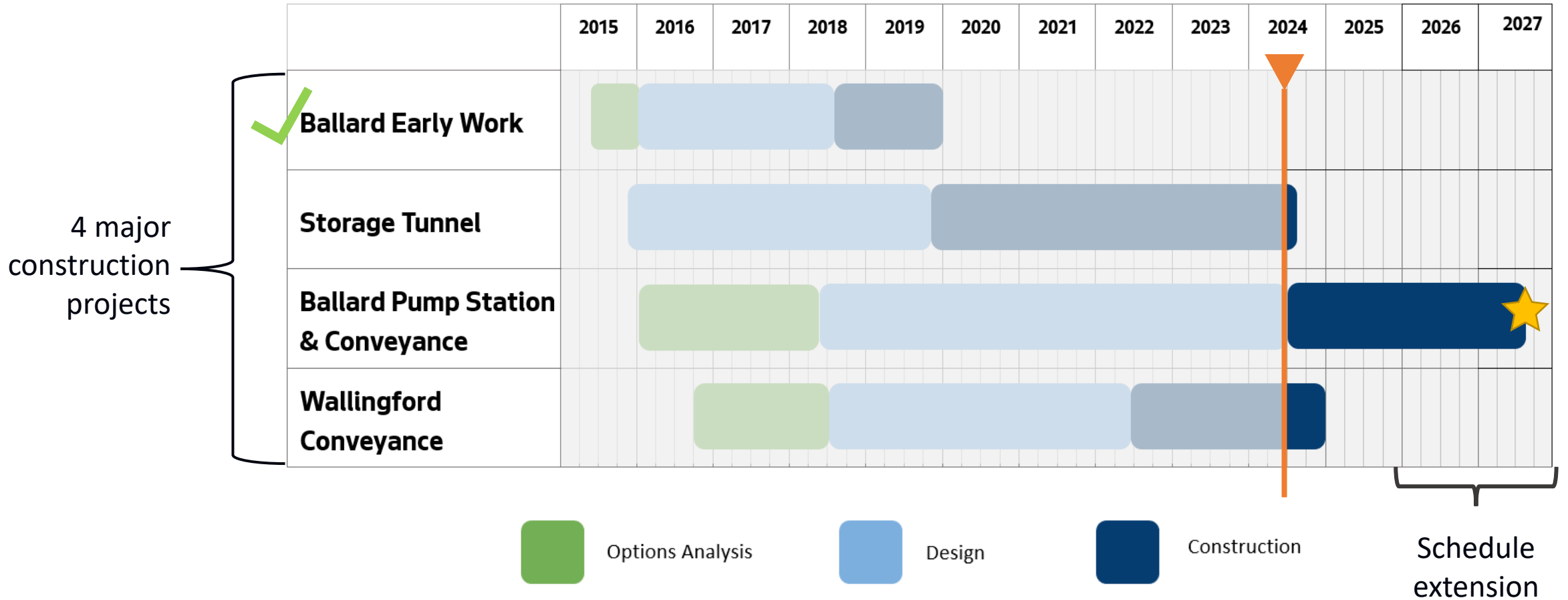

## Ballard Early Work

- Constructed permanent pier, power for tunneling, removed contaminated soil
- Total Project Cost: \$10M
- Completed in 2019



## Wallingford Conveyance

- Construction since 2023 of new conveyance pipes
- Total Project Cost Projection: \$19M
- **Will be completed this year**



## Storage Tunnel

- Construction since 2020 in 5 neighborhoods plus storage tunnel
- Total Cost Projection: \$335M
- **Will be completed this year**

# Ballard Conveyance and Pump Station

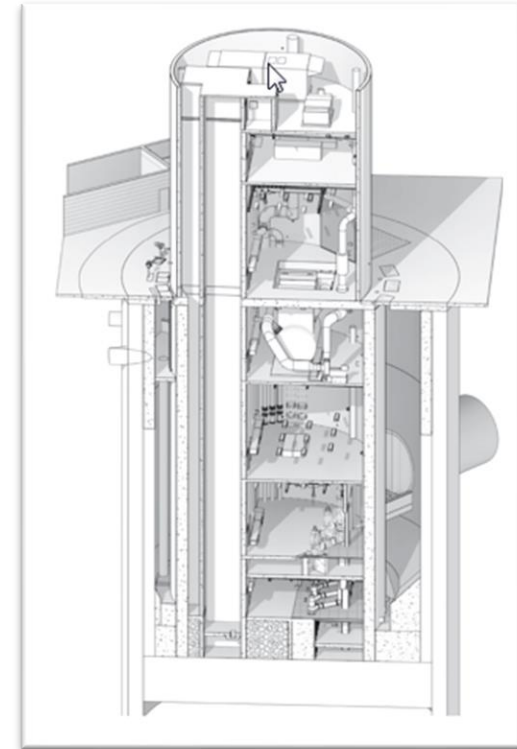
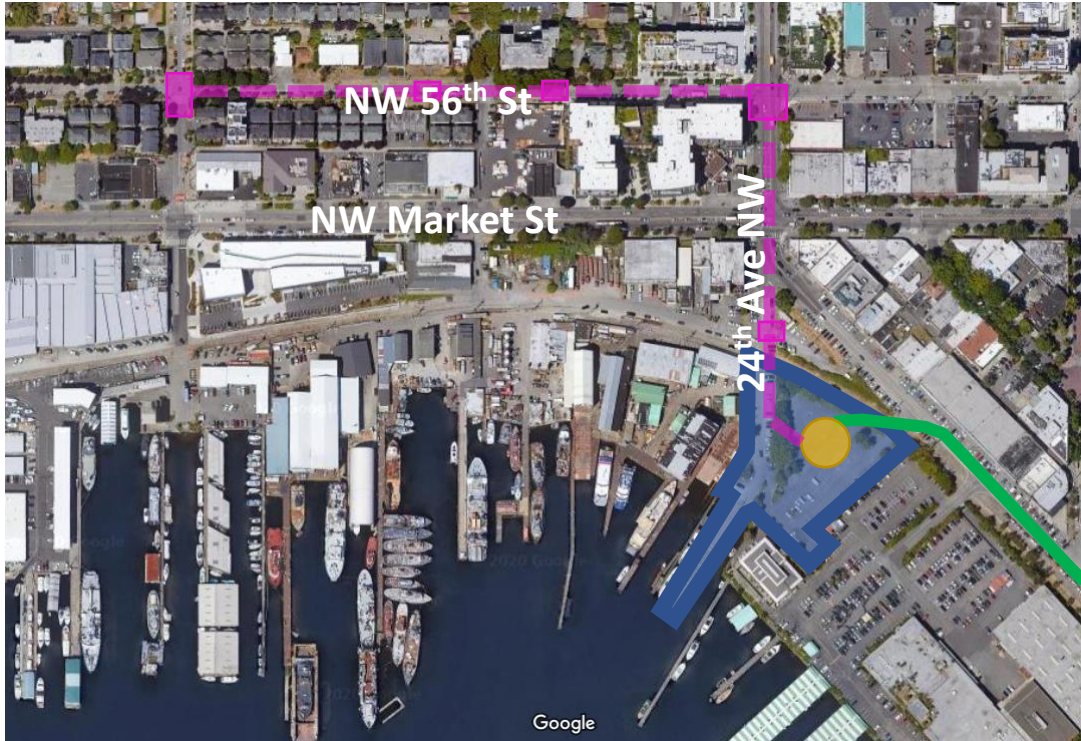



# 2024 Cost Estimate - Key Factors



## Escalation

What will labor and materials cost in the future?



## Risks

What construction issues will impact costs and schedule?

# Best Practices: Escalation Estimates, Risk & Cost Management

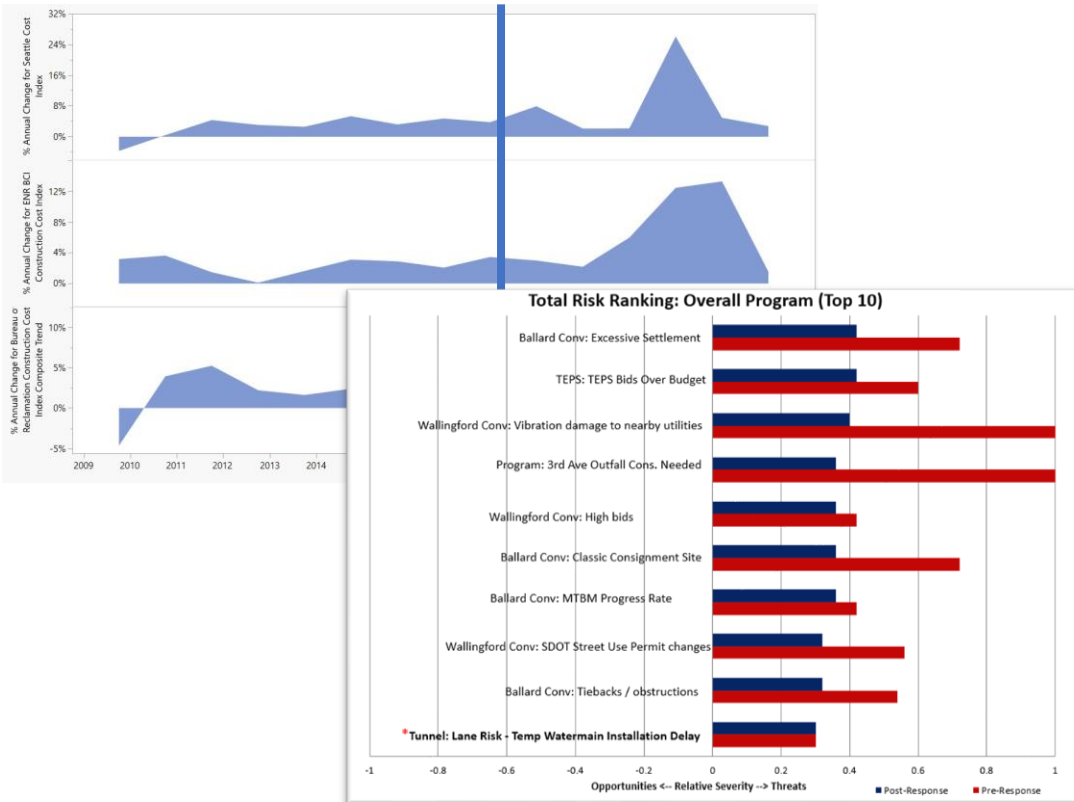

## Cost Management

1. Monthly reviews:
  - scope, schedules, and costs
  - risk registers and evaluation of budget confidence
2. Value engineering
3. Project cost reviews
4. Financing options

# Budget - Key Factors since 2018

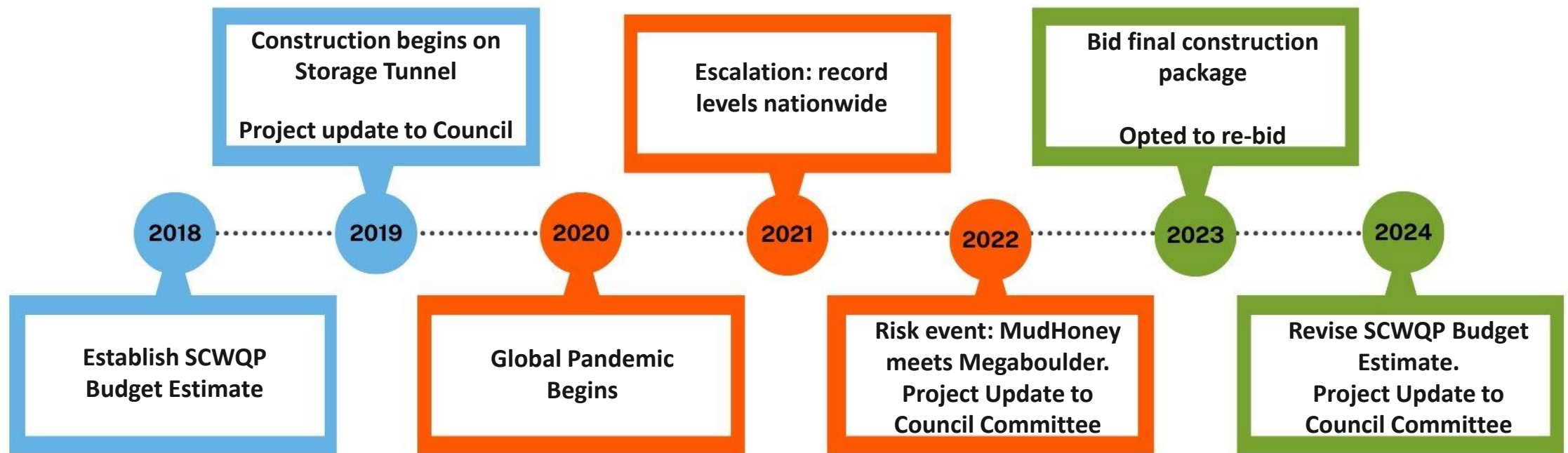

# Impact: Cumulative Escalation

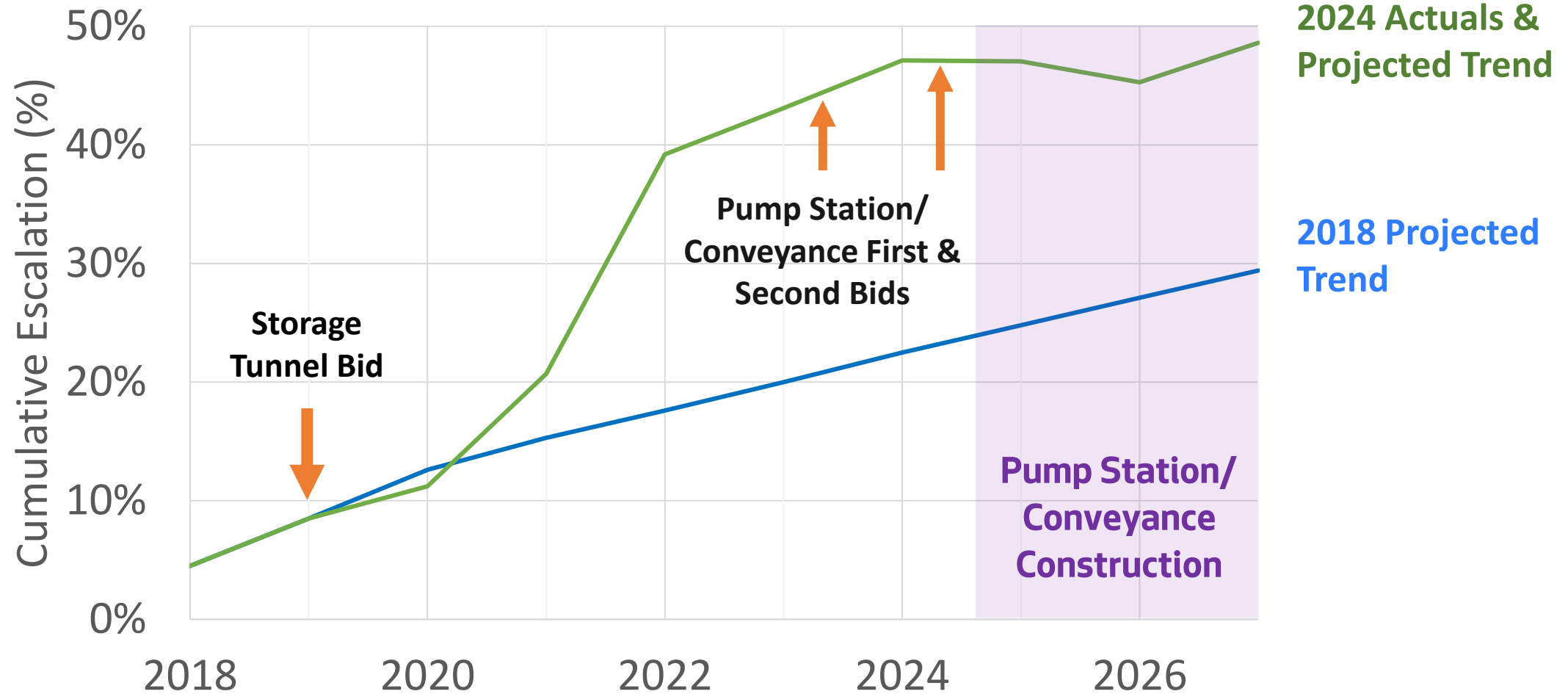

# Impact: Underground Risk Events

## A 12-foot diameter mega-boulder

- Risk register covered at 5% likelihood
- Contractor asserted damages of ~3.5 months, \$17M

## Inaccurate “As-built” records

- Underground infrastructure not per as-builts
- \$1.8M impact

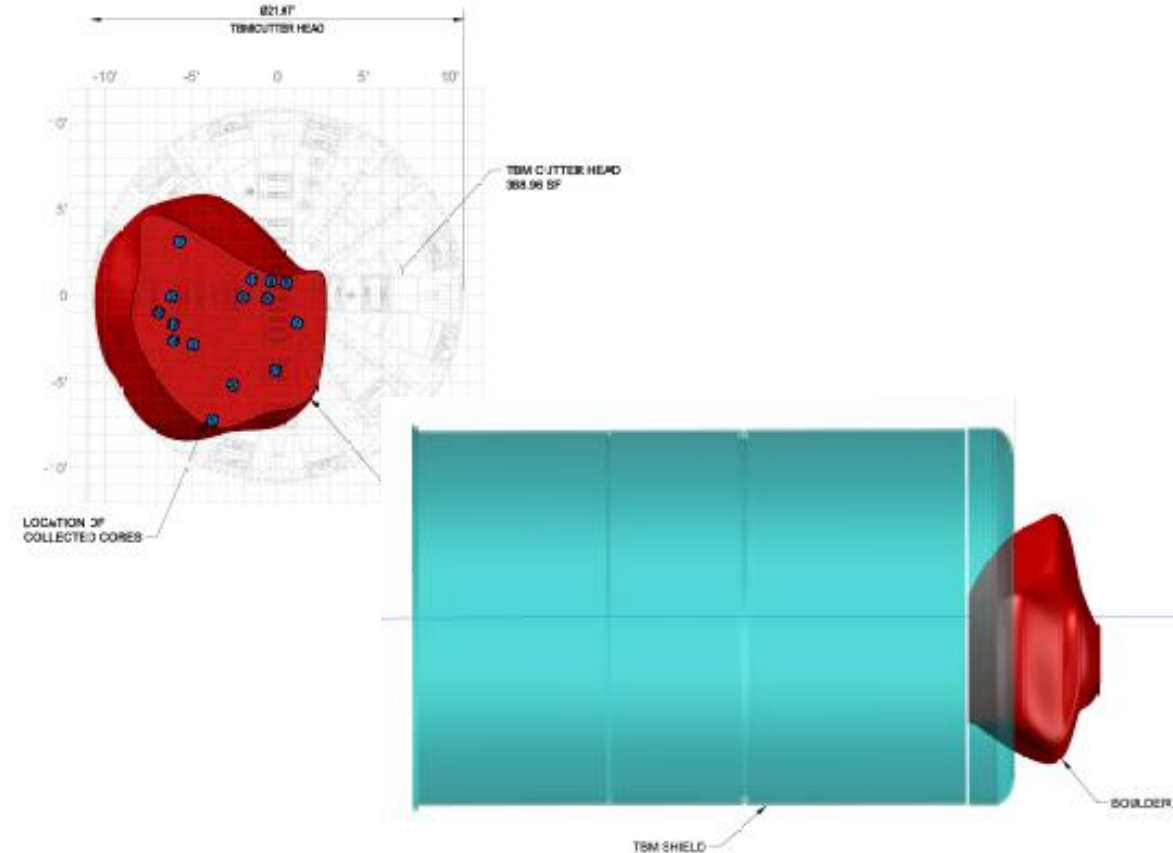

# Cost Management

SCWQP Action	Savings
3 major value engineering and cost reduction efforts	\$67M cost reductions
Over \$341M in 3 low interest rates loans	\$267M over the life of the loans
Restructured and re-bid the Ballard Pump Station and Conveyance Construction Package	\$22M cost reduction

# 2024 Project Budget

**\$710 M**  
**80% confidence**

*SPU is committed to managing capital project budgets within the Strategic Business Plan rate path with no impact to the City's General Fund.*

# Budget Variance - \$570M to \$710M

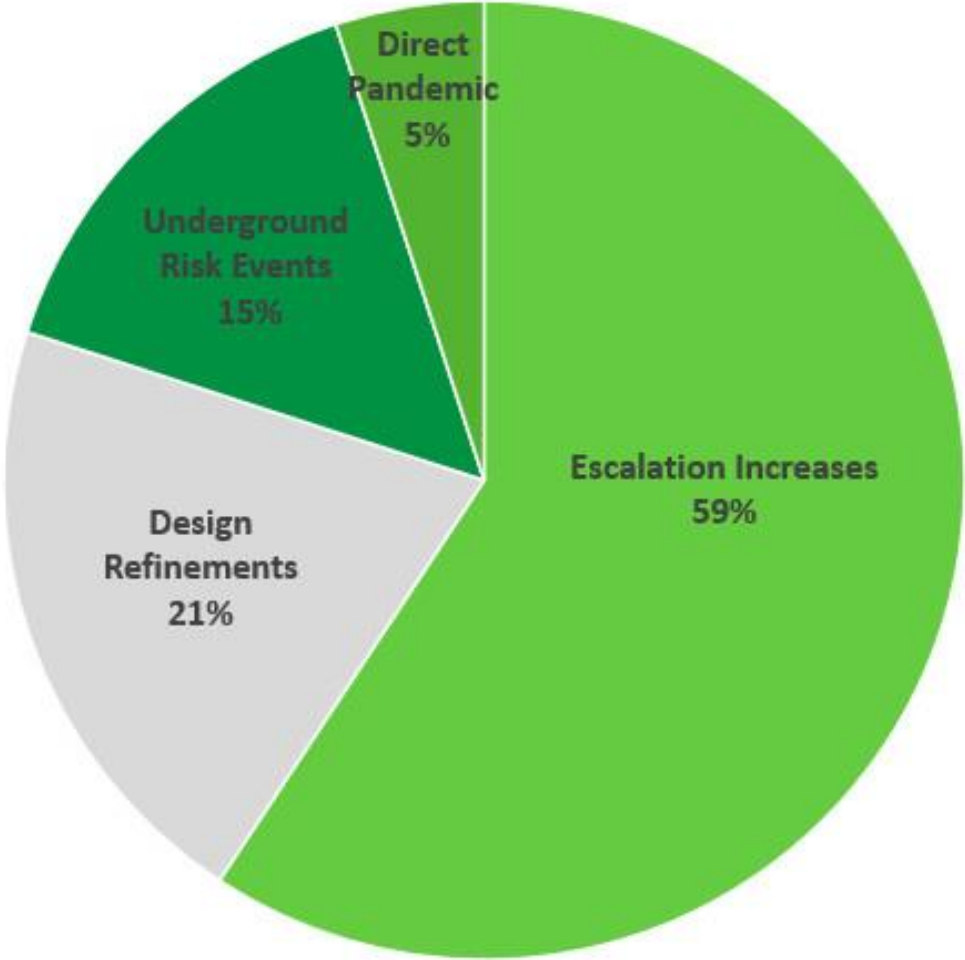

Design Refinements Category:

- Design Refinements
- Scope Addition/Change
- Planning Estimate Corrections





# Summary

- 2024 Project Budget: \$710M at 80% confidence
- Project Completion: 2027
- Project costs will be managed within the Strategic Business Plan rate path

