



# ALLEY VACATION PROPOSAL SPRING STREET TOWERS

Lennar Multifamily Communities

SEATTLE, WA / MARCH 6, 2018

# CONTENTS

01 / Background

02 / Alley Vacation

03 / Public Benefits

# NEIGHBORHOOD CONTEXT



SENECA ST

SITE

SPRING ST

8TH AVE

7TH AVE

MADISON ST

# FIRST HILL NEIGHBORHOOD

- 1 Washington Athletic Club
- 2 Eagles Temple Building
- 3 Town Hall
- 4 YMCA Club
- 5 Women's University Club
- 6 Stimson / Green House
- 7 Dearborn House
- 8 Baroness Apartment Hotel
- 9 Sorrento Hotel
- 10 St. James Cathedral
- 11 First United Methodist
- 12 Rainer Club
- 13 Virginia Mason Campus
- 14 Swedish Medical Campus

-  Site
-  Alley

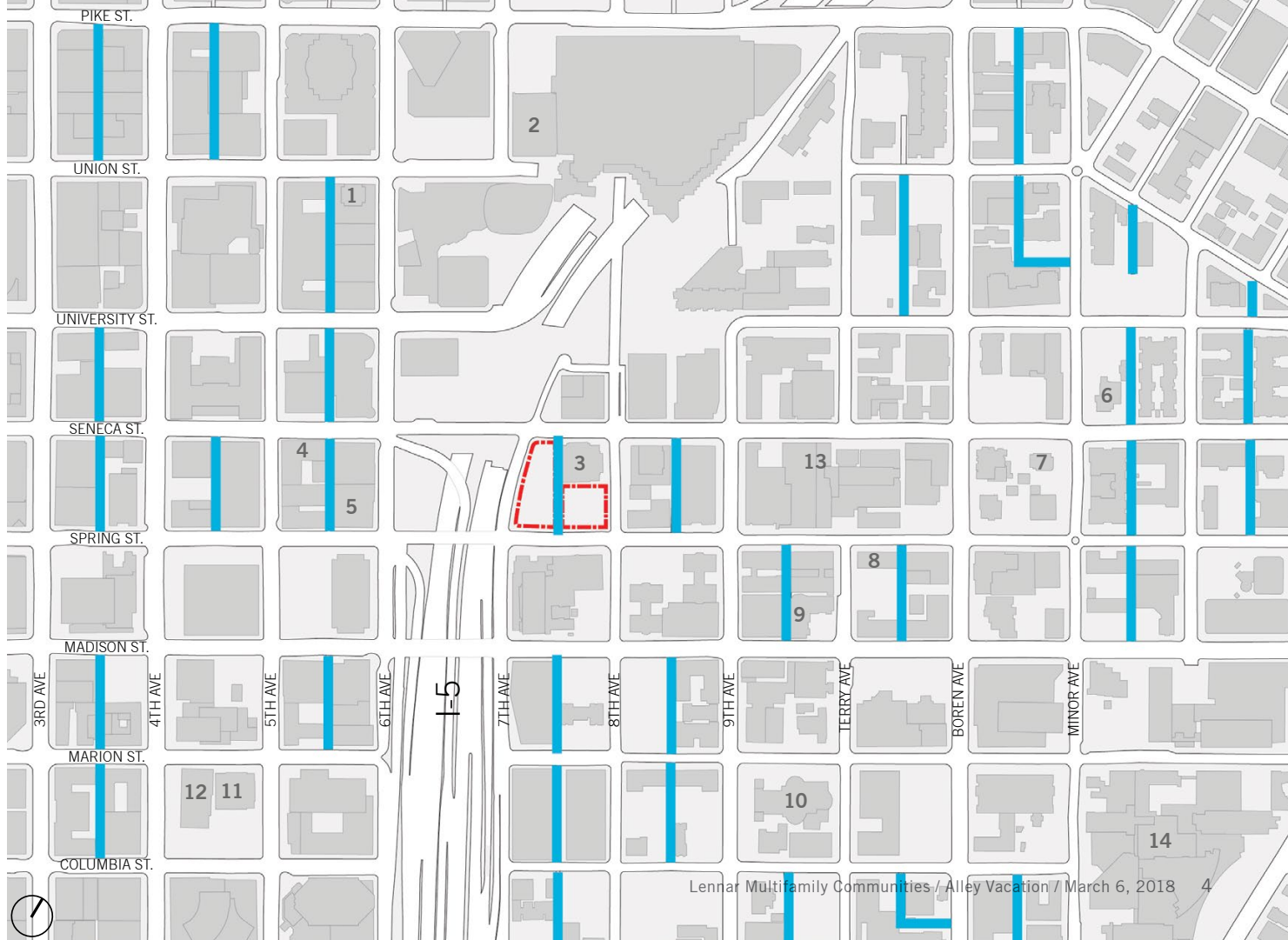

# PUBLIC OUTREACH

## Town Hall Seattle

November 16, 2015  
September 8, 2016  
September 21, 2016  
June 23, 2017

## First Hill Improvement Association

August 3, 2016  
September 13, 2016  
February 10, 2017  
April 4, 2017

## Freeway Park Association

January 29, 2016  
February 14, 2017  
June 15, 2017  
January 5, 2018

## Seattle Design Commission

March 2, 2017  
May 4, 2017  
July 6, 2017

## Design Review Board

October 19, 2016  
May 31, 2017



# NO VACATION / VACATION MASSING

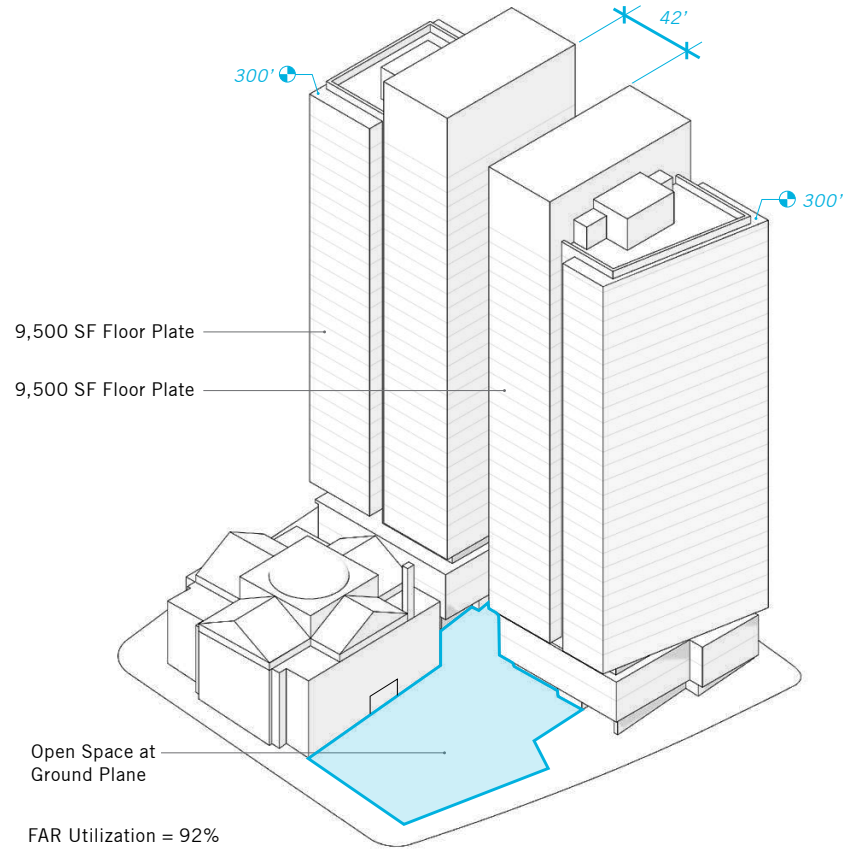
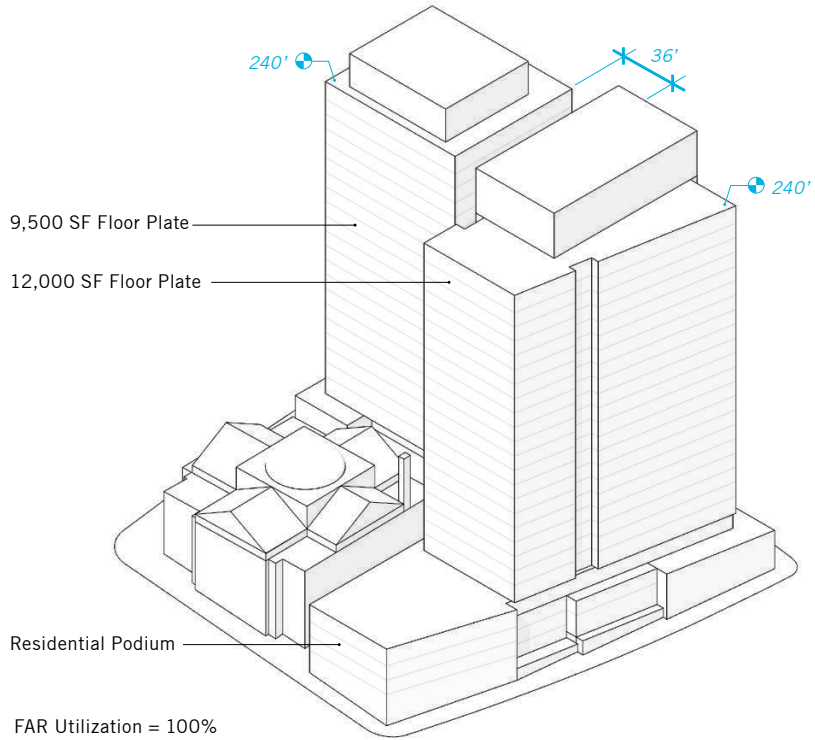

# ALLEY VACATION PROPOSAL SUMMARY

## Project:

- Two residential towers (548 units)
- Eight levels of below grade parking
- Ground level retail
- Restaurant with mezzanine
- Dining terrace and ground level open space amenities
- Residential amenities at base and rooftop
- Outdoor rooftop pool
- Public plaza

## Alley Vacation (3,842 sf):

- enables efficient parking below grade
- allows the two towers to function as a single building
- creates a better pedestrian experience
- limits vehicle access to a single point along Hubbell
- creates an outdoor open space for community gathering
- contributes to Town Hall



# PUBLIC BENEFIT SUMMARY

## 01 - Public Plaza



## 02 - Town Hall Improvements



## 03 - ROW Improvements



## 04 - Freeway Park Connection











# LANDSCAPE PLAN

- 1 Town Hall
- 2 Plaza
- 3 Woonerf
- 4 Pedestrian Mews
- 5 Dining Terrace
- 6 Restaurant
- 7 Retail
- 8 Office
- 9 Residential Lobbies
- 10 Residential Units
- 11 Parking Entry
- 12 Water Feature
- 13 Freeway Park Connection



# SITE ACCESS

-  Pedestrian Entries
-  Parking + Service Entry
-  Drop-off / Deliveries
-  Accessible Public Route
-  Public Elevator
-  Bike Racks
-  Transit Stop

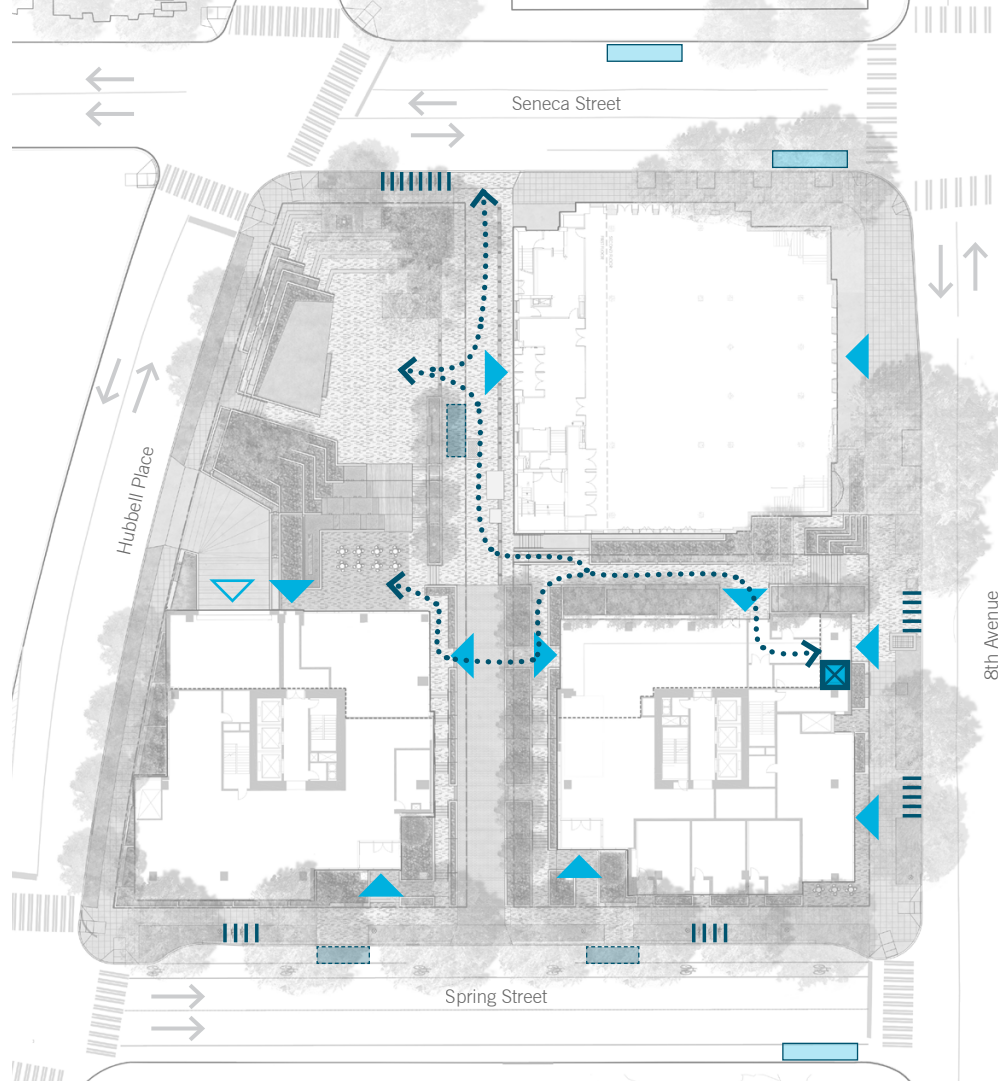

# PUBLIC BENEFITS PLAZA FROM SENECA



**PUBLIC BENEFITS**  
**SPRING ST AND 8TH AVE**



**PUBLIC BENEFITS**  
**SPRING STREET**



# PUBLIC BENEFIT SUMMARY

PUBLIC BENEFIT	DESCRIPTION				APPROX. VALUE	CODE REQ'D
1 - Public Plaza	<b>5,500 SF Public Plaza Open Space, includes:</b> 2,500 SF special paving (\$250,000) 1,015 SF terraced planting (\$255,000) 2 existing trees preserved (\$5,000) 3 new trees (\$9,000) 845 SF seating lawn (\$50,000) 25 LF wood benches (\$2,000) 200 SF wood platform (\$10,000) Lighting - tree lights, pedestrian poles, bollard lights, bench lights, handrail lights (\$110,000)				\$4,800,000	None
2 - Town Hall Improvements	<b>Contribution for 3,000 SF of sidewalk improvements along Seneca Street + 8th Avenue</b>				\$ 50,000	None
	<b>1,140 SF of new landscaping at south side of site</b>				\$ 97,000	
	<b>3,000 SF of Woonerf, includes special paving + bollards</b>				\$204,000	
3 - ROW Improvements	<b>Hubbell Place</b> 30 LF of underlit seating pedestrian lights	<b>Seneca Street</b> 100 SF of special paving 6 bike racks	<b>Spring Street</b> 145 SF of planting 217 SF of special paving 15 LF of underlit seating 5 bike racks pedestrian lights	<b>8th Avenue</b> 320 SF of planting 500 SF of special paving 16 LF of underlit seating 8 bike racks pedestrian lights	\$135,000	None
4 - Freeway Park Connection	<b>Design contribution to intersection improvements</b>				\$ 25,000	None
	<b>Accessible curb ramp at northwest corner of Seneca and Hubbell</b>				\$ 10,000	
<b>Total Value</b>					<b>\$5,321,000</b>	

