

CHAPTER 1

ADMINISTRATION

Note: Chapter 1 is entirely Seattle amendments to the *International Mechanical Code* and is not underlined.

SECTION 101 TITLE

101.1 Title. These regulations shall be known as the “Seattle Mechanical Code,” may be cited as such, and are referred to herein as “this code.” All references to the *International Mechanical Code* contained in this code mean the *Seattle Mechanical Code*.

SECTION 102 PURPOSE

102.1 Purpose. The purpose of this code is to provide minimum standards to safeguard life or limb, health, property and public welfare by regulating and controlling the design, construction, installation, quality of materials, location, operation, and maintenance or use of heating, ventilating, cooling, refrigeration systems, incinerators and other miscellaneous heat-producing appliances within the City. The purpose of this code is to provide for and promote the health, safety and welfare of the general public, and not to create or otherwise establish or designate any particular class or group of *persons* who will or should be especially protected or benefited by the terms of this code.

SECTION 103 APPLICABILITY AND SCOPE

103.1 Scope. This code applies to the erection, installation, *alteration*, repair, relocation, replacement, addition to, use or maintenance of any heating, ventilating, cooling, refrigeration systems, incinerators or other miscellaneous heat-producing appliances within the City. The design and testing of *equipment* regulated by this code are subject to the approval of the code official. The installation of fuel gas distribution piping and equipment, fuel gas-fired appliances and fuel gas-fired appliance venting systems shall be regulated by the International Fuel Gas Code. References in this code to Group R shall include Group I-1, Condition 2 assisted living facilities licensed by Washington state under chapter 388-78A WAC and Group I-1, Condition 2 residential treatment facilities licensed by Washington state under chapter 246-337 WAC.

Exceptions:

1. Detached one- and two-family dwellings and multiple single-family dwellings (*townhouse units*) not more than three stories above grade plane with a separate means of egress and their accessory structures shall comply with the *International Residential Code*.
2. The standards for liquefied petroleum gas installations are the 2017 edition of NFPA 58 (Liquefied Petroleum Gas Code) and the 2018 edition of ANSI Z223.1/NFPA 54 (National Fuel Gas Code), as amended.

103.2 Applicability of city laws. A mechanical permit application shall be considered under the Seattle Mechanical, Fuel Gas and Energy codes in effect on a date as provided below, or on a date as otherwise required by law.

1. Mechanical permit applications shall be considered under the codes in effect on the date used to determine the codes applicable to the building permit application according to Seattle Building Code Section 101.3 if any of Items 1.1 through 1.3 apply:
 - 1.1. The mechanical permit application is submitted as part of a building permit application;
 - 1.2. The mechanical permit application is for work directly associated with a building permit but is submitted separately from the building permit application; or
 - 1.3. The mechanical permit application is for initial tenant *alterations* submitted no later than 18 months after the date of the *approved* final inspection for the building, and is submitted before the expiration date of the building permit for the tenant *alteration*, as determined by *Seattle Building Code* Section 106.9.
2. Mechanical permit applications other than those subject to Item 1 shall be considered under the codes in effect on the date a complete mechanical permit application is submitted that complies with all the requirements of Section 116.

103.3 Additions, alterations and repairs. Additions, *alterations*, repairs and replacement of *equipment* or systems shall comply with the provisions for new *equipment* and systems except as otherwise provided in Section 104 of this code.

SCOPE AND ADMINISTRATION

Exception: Additions, *alterations*, renovations or repairs to a mechanical system that is part of a building addition with less than 500 square feet of conditioned floor area are exempt from the requirements for *whole house ventilation systems*, Section 403.4.4.

103.4 Internal consistency. If in any specific case, different sections of this code specify different materials, methods of construction or other requirements, the most restrictive governs. If there is a conflict between a general requirement and a specific requirement, the specific requirement governs.

103.5 Referenced codes and standards. The codes and standards referenced in this code are part of the requirements of this code to the extent prescribed by each such reference. If differences occur between provisions of this code and referenced codes and standards, the provisions of this code apply.

Exception: Where enforcement of a code provision would violate the conditions of the listing of the *equipment* or appliance, the conditions of the listing and manufacturer’s instructions apply.

103.6 Appendices. Provisions in the *International Mechanical Code* appendices do not apply unless specifically adopted.

103.7 Metric units. Wherever in this code there is a conflict between metric units of measurement and U.S. customary units, the U.S. customary units govern.

103.8 References to other codes. Whenever an International, National or Uniform Code is referenced in this code, it means the Seattle edition of that code, including local amendments. References to the “Building Code”, “Fuel Gas Code”, “Fire Code”, “Residential Code” and “Plumbing Code” mean the Seattle editions of those codes.

SECTION 104 APPLICATION TO EXISTING MECHANICAL SYSTEMS

104.1 Additions, alterations, renovations or repairs. Additions, *alterations*, renovations or repairs may be made to any mechanical system without requiring the existing mechanical system to comply with all the requirements of this code, if the addition, *alteration*, renovation or repair conforms to the standards required for a new mechanical system. Additions, *alterations*, renovations or repairs shall not cause an existing system to become *unsafe*, unhealthy or overloaded.

Minor additions, *alterations*, renovations, and repairs to existing mechanical systems may be installed in accordance with the law in effect at the time the original installation was made, if *approved* by the code official.

104.2 Existing installations. Mechanical systems lawful at the time of the adoption of this code may continue their use, be maintained or repaired, be converted to another type of fuel, or have components replaced if the use, maintenance, repair, conversion of fuel, or component replacement is done in accordance with the basic original design and location, and no hazard to life, health or property has been or is created by such mechanical system.

104.3 Changes in building occupancy. Mechanical systems that are a part of a building or structure undergoing a change in *occupancy* as defined in the *International Building Code* shall comply with all requirements of this code that are applicable to the new use or *occupancy*.

104.4 Maintenance. All mechanical systems, materials, *equipment*, appurtenances and all parts thereof shall be maintained in proper operating condition in accordance with the original design and in a safe and hazard-free condition. All devices or safeguards that were required by a code in effect when the mechanical system was installed shall be maintained in conformance with the code edition under which installed. The owner or the owner’s authorized agent is responsible for maintenance of mechanical systems and *equipment*. To determine compliance with this subsection, the code official may cause a mechanical system or *equipment* to be reinspected.

The fire chief and the code official each have authority to obtain compliance with the requirements of this subsection.

Exception: The code official may modify the requirements of this section where all or a portion of the building is unoccupied.

104.5 Moved buildings. Building or structures moved into or within the City shall comply with standards adopted by the code official. No building shall be moved into or within the City unless, prior to moving, the code official has inspected the building for compliance with this code and the permit holder has agreed to correct all deficiencies found and has been issued a building permit for the work. A bond or cash deposit in an amount sufficient to abate or demolish the building shall be posted prior to issuance of a permit. See Section 114 for information required on plans. Any moved building that is not in complete compliance with standards for moved buildings within eighteen months from the date of permit issuance and is found to be a public nuisance may be abated.

104.6 Landmarks—Historic buildings and structures. The code official may modify the specific requirements of this code as it applies to landmarks and require in lieu thereof alternate requirements that, in the opinion of the code official, will result in a reasonable degree of safety to the public and the occupants of those buildings.

For purposes of this section a landmark is a building or structure: that is subject to a requirement to obtain a certificate of approval from the City Landmarks Preservation Board before altering or making significant changes to specific features or

characteristics, that has been nominated for designation and the City Landmarks Preservation Board has not issued a determination regarding designation, that has been designated for preservation by the City Landmarks Preservation Board, that has been designated for preservation by the State of Washington, that has been listed or determined eligible to be listed in the National Register of Historic Places, or that is located in a landmark or special review district subject to a requirement to obtain a certificate of approval before making a change to the external appearance of a structure.

SECTION 105 ALTERNATE MATERIALS AND METHODS OF CONSTRUCTION

105.1 Alternate materials and methods of construction and design. This code does not prevent the use of any material, design or method of construction not specifically allowed or prohibited by this code, provided the alternate has been *approved* and its use authorized by the code official. The code official may approve an alternate, provided the code official finds that the proposed alternate complies with the provisions of this code and that the alternate, when considered together with other safety features of the building or other relevant circumstances, will provide at least an equivalent level of strength, effectiveness, fire resistance, durability, safety and sanitation. The code official may require that sufficient evidence or proof be submitted to reasonably substantiate any claims regarding the use or suitability of the alternate. The code official may, but is not required to, record the approval of alternates and any relevant information in the files of the code official or on the *approved* construction documents.

SECTION 106 MODIFICATIONS

106.1 Modifications. The code official may modify the provisions of this code for individual cases if the code official finds: (1) there are practical difficulties involved in carrying out the provisions of this code; (2) the modification is in conformity with the intent and purpose of this code; and (3) the modification will provide a reasonable level of strength, effectiveness, fire resistance, durability, safety and sanitation when considered together with other safety features of the building or other relevant circumstances. The code official may, but is not required to, record the approval of modifications and any relevant information in the files of the code official or on the *approved* construction documents.

SECTION 107 TESTS

107.1 Tests. Whenever there is insufficient evidence of compliance with the provisions of this code or evidence that any material or method of construction does not conform to the requirements of this code, the code official may require tests as proof of compliance, to be made at no expense to the City. Test methods shall be as specified in this code or by other recognized test standards. If there are no recognized and accepted test methods for the proposed alternate, the code official shall determine the test procedures. All tests shall be made by an *approved* agency. Reports of such tests shall be retained by the code official for the period required for retention of public records.

SECTION 108 ORGANIZATION AND DUTIES OF CODE OFFICIAL

108.1 Jurisdiction of the Department of Construction and Inspections. The Department of Construction and Inspections is authorized to administer and enforce this code. The Department of Construction and Inspections is under the administrative and operational control of the Director, who is the code official.

108.2 Designees. The code official may appoint such officers, inspectors, assistants and employees as are authorized from time to time. The code official may authorize such employees and other agents as may be necessary to carry out the functions of the code official.

108.3 Right of entry. With the consent of the owner or occupier of a building or premises, or pursuant to a lawfully issued warrant, the code official may enter a building or premises at any reasonable time to perform the duties imposed by this code.

108.4 Liability. Nothing in this code is intended to be nor shall be construed to create or form the basis for any liability on the part of the City, or its officers, employees or agents, for any injury or damage resulting from the failure of *equipment* to conform to the provisions of this code, or by reason or as a consequence of any inspection, notice, order, certificate, permission or approval authorized or issued or done in connection with the implementation or enforcement of this code, or by reason of any action or inaction on the part of the City related in any manner to the enforcement of this code by its officers, employees or agents.

This code shall not be construed to lessen or relieve the responsibility of any *person* owning, operating or controlling any *equipment*, building or structure for any damages to *persons* or property caused by defects, nor shall the Seattle Department of

SCOPE AND ADMINISTRATION

Construction and Inspections or the City of Seattle be held to have assumed any such liability by reason of the inspections authorized by this code or any permits or certificates issued under this code.

108.5 Responsibility for compliance. Compliance with the requirements of this code is the obligation of the owner of the building, structure or premises, the authorized agent of the owner, and other *persons* responsible for the condition or work, and not of the City or any of its officers, employees or agents.

SECTION 109 UNSAFE EQUIPMENT AND HAZARD CORRECTION ORDER

109.1 Emergency order. Whenever the code official finds that any *equipment* regulated by this code is in such a dangerous and *unsafe* condition as to constitute an imminent hazard to life or limb, the code official may issue an emergency order. The emergency order may (1) direct that the *equipment* be restored to a safe condition by a date certain; (2) require that the building, structure or premises, or portion thereof, containing the *equipment* be vacated within a reasonable time to be specified in the order, or in the case of extreme danger, the order may specify immediate vacation of the building, structure or premises, or portion thereof; or (3) authorize immediate disconnection of the utilities or energy source.

109.1.1 Service of emergency order. The order shall be posted on the premises or personally served on the owner of the building or premises or any *person* responsible for the condition. The order shall specify the time for compliance.

109.1.2 Effect of emergency order. No *person* may occupy a building, structure or premises, or portion thereof, after the date on which the building is required to be vacated until the building, structure or premises, or portion thereof, is restored to a safe condition as required by the order and this code. It is a violation for any *person* to fail to comply with an emergency order issued by the code official.

109.2 Hazard correction order. Whenever the code official finds that *unsafe equipment* exists, the code official may issue a hazard correction order specifying the conditions causing the *equipment* to be *unsafe* and directing the owner or other *person* responsible for the *unsafe equipment* to correct the condition by a date certain. In lieu of correction, the owner may submit a report or analysis to the code official analyzing said conditions and establishing that the *equipment* is, in fact, safe. The code official may require that the report or analysis be prepared by a licensed engineer.

109.2.1 Service of hazard correction order. The order shall be served upon the owner, agent or other responsible *person* by personal service or regular first class mail addressed to the last known address of such *person* or if no address is available after reasonable inquiry, the order may be posted in a conspicuous place on the premises. The order may also be posted if served by personal service or first class mail.

109.2.2 Effect of hazard correction order. It is a violation for any *person* to fail to comply with a hazard correction order as specified in this subsection.

SECTION 110 ENFORCEMENT, VIOLATIONS AND PENALTIES

110.1 Violations. It is a violation of this code for any *person* to:

1. Install, erect, construct, enlarge, alter, repair, replace, remodel, move, improve, remove, convert or demolish, equip, occupy, use or maintain any mechanical system or *equipment*, or cause or permit the same to be done, in the City, contrary to or in violation of any of the provisions of this code.
2. Knowingly aid, abet, counsel, encourage, hire, induce or otherwise procure another to violate or fail to comply with this code.
3. Use any material or install any device, appliance or *equipment* that is subject to this code and has not been *approved* by the code official.
4. Violate or fail to comply with any order issued by the code official pursuant to the provisions of this code or with any requirements of this code.
5. Remove, mutilate, destroy or conceal any notice or order issued or posted by the code official pursuant to the provisions of this code, or any notice or order issued or posted by the code official in response to a natural disaster or other emergency.
6. Conduct work under a permit without requesting an inspection as required by Section 116.

110.2 Notice of violation. If, after investigation, the code official determines that standards or requirements of this code have been violated or that orders or requirements have not been complied with, the code official may issue a notice of violation upon the owner, agent, or other *person* responsible for the action or condition. The notice of violation shall state the standards or requirements violated, shall state what corrective action, if any, is necessary to comply with the standards or requirements, and shall set a reasonable time for compliance.

110.2.1 Service of notice of violation. The notice shall be served upon the owner, agent or other responsible *person* by personal service or regular first class mail addressed to the last known address of such *person*, or if no address is available after reasonable inquiry, the notice may be posted in a conspicuous place on the premises. The notice may also be posted if served by personal service or first class mail. Nothing in this section limits or precludes any action or proceeding to enforce this code, and nothing obligates or requires the code official to issue a notice of violation prior to the imposition of civil or criminal penalties.

110.2.2 Review of notice of violation by the code official. Any *person* affected by a notice of violation issued pursuant to Section 110.2 may obtain a review of the notice by making a request in writing to the code official within ten days after service of the notice. When the last day of the period computed is a Saturday, Sunday, or city holiday, the period runs until 5 p.m. of the next business day.

110.2.2.1 Review procedure. The review shall occur not less than ten nor more than 20 days after the request is received by the code official unless otherwise agreed to by the *person* requesting the review. Any *person* affected by the notice of violation may submit additional information to the code official. The review shall be made by a representative of the code official who will review any additional information that is submitted and the basis for issuance of the notice of violation. The reviewer may request clarification of the information received and a site visit.

110.2.2.2 Decision. After the review, the code official shall:

1. Sustain the notice;
2. Withdraw the notice;
3. Amend the notice; or
4. Continue the review to a date certain.

110.2.2.3 Order. The code official shall issue an order containing the decision within 15 days of the date that the review is completed and shall cause the order to be mailed by regular first class mail to the *persons* requesting the review and the *persons* named on the notice of violation, addressed to their last known address.

110.3 Stop work orders. The code official may issue a stop work order whenever any work is being done contrary to the provisions of this code, or contrary to a permit issued by the code official, or in the event of dangerous or *unsafe* conditions related to *equipment* or construction. The stop work order shall identify the violation and may prohibit work or other activity on the site.

110.3.1 Service of stop work order. The code official shall serve the stop work order by posting it in a conspicuous place at the site. If posting is not physically possible, the stop work order may be served by personal service or by regular first class mail to the last known address of: the property owner, the *person* doing or causing the work to be done, or the holder of a permit if work is being stopped on a permit. For purposes of this section, service is complete at the time of posting or of personal service, or if mailed, three days after the date of mailing. When the last day of the period so computed is a Saturday, Sunday or city holiday, the period runs until 5 p.m. on the next business day.

110.3.2 Effective date of stop work order. Stop work orders are effective when posted, or if posting is not physically possible, when one of the *persons* identified in Section 110.3.1 is served.

110.3.3 Review of stop work orders by the code official. Any *person* aggrieved by a stop work order may obtain a review of the order by delivering to the code official a request in writing within two business days of the date of service of the stop work order.

110.3.3.1 Review procedure. The review shall occur within two business days after receipt by the code official of the request for review unless otherwise agreed by the *person* making the request. Any *person* affected by the stop work order may submit additional information to the code official for consideration as part of the review at any time prior to the review. The review will be made by a representative of the code official who will review all additional information received and may also request a site visit.

110.3.3.2 Decision. After the review, the code official may:

1. Sustain the stop work order;
2. Withdraw the stop work order;
3. Modify the stop work order; or
4. Continue the review to a date certain.

110.3.3.3 Order. The code official shall issue an order containing the decision within two business days after the review is completed and shall cause the order to be sent by regular first class mail to the *person* or *persons* requesting the review, any *person* on whom the stop work order was served, and any other *person* who requested a copy before issuance of the order, addressed to their last known address.

110.4 Authority to disconnect utilities in emergencies. The code official has the authority to disconnect fuel-gas utility service or energy supplies to a building, structure, premises or *equipment* regulated by this code in case of emergency where nec-

SCOPE AND ADMINISTRATION

essary to eliminate an immediate hazard to life or property. The code official may enter any building or premises to disconnect utility service. The code official shall, whenever possible, notify the serving utility, the owner and the occupant of the building, structure or premises of the decision to disconnect prior to taking such action, and shall notify the serving utility, owner and occupant of the building, structure or premises in writing of such disconnection immediately thereafter.

110.5 Authority to condemn equipment. Whenever the code official determines that any *equipment* or portion thereof regulated by this code is hazardous to life, health or property, the code official shall order in writing that such *equipment* either be disconnected, removed or restored to a safe or sanitary condition, as appropriate. The written notice shall fix a date certain for compliance with such order. It is a violation for any *person* to use or maintain defective *equipment* after receiving such notice. When any *equipment* or installation is to be disconnected, the code official shall give written notice of such disconnection and causes therefore within 24 hours to the serving utility, the owner and the occupant of the building, structure or premises. When any *equipment* is maintained in violation of this code, and in violation of a notice issued pursuant to the provisions of this section, the code official shall institute any appropriate action to prevent, restrain, correct or abate the violation.

110.6 Connection after order to disconnect. No *person* shall make connections from any energy, fuel or power supply nor supply energy or fuel to any *equipment* regulated by this code that has been disconnected or ordered to be disconnected by the code official, or the use of which has been ordered to be discontinued by the code official until the code official authorizes the reconnection and use of such *equipment*.

110.7 Civil penalties. Any *person* violating or failing to comply with the provisions of this code is subject to a cumulative civil penalty in an amount not to exceed \$500 per day for each violation from the date the violation occurs or begins until the date compliance is achieved. In cases where the code official has issued a notice of violation, the violation will be deemed to begin, for purposes of determining the number of days of violation, on the date compliance is required by the notice of violation.

110.8 Enforcement in Municipal Court. Civil actions to enforce this code shall be brought exclusively in Seattle Municipal Court, except as otherwise required by law or court rule. In any civil action for a penalty, the City has the burden of proving by a preponderance of the evidence that a violation exists or existed; the issuance of a notice of violation or of an order following a review by the code official is not itself evidence that a violation exists.

110.9 Judicial review. Because civil actions to enforce this code must be brought exclusively in Seattle Municipal Court pursuant to Section 111.8, orders of the code official, including notices of violation issued under this chapter, are not subject to judicial review pursuant to chapter 36.70C RCW.

110.10 Alternative criminal penalty. Anyone who violates or fails to comply with any notice of violation or order issued by the code official pursuant to this code or who removes, mutilates, destroys or conceals a notice issued or posted by the code official shall, upon conviction thereof, be punished by a fine of not more than \$5,000 or by imprisonment for not more than 365 days, or by both such fine and imprisonment for each separate violation. Each day's violation shall constitute a separate offense.

110.11 Additional relief. The code official may seek legal or equitable relief to enjoin any acts or practices and abate any condition when necessary to achieve compliance.

110.12 Administrative review by the code official. Prior to issuance of the mechanical permit, applicants may request administrative review by the code official of decisions or actions pertaining to the administration and enforcement of this code. Requests shall be addressed to the code official.

110.13 Administrative review by the Construction Codes Advisory Board. After administrative review by the code official, and prior to issuance of the mechanical permit, applicants may request review of decisions or actions pertaining to the application and interpretation of this code by the Construction Codes Advisory Board according to International Building Code Section 103.11, except for stop work orders, notices of violations and revocations of permits. The review will be performed by three or more members of the Construction Codes Advisory Board, chosen by the Board Chair. The Chair shall consider the subject of the review and members' expertise when electing members to conduct a review. The decision of the review panel is advisory only; the final decision is made by the code official.

110.14 Recording. The code official may record a copy of any order or notice with the Department of Records and Elections of King County.

110.15 Appeal to Superior Court. Final decisions of the Seattle Municipal Court on enforcement actions authorized by Title 22 and this code may be appealed pursuant to the Rules for Appeal of Decisions of Courts of Limited Jurisdiction.

SECTION 111 RULES OF THE CODE OFFICIAL

111.1 Authority. The code official has authority to issue interpretations of this code and to adopt and enforce rules and regulations supplemental to this code as may be deemed necessary to clarify the application of the provisions of this code. Such interpretations, rules and regulations shall be in conformity with the intent and purpose of this code.

111.2 Procedure for adoption of rules. The code official shall promulgate, adopt and issue rules according to the procedures specified in the Administrative Code, Chapter 3.02 of the Seattle Municipal Code.

SECTION 112 CONSTRUCTION CODES ADVISORY BOARD

112.1 Construction Codes Advisory Board committee. A committee of the Construction Codes Advisory Board may examine proposed administrative rules, and amendments relating to this code and related provisions of other codes and make recommendations to the code official and to the City Council for changes in this code. The committee will be called on as needed by the Construction Codes Advisory Board.

SECTION 113 PERMITS

113.1 Permits required. Except as otherwise specifically provided in this code, a permit shall be obtained from the code official prior to each installation, *alteration*, repair, replacement or remodel of any *equipment* or mechanical system regulated by this code. A separate mechanical permit is required for each separate building or structure.

113.2 Work exempt from permit.

113.2.1 Mechanical. A mechanical permit is not required for the work listed below.

1. Portable heating appliances, portable ventilating *equipment*, and portable cooling units, if the total capacity of these portable appliances does not exceed 40 percent of the cumulative heating, cooling or ventilating requirements of a building or *dwelling unit* and does not exceed 3 kW or 10,000 Btu input.
2. Any closed system of steam, hot or chilled water piping within heating or cooling *equipment* regulated by this code.
3. Minor work or the replacement of any component part of a mechanical system that does not alter its original approval and complies with other applicable requirements of this code.

113.2.2 Refrigeration. A mechanical permit is not required for the following refrigerant *equipment*:

1. Any self-contained refrigerating *equipment* for which an operating permit is not required.
2. Any self-contained refrigeration system that does not exceed three horsepower rating.

113.3 Compliance required. All work shall comply with this code, even where no permit is required.

113.4 Flood hazard areas. In addition to the permit required by this section, all work to be performed in areas of special flood hazard as defined in Chapter 25.06 of the *Seattle Municipal Code*, subject to additional standards and requirements set forth in Chapter 25.06, the Seattle Floodplain Development Ordinance.

113.5 Emergency repairs. In the case of an emergency, the installation, *alteration* or repair of any refrigeration system or *equipment* may be made without a permit, provided that application for a permit is made within the later of 24 hours or one working day from the time when the emergency work was started.

SECTION 114 APPLICATION FOR PERMIT

114.1 Application. To obtain a permit, the applicant shall first file an application in a format determined by the code official. Every such application shall:

1. Identify and describe the work to be covered by the permit for which application is made.
2. Describe the land on which the proposed work is to be done by legal description, property address or similar description that will readily identify and definitely locate the proposed building or work.
3. Provide the contractor's business name, address, phone number and current contractor registration number (required if contractor has been selected). To obtain a permit for work on a refrigeration system, the applicant shall also provide the number of the refrigeration contractor license issued by the City.
4. Be accompanied by construction documents, including plans, diagrams, computations and specifications, *equipment* schedules and other data as required in Sections 114.2 and 114.3.
5. State the valuation of the mechanical work to be done. The valuation of the mechanical work is the estimated current value of all labor and material, whether actually paid for or not, for which the permit is sought.
6. Be signed by the owner of the property or building, or the owner's authorized agent, who may be required to submit evidence to indicate such authority.
7. Give such other data and information as may be required by the code official.

SCOPE AND ADMINISTRATION

8. State the name of the owner and the name, address and phone number of a contact *person*.
9. Substantially conform with applicable law in effect on the date described in Section R101.3, as modified by any exception.

114.2 Construction documents. Construction documents shall be submitted in one or more sets with each application for a permit, or shall be submitted in electronic format determined by the code official. The code official may require plans, computations and specifications to be prepared and designed by an engineer or architect licensed by the state to practice as such. Projects having a total mechanical valuation of \$50,000 or larger shall have a mechanical engineering stamp and signature on each sheet.

Exception: A mechanical engineer's stamp or submission of construction documents is not required if the code official finds that the nature of the work applied for is such that review of construction documents is not necessary to obtain compliance with this code.

114.3 Information on construction documents.

114.3.1 Clarity of plans. Plans shall be drawn to a clearly indicated and commonly accepted scale in a format determined by the code official.

114.3.2 Fire-resistive notes. The code official may require that plans for buildings more than two stories in height of other than Group R-3 and Group U *occupancies* indicate how required structural and fire-resistive integrity will be maintained where a penetration will be made for electrical, mechanical, plumbing and communication conduits, pipes and similar systems.

114.3.3 Information required on plans. The plans or specifications shall show the following:

1. Layout for each floor with dimensions of all working spaces and a legend of all symbols used.
2. Location, size and material of all piping.
3. Location, size and materials of all air ducts, air inlets and air outlets.
4. Location of all fans, warm-air furnaces, boilers, absorption units, refrigerant compressors and condensers and the weight of all pieces of such *equipment* weighing 200 pounds or more.
5. Rated capacity or horsepower and efficiency rating of all boilers, warm-air furnaces, heat exchangers, blower fans, refrigerant compressors and absorption units. See also the *International Energy Conservation Code*.
6. Location, size and material of all *combustion* products vents and *chimneys*.
7. Location and area of all ventilation and *combustion* air openings and ducts.
8. Location of all air dampers and fire shutters.
9. The first sheet of each set of plans and specifications shall show the address of the proposed work and the name and address of the owner or lessee of the premises.
10. Architectural drawings, typical envelope cross sections and other drawings or data may be required to support system sizing calculations or other thermal requirements of this code or the *International Energy Conservation Code*.

SECTION 115 APPLICATION REVIEW AND PERMIT ISSUANCE

115.1 Issuance. The application and construction documents shall be reviewed by the code official. The construction documents may be reviewed by other departments of the City to check compliance with the laws and ordinances under their jurisdiction.

115.1.1 Issuance of permit. The code official shall issue a permit to the applicant if the code official finds the following:

1. The work described in the construction documents substantially conforms to the requirements of this code and other pertinent laws and ordinances;
2. The fees specified in the Seattle Municipal Code, Title 22, Subtitle IX, Permit Fees have been paid; and
3. The applicant has complied with all requirements to be performed prior to issuance of a permit for the work under other pertinent laws, ordinances or regulations or included in a master use permit, or otherwise imposed by the building official.

When the permit is issued, the applicant or the applicant's authorized agent becomes the permit holder.

115.1.2 Compliance with approved construction documents. When the code official issues a permit, the code official shall endorse the permit in writing or in electronic format and stamp the plans "APPROVED." Such *approved* plans and permit shall not be changed, modified or altered without authorization from the code official, and all work shall be done in

accordance with the *approved* construction documents and permit except as authorized by the code official during a field inspection to correct errors or omissions, or as authorized by Section 115.2.

115.2 Revisions to the permit. When changes to the *approved* work are made during construction, approval of the code official shall be obtained prior to execution. The building or mechanical inspector may approve minor changes for work not reducing the structural strength or fire and life safety of the structure. The building or mechanical inspector shall determine if it is necessary to revise the *approved* construction documents. If revised plans are required, changes shall be submitted to and *approved* by the code official, accompanied by fees specified in the Seattle Municipal Code, Title 22, Subtitle IX, Permit Fees prior to *occupancy*. All changes shall conform to the requirements of this code and other pertinent laws and ordinances and other issued permits.

Minor changes shall not incur additional fees if these changes do not (1) add to the general scope of work; (2) change the basic design concept; (3) involve major relocation of *equipment*, ducts, or pipes; (4) substantially alter *approved equipment* size; or (5) require extensive re-review of the plans and specifications.

115.3 Cancellation of permit applications. Applications may be cancelled if no permit is issued by the earlier of the following: (1) 12 months following the date of application; or (2) 60 days after the date of written notice that the permit is ready to be issued. After cancellation, construction documents may be returned to the applicant or destroyed by the code official.

The code official shall notify the applicant in writing at least 30 days before the application is cancelled. The notice shall specify a date by which a request for extension must be submitted in order to avoid cancellation. The date shall be at least two weeks prior to the date on which the application will be cancelled.

115.4 Extensions prior to permit issuance. At the discretion of the code official, applications for projects that require more than 12 months to review and approve may be extended for a period that provides reasonable time to complete the review and approval, but in no case longer than 24 months from the date of the original application. No application may be extended more than once. After cancellation, the applicant shall submit a new application and pay a new fee to restart the permit process.

Notwithstanding other provisions of this code, applications may be extended where issuance of the permit is delayed by litigation, preparation of environmental impact statements, appeals, strikes or other causes related to the application that are beyond the applicant's control, or while the applicant is making progress toward issuance of a master use permit.

115.5 Retention of plans. One set of *approved* plans, which may be on microfilm or in electronic format, shall be retained by the code official. One set of *approved* plans shall be returned to the applicant and shall be kept at the site of the building or work for use by the inspection personnel at all times when the work authorized is in progress.

115.6 Validity of permit. The issuance or granting of a permit or approval of construction documents shall:

1. Not be construed to be a permit for, or an approval of, any violation of any of the provisions of this code or other pertinent laws and ordinances.
2. Not prevent the code official from requiring the correction of errors in the construction documents, or from preventing building operations being carried on thereunder when in violation of this code or of other pertinent laws and ordinances of the City.
3. Not prevent the code official from requiring correction of conditions found to be in violation of this code or other pertinent laws and ordinances of the City, or
4. Not be construed to extend the period of time for which any such permit is issued or otherwise affect any period of time for compliance specified in any notice or order issued by the code official or other administrative authority requiring the correction of any such conditions.

115.7 Expiration of permits. Authority to do the work authorized by a permit expires 18 months from the date of issuance. An *approved* renewal extends the life of a permit for an additional 18 months from the prior expiration date. An *approved* reestablishment extends the life of the permit for 18 months from the date the permit expired.

Exceptions:

1. Initial permits for major construction projects that require more than 18 months to complete may be issued for a period that provides reasonable time to complete the work, according to an *approved* construction schedule. The building official may authorize a permit expiration date not to exceed three years from the date of issuance.
2. The code official may issue permits that expire in less than 18 months if the code official determines a shorter period is appropriate to complete the work.

115.8 Renewal of permits. Permits may be renewed and renewed permits may be further renewed by the code official, if the following conditions are met:

1. Application for renewal is made within the 30 day period immediately preceding the date of expiration of the permit; and
2. If the project has had an associated discretionary Land Use review, and the land use approval has not expired; and

3. If an application for renewal is made more than 18 months after the date of mandatory compliance with a new or revised edition of this code, the permit shall not be renewed unless:
 - 3.1. The code official determines that the permit complies, or is modified to comply with the Seattle Mechanical, Fuel Gas and Energy codes in effect on the date of application for renewal; or
 - 3.2. The work authorized by the permit is substantially underway and progressing at a rate *approved* by the building official. “Substantially underway” means that normally required inspections have been *approved* for work such as foundations, framing, mechanical, insulation and finish work is being completed on a continuing basis; or
 - 3.3. Commencement or completion of the work authorized by the permit is delayed by litigation, appeals, strikes or other extraordinary circumstances related to the work authorized by the permit, beyond the permit holder’s control, subject to approval by the code official.

[S] 115.9 Reestablishment of expired permits. A new permit is required to complete work if a permit has expired and was not renewed.

Exception: A permit that expired less than one year prior to the date of a request for reestablishment may be reestablished upon approval of the code official if it complies with Items 2 and 3 of Section 115.8. Once re-established the permit will not be considered to have expired. The new expiration date of a re-established permit shall be determined in accordance with Section 115.7.

115.10 Revocation of mechanical permits. Whenever the code official determines there are grounds for revoking a permit, the code official may issue a notice of revocation. The notice of revocation shall identify the reason for the proposed revocation, including, but not limited to, the violations, the conditions violated, and any alleged false or misleading information provided.

115.10.1 Standards for revocation. The code official may revoke a permit if:

1. The code or the permit has been or is being violated and issuance of a notice of violation or stop work order has been or would be ineffective to secure compliance because of circumstances related to the violation; or
2. The permit was obtained with false or misleading information.

115.10.2 Service of notice of revocation. The notice of revocation shall be served upon the owner, agent or other responsible *person* by personal service or regular first class mail addressed to the last known address of such *person* or if no address is available after reasonable inquiry, the notice may be posted in a conspicuous place on the premises. The notice may also be posted if served by personal service or first class mail.

115.10.3 Effective date of revocation. The code official shall identify in the notice of revocation a date certain on which the revocation will take effect. This date may be stayed pending complete review by the code official pursuant to Section 115.10.4.

115.10.4 Review by the code official for notice of revocation. Any *person* aggrieved by a notice of revocation may obtain a review by making a request in writing to the code official within three business days of the date of service of the notice of revocation. The review shall occur within five business days after receipt by the building official of the request for review. Any *person* affected by the notice of revocation may submit additional information to the building official for consideration as part of the review at any time prior to the review.

115.10.4.1 Review procedure. The review will be made by a representative of the code official who will review all additional information received and may also request a site visit. After the review, the code official may:

1. Sustain the notice of revocation and affirm or modify the date the revocation will take effect;
2. Withdraw the notice of revocation;
3. Modify the notice of revocation and affirm or modify the date the revocation will take effect; or
4. Continue the review to a date certain.

115.10.4.2 Order of revocation of permit. The code official shall issue an order containing the decision within ten days after the review is completed and shall cause the same to be sent by regular first class mail to the *person* or *persons* requesting the review, any other *person* on whom the notice of revocation was served, and any other *person* who requested a copy before issuance of the order. The order of the building official is the final order of the City, and the City and all parties shall be bound by the order.

SECTION 116 INSPECTIONS

116.1 General. All construction or work for which a permit is required is subject to inspection by the code official, and certain types of construction shall have special inspections by registered special inspectors specified in Chapter 17 of the *International Building Code*. In addition to the inspections specified above, the code official may make or require any other inspection.

tions of any mechanical work to ascertain compliance with the provisions of this code and other laws and ordinances that are enforced by the code official.

116.2 Inspection requests. The owner of the property or the owner's authorized agent, or the *person* designated by the owner or agent to do the work authorized by a permit shall notify the code official that work requiring inspection as specified in this section and Section 120 is ready for inspection.

116.3 Access for inspection. The permit holder and the *person* requesting any inspections required by this code shall provide access to and means for proper inspection of such work, including safety *equipment* required by the Washington Industrial Safety and Health Agency. The work shall remain accessible and exposed for inspection purposes until *approved* by the code official. Neither the code official nor the City shall be liable for expense entailed in the required removal or replacement of any material to allow inspection.

116.4 Inspection record. Work requiring a mechanical permit shall not be commenced until the permit holder or the permit holder's agent has posted an inspection record in a conspicuous place on the premises and in a position that allows the code official to conveniently make the required entries regarding inspection of the work. This record shall be maintained in such a position by the permit holder or the permit holder's agent until final approval has been granted by the code official.

116.5 Approvals required. No work shall be done on any part of the building or structure beyond the point indicated in each successive inspection without first obtaining the written approval of the code official.

116.5.1 Effect of approval. Approval as a result of an inspection is not approval of any violation of the provisions of this code or of other pertinent laws and ordinances of the City. Inspections presuming to give authority to violate or cancel the provisions of this code or of other pertinent laws and ordinances of the City are not valid.

116.6 Final inspection. When the installation of a mechanical system is complete, an additional and final inspection shall be made.

116.7 Operation of mechanical equipment. The requirements of this section do not prohibit the operation of any mechanical systems installed to replace existing *equipment* or fixtures serving an occupied portion of the building in the event a request for inspection of such *equipment* or fixture has been filed with the code official not more than 48 hours after such replacement work is completed, and before any portion of such mechanical system is concealed by any permanent portion of the building.

116.8 Testing of equipment and systems. Refrigeration *equipment* regulated by this code shall be tested and *approved* as required by Chapter 11 of this code. Fuel-oil piping shall be tested and *approved* as required by Chapter 13 of this code.

116.9 Special investigation. If work that requires a permit or approval is commenced or performed prior to making formal application and receiving the code official's permission to proceed, the code official may make a special investigation inspection before a permit is issued for the work. If a special investigation is made, a special investigation fee may be assessed in accordance with the Fee Subtitle.

116.10 Reinspections. The code official may require a reinspection if work for which inspection is called is not complete, required corrections are not made, the inspection record is not properly posted on the work site, the *approved* plans are not readily available to the inspector, access is not provided on the date for which inspection is requested, if deviations from construction documents that require the approval of the code official have been made without proper approval, or as otherwise required by the code official.

116.10.1 Compliance with Section 104.4. For the purpose of determining compliance with Section 104.4, Maintenance, the code official or the fire chief may cause any structure or system to be reinspected.

116.10.2 Reinspection fee. The code official may assess a reinspection fee as set forth in the *Seattle Municipal Code*, Title 22, Subtitle IX, Permit Fees for any action for which reinspection is required. In instances where reinspection fees have been assessed, no additional inspection of the work will be performed until the required fees have been paid.

SECTION 117 CONNECTION APPROVAL

117.1 Energy connections. No *person* shall make connections from a source of energy fuel to a mechanical system or *equipment* regulated by this code for which a permit is required until *approved* by the code official.

117.2 Temporary connections. The code official may authorize temporary connection of the mechanical *equipment* to the source of energy fuel for the purpose of testing the *equipment*, or for use under a temporary certificate of *occupancy*.

SCOPE AND ADMINISTRATION

SECTION 118 REFRIGERATION LICENSES

118.1 Refrigeration licenses. No *person* shall perform any of the services or activities related to refrigeration systems regulated by Chapter 11 without a license required by Chapter 6.410 of the *Seattle Municipal Code*, or under the direct supervision of a *person* holding a required license.

SECTION 119 OPERATING PERMITS FOR REFRIGERATION SYSTEMS

119.1 An operating permit issued by the code official is required to operate any refrigeration system meeting any one of the following criteria:

1. Any system over 50 horsepower, or
2. Any system over 50 tons of refrigerant effect, or
3. Any system that contains over 150 pounds of refrigerant, or
4. Any system that includes a refrigerant containing a pressure vessel over six inches in diameter with a capacity of more than 5 cubic feet and a design working pressure under 250 psig, or
5. Any system that includes a refrigerant containing a pressure vessel over six inches in diameter having a capacity of one and one-half cubic feet and a design working pressure over 250 psig.

119.2 The operating permit will not be issued until the system has been inspected and *approved* by the code official as safe to operate and in compliance with the provisions of this code. The permit is valid for a period of one year, renewable annually. The permit shall be displayed in a conspicuous place adjacent to the refrigeration system.

SECTION 120 FEES

120.1 Fees. A fee for each mechanical permit and for other activities related to the enforcement of this code shall be paid as set forth in the *Seattle Municipal Code*, Title 22, Subtitle IX, Permit Fees.

CHAPTER 2

DEFINITIONS

User note:

About this chapter: Codes, by their very nature, are technical documents. Every word, term and punctuation mark can add to or change the meaning of a technical requirement. It is necessary to maintain a consensus on the specific meaning of each term contained in the code. Chapter 2 performs this function by stating clearly what specific terms mean for the purposes of the code.

SECTION 201 GENERAL

201.1 Scope. Unless otherwise expressly stated, the following words and terms shall, for the purposes of this code, have the meanings indicated in this chapter.

201.2 Interchangeability. Words used in the present tense include the future; words in the masculine gender include the feminine and neuter; the singular number includes the plural and the plural, the singular.

[S] 201.3 Terms defined in other codes. Where terms are not defined in this code and are defined in the *International Building Code*, *International Fire Code*, *Seattle Electrical Code*, *International Fuel Gas Code* or (~~International~~) *Uniform Plumbing Code*, such terms shall have meanings ascribed to them as in those codes.

201.4 Terms not defined. Where terms are not defined through the methods authorized by this section, such terms shall have ordinarily accepted meanings such as the context implies.

SECTION 202 GENERAL DEFINITIONS

ABRASIVE MATERIALS. Moderately abrasive particulate in high concentrations, and highly abrasive particulate in moderate and high concentrations, such as alumina, bauxite, iron silicate, sand and slag.

ABSORPTION SYSTEM. A refrigerating system in which refrigerant is pressurized by pumping a chemical solution of refrigerant in absorbent, and then separated by the addition of heat in a generator, condensed (to reject heat), expanded, evaporated (to provide refrigeration), and reabsorbed in an absorber to repeat the cycle; the system can be single or multiple effect, the latter using multiple stages or internally cascaded use of heat to improve efficiency.

ACCESS (TO). That which enables a device, *appliance* or *equipment* to be reached by ready access or by a means that first requires the removal or movement of a panel or similar obstruction [see also *Ready access (to)*].

AIR. Air supplied to mechanical *equipment* and *appliances* for *combustion*, ventilation, cooling and similar purposes. Standard air is air at standard temperature and pressure, namely, 70°F (21°C) and 29.92 inches of mercury (101.3 kPa).

AIR, EXHAUST. Air being removed from any space, *appliance* or piece of *equipment* and conveyed directly to the atmosphere by means of openings or ducts.

AIR, MAKEUP. Any combination of outdoor and transfer air intended to replace *exhaust air* and exfiltration.

AIR, OUTDOOR. Ambient air that enters a building through a ventilation system, through intentional openings for natural ventilation, or by infiltration.

AIR, TRANSFER. Air moved from one indoor space to another.

AIR CONDITIONING. The treatment of air so as to control simultaneously the temperature, humidity, cleanness and distribution of the air to meet the requirements of a conditioned space.

AIR DISPERSION SYSTEM. Any diffuser system designed to both convey air within a room, space or area and diffuse air into that space while operating under positive pressure. Systems are commonly constructed of, but not limited to, fabric or plastic film.

AIR DISTRIBUTION SYSTEM. Any system of ducts, *plenums* and air-handling *equipment* that circulates air within a space or spaces and includes systems made up of one or more air-handling units.

AIR-CONDITIONING SYSTEM. A system that consists of heat exchangers, blowers, filters, supply, exhaust and return ducts, and shall include any apparatus installed in connection therewith.

AIR-HANDLING UNIT. A blower or fan used for the purpose of distributing supply air to a room, space or area.

DEFINITIONS

[A] **ALTERATION.** A change in a mechanical system that involves an extension, addition or change to the arrangement, type or purpose of the original installation.

APPLIANCE. A device or apparatus that is manufactured and designed to utilize energy and for which this code provides specific requirements.

APPLIANCE, EXISTING. Any *appliance* regulated by this code that was legally installed prior to the effective date of this code, or for which a permit to install has been issued.

APPLIANCE, VENTED. An *appliance* designed and installed in such a manner that all of the products of *combustion* are conveyed directly from the *appliance* to the outdoor atmosphere through an *approved chimney* or vent system.

APPLIANCE TYPE.

High-heat appliance. Any *appliance* in which the products of *combustion* at the point of entrance to the flue under normal operating conditions have a temperature greater than 2,000°F (1093°C).

Low-heat appliance (residential appliance). Any *appliance* in which the products of *combustion* at the point of entrance to the flue under normal operating conditions have a temperature of 1,000°F (538°C) or less.

Medium-heat appliance. Any *appliance* in which the products of *combustion* at the point of entrance to the flue under normal operating conditions have a temperature of more than 1,000°F (538°C), but not greater than 2,000°F (1093°C).

[A] **APPROVED.** Acceptable to the code official.

[A] **APPROVED AGENCY.** An established and recognized agency that is regularly engaged in conducting tests, furnishing inspection services or furnishing product certification where such agency has been approved by the code official.

[S] ~~(**AUTOMATIC BOILER.** Any class of boiler that is equipped with the controls and limit devices specified in Chapter 10.)~~

[W] **BALANCED WHOLE HOUSE VENTILATION.** Any combination of concurrently operating dwelling or sleeping unit mechanical exhaust and mechanical supply whereby the total mechanical exhaust airflow rate is within 10 percent or 5 cfm, whichever is greater, of the total mechanical supply airflow rate.

BATHROOM. A room containing a bathtub, shower, spa or similar bathing fixture.

[S] ~~**BOILER.** A closed (~~heating appliance intended to supply hot water or steam for space heating, processing or power purposes~~) vessel in which water is heated, steam is generated, steam is superheated, or any combination thereof, under pressure or vacuum by the direct application of heat. (~~Low-pressure boilers operate at pressures less than or equal to 15 pounds per square inch (psi) (103 kPa) for steam and 160 psi (1103 kPa) for water. High pressure boilers operate at pressures exceeding those pressures.~~) The term “boiler” shall also include fired units for heating or vaporizing liquids other than water where these systems are complete within themselves.~~

[S] ~~**BOILER CODE.** The *Seattle Boiler and Pressure Vessel Code*.~~

BOILER ROOM. A room primarily utilized for the installation of a boiler.

BRAZED JOINT. A gastight joint obtained by the joining of metal parts with metallic mixtures or alloys that melt at a temperature above 1,000°F (538°C), but lower than the melting temperature of the parts to be joined.

BRAZING. A metal joining process wherein coalescence is produced by the use of a nonferrous filler metal having a melting point above 1,000°F (538°C), but lower than that of the base metal being joined. The filler material is distributed between the closely fitted surfaces of the joint by capillary attraction.

BREATHING ZONE. The region within an occupied space between planes 3 and 72 inches (76 and 1829 mm) above the floor and more than 2 feet (610 mm) from the walls of the space or from fixed air-conditioning *equipment*.

BTU. Abbreviation for British thermal unit, which is the quantity of heat required to raise the temperature of 1 pound (454 g) of water 1°F (0.56°C) (1 Btu = 1055 J).

[A] **BUILDING.** Any structure utilized or intended for supporting or sheltering any *occupancy*.

[BF] **CEILING RADIATION DAMPER.** A *listed* device installed in a ceiling membrane of a fire-resistance-rated floor/ceiling or roof/ceiling assembly to limit automatically the radiative heat transfer through an air inlet/outlet opening. Ceiling radiation dampers are classified for use in either static systems that will automatically shut down in the event of a fire or in dynamic systems that continue to operate during a fire. A dynamic ceiling radiation damper is tested and rated for closure under elevated temperature airflow.

CHIMNEY. A primarily vertical structure containing one or more flues, for the purpose of carrying gaseous products of *combustion* and air from a fuel-burning *appliance* to the outdoor atmosphere.

Factory-built chimney. A *listed* and *labeled chimney* composed of factory-made components, assembled in the field in accordance with manufacturer’s instructions and the conditions of the listing.

Masonry chimney. A field-constructed *chimney* composed of solid masonry units, bricks, stones or concrete.

Metal chimney. A field-constructed *chimney* of metal.

CHIMNEY CONNECTOR. A pipe that connects a fuel-burning *appliance* to a *chimney*.

CLEARANCE. The minimum distance through air measured between the heat-producing surface of the mechanical *appliance*, device or *equipment* and the surface of the combustible material or assembly.

CLOSED COMBUSTION SOLID-FUEL-BURNING APPLIANCE. A heat-producing *appliance* that employs a *combustion* chamber that does not have openings other than the flue collar, fuel charging door and adjustable openings provided to control the amount of *combustion air* that enters the *combustion* chamber.

CLOTHES DRYER. An *appliance* used to dry wet laundry by means of heat.

[S][A] CODE. These regulations, subsequent amendments thereto, or any emergency rule or regulation that ((~~the administrative authority having jurisdiction~~)) has been lawfully adopted.

[S][A] CODE OFFICIAL. The ((~~officer or other designated authority charged with the administration and enforcement of this code~~)) Director of the Department of Construction and Inspections, or a duly authorized representative.

[BF] COMBINATION FIRE/SMOKE DAMPER. A *listed* device installed in ducts and air transfer openings designed to close automatically upon the detection of heat and resist the passage of flame and smoke. The device is installed to operate automatically, be controlled by a smoke detection system, and where required, is capable of being positioned from a fire command center.

COMBUSTIBLE ASSEMBLY. Wall, floor, ceiling or other assembly constructed of one or more component materials that are not defined as noncombustible.

[F] COMBUSTIBLE LIQUID. A liquid having a closed cup flash point at or above 100°F (38°C). Combustible liquids shall be subdivided as follows:

Class II. Liquids having a closed cup flash point at or above 100°F (38°C) and below 140°F (60°C).

Class IIIA. Liquids having a closed cup flash point at or above 140°F (60°C) and below 200°F (93°C).

Class IIIB. Liquids having a closed cup flash point at or above 200°F (93°C).

The category of combustible liquids does not include compressed gases or cryogenic fluids.

COMBUSTIBLE MATERIAL. Any material not defined as noncombustible.

COMBUSTION. In the context of this code, refers to the rapid oxidation of fuel accompanied by the production of heat or heat and light.

COMBUSTION AIR. Air necessary for complete *combustion* of a fuel, including *theoretical air* and excess air.

COMBUSTION CHAMBER. The portion of an *appliance* within which *combustion* occurs.

COMBUSTION PRODUCTS. Constituents resulting from the *combustion* of a fuel with the oxygen of the air, including the inert gases, but excluding excess air.

COMMERCIAL COOKING APPLIANCES. *Appliances* used in a commercial food service establishment for heating or cooking food. For the purpose of this definition, a commercial food service establishment is where food is prepared for sale or is prepared on a scale that is by volume and frequency not representative of domestic household cooking.

COMMERCIAL COOKING RECIRCULATING SYSTEM. Self-contained system consisting of the exhaust hood, the cooking *equipment*, the filters and the fire suppression system. The system is designed to capture cooking vapors and residues generated from commercial cooking *equipment*. The system removes contaminants from the *exhaust air* and recirculates the air to the space from which it was withdrawn.

COMMERCIAL KITCHEN HOODS.

Backshelf hood. A backshelf hood is also referred to as a low-proximity hood, or as a sidewall hood where wall mounted. Its front lower lip is low over the *appliance(s)* and is “set back” from the front of the *appliance(s)*. It is always closed to the rear of the *appliances* by a panel where free-standing, or by a panel or wall where wall mounted, and its height above the cooking surface varies. (This style of hood can be constructed with partial end panels to increase its effectiveness in capturing the effluent generated by the cooking operation.)

Double island canopy hood. A double island canopy hood is placed over back-to-back *appliances* or *appliance* lines. It is open on all sides and overhangs both fronts and the sides of the *appliance(s)*. It could have a wall panel between the backs of the *appliances*. (The fact that *exhaust air* is drawn from both sides of the double canopy to meet in the center causes each side of this hood to emulate a wall canopy hood, and thus it functions much the same with or without an actual wall panel between the backs of the *appliances*.)

DEFINITIONS

Eyebrow hood. An eyebrow hood is mounted directly to the face of an *appliance*, such as an oven and dishwasher, above the opening(s) or door(s) from which effluent is emitted, extending past the sides and overhanging the front of the opening to capture the effluent.

Pass-over hood. A pass-over hood is a free-standing form of a backshelf hood constructed low enough to pass food over the top.

Single island canopy hood. A single island canopy hood is placed over a single *appliance* or *appliance* line. It is open on all sides and overhangs the front, rear and sides of the *appliance*(s). A single island canopy is more susceptible to cross drafts and requires a greater exhaust airflow than an equivalent sized wall-mounted canopy to capture and contain effluent generated by the cooking operation(s).

Wall canopy hood. A wall canopy exhaust hood is mounted against a wall above a single *appliance* or line of *appliance*(s), or it could be free-standing with a back panel from the rear of the *appliances* to the hood. It overhangs the front and sides of the *appliance*(s) on all open sides.

The wall acts as a back panel, forcing the *makeup air* to be drawn across the front of the cooking *equipment*, thus increasing the effectiveness of the hood to capture and contain effluent generated by the cooking operation(s).

COMPENSATING HOODS. *Compensating hoods* are those having integral (built-in) *makeup air* supply. The *makeup air* supply for such hoods is generally supplied from: short-circuit flow from inside the hood, air curtain flow from the bottom of the front face, and front face discharge from the outside front wall of the hood. The compensating makeup airflow can also be supplied from the rear or side of the hood, or the rear, front or sides of the cooking *equipment*. The makeup airflow can be one or a combination of methods.

COMPRESSOR. A specific machine, with or without accessories, for compressing a gas.

COMPRESSOR, POSITIVE DISPLACEMENT. A compressor in which increase in pressure is attained by changing the internal volume of the compression chamber.

COMPRESSOR UNIT. A compressor with its prime mover and accessories.

CONCEALED LOCATION. A location that cannot be accessed without damaging permanent parts of the building structure or finish surface. Spaces above, below or behind readily removable panels or doors shall not be considered as concealed.

CONDENSATE. The liquid that condenses from a gas (including flue gas) caused by a reduction in temperature.

CONDENSER. A heat exchanger designed to liquefy refrigerant vapor by removal of heat.

CONDENSING UNIT. A specific refrigerating machine combination for a given refrigerant, consisting of one or more power-driven compressors, condensers and, where required, liquid receivers, and the regularly furnished accessories.

[S] CONDITIONED SPACE. An area ((;)) or room ((or space that is enclosed)) within ((the)) a building ((thermal envelope and that is directly heated or cooled or that is indirectly)) being heated or cooled, containing uninsulated ducts, or with a fixed opening directly into an adjacent conditioned space. ((Spaces are indirectly heated or cooled where they communicate through openings with conditioned spaces, where they are separated from conditioned spaces by uninsulated walls, floors or ceilings, or where they contain uninsulated ducts, piping or other sources of heating or cooling.)) Elevator shafts, stair enclosures, enclosed corridors connecting conditioned spaces, and enclosed spaces, through which conditioned air is transferred at a rate exceeding three air changes per hour are considered conditioned spaces for the purpose of the building thermal envelope requirements.

[S] CONFINED SPACE. A space having a volume less than 50 cubic feet per 1,000 Btu per hour (Btu/h) (4.8 m³/kW) of the aggregate input rating of all appliances installed in that space.

[A] CONSTRUCTION DOCUMENTS. The written, graphic and pictorial documents prepared or assembled for describing the design, location and physical characteristics of the elements of the project necessary for obtaining a building permit. The construction drawings shall be drawn to an appropriate scale.

[S] CONTAINER (REFRIGERANT). A cylinder for the transportation of refrigerant.

CONTROL. A manual or automatic device designed to regulate the gas, air, water or electrical supply to, or operation of, a mechanical system.

CONVERSION BURNER. A burner designed to supply gaseous fuel to an *appliance* originally designed to utilize another fuel.

COOKING APPLIANCE. See *Commercial cooking appliances*.

DAMPER. A manually or automatically controlled device to regulate draft or the rate of flow of air or *combustion* gases.

Volume damper. A device that, where installed, will restrict, retard or direct the flow of air in a duct, or the products of *combustion* in a heat-producing *appliance*, its vent connector, vent or *chimney* therefrom.

[BS] DESIGN FLOOD ELEVATION. The elevation of the “design flood,” including wave height, relative to the datum specified on the community’s legally designated flood hazard area map. In areas designated as Zone AO, the *design flood elevation* shall be the elevation of the highest existing grade of the building’s perimeter plus the depth number, in feet (mm), specified on the flood hazard map. In areas designated as Zone AO where a depth number is not specified on the map, the depth number shall be taken as being equal to 2 feet (610 mm).

DESIGN WORKING PRESSURE. The maximum allowable working pressure for which a specific part of a system is designed.

DIRECT EVAPORATIVE COOLING. The evaporative cooling process where water evaporates directly into the air stream, reducing the air’s dry-bulb temperature and raising its humidity level.

[S] DIRECT REFRIGERATION SYSTEM. A system in which the evaporator or condenser of the refrigerating system is in direct contact with the air or other substances to be cooled or heated. See Figure 2-1 for a diagram of a type of direct refrigeration system.

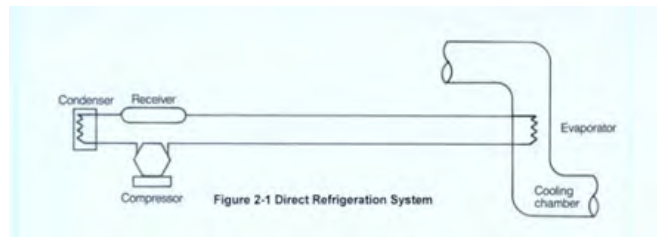

DIRECT SOLAR SYSTEM. A solar thermal system in which the gas or liquid in the solar collector loop is not separated from the load.

[FG] DIRECT-VENT APPLIANCES. *Appliances* that are constructed and installed so that all air for *combustion* is derived from the outdoor atmosphere and all flue gases are discharged to the outdoor atmosphere.

DISCRETE PRODUCT. Products that are noncontinuous, individual, distinct pieces such as, but not limited to, electrical, plumbing and mechanical products and duct straps, duct fittings, duct registers and pipe hangers.

[W] DISTRIBUTED WHOLE HOUSE VENTILATION. A whole house ventilation system shall be considered distributed when it supplies outdoor air directly (not transfer air) to each dwelling or sleeping unit habitable space (living room, den, office, interior adjacent room, interior adjoining spaces or bedroom), and exhausts air from all kitchens and bathrooms directly outside.

DRAFT. The pressure difference existing between the *appliance* or any component part and the atmosphere, that causes a continuous flow of air and products of *combustion* through the gas passages of the *appliance* to the atmosphere.

Induced draft. The pressure difference created by the action of a fan, blower or ejector, that is located between the *appliance* and the *chimney* or vent termination.

Natural draft. The pressure difference created by a vent or *chimney* because of its height, and the temperature difference between the flue gases and the atmosphere.

DRAIN-BACK SYSTEM. A solar thermal system in which the fluid in the solar collector loop is gravity drained from the collector into a holding tank under prescribed circumstances.

DRIP. The container placed at a low point in a system of piping to collect condensate and from which the condensate is removable.

DRY CLEANING SYSTEMS. Dry cleaning plants or systems are classified as follows:

Type I. Those systems using Class I flammable liquid solvents having a flash point below 100°F (38°C).

Type II. Those systems using Class II combustible liquid solvents having a flash point at or above 100°F (38°C) and below 140°F (60°C).

Type III. Those systems using Class III combustible liquid solvents having a flash point at or above 140°F (60°C).

Types IV and V. Those systems using Class IV nonflammable liquid solvents.

DUCT. A tube or conduit utilized for conveying air. The air passages of self-contained systems are not to be construed as air ducts.

DUCT FURNACE. A warm-air furnace normally installed in an air distribution duct to supply warm air for heating. This definition shall apply only to a warm-air heating *appliance* that, for air circulation, depends on a blower not furnished as part of the furnace.

DEFINITIONS

DUCT SYSTEM. A continuous passageway for the transmission of air that, in addition to ducts, includes duct fittings, dampers, *plenums*, fans and accessory air-handling *equipment* and *appliances*.

DUCTLESS MINI-SPLIT SYSTEM. A heating and cooling system that is comprised of one or multiple indoor evaporator/air-handling units and an outdoor condensing unit that is connected by refrigerant piping and electrical wiring. A ductless mini-split system is capable of cooling or heating one or more rooms without the use of a traditional ductwork system.

[BG] DWELLING. A building or portion thereof that contains not more than two *dwelling* units.

[A] DWELLING UNIT. A single unit providing complete, independent living facilities for one or more persons, including permanent provisions for living, sleeping, eating, cooking and sanitation.

ELECTRIC HEATING APPLIANCE. An *appliance* that produces heat energy to create a warm environment by the application of electric power to resistance elements, refrigerant compressors or dissimilar material junctions.

[W] ENCLOSED KITCHEN. A kitchen whose permanent openings to *interior adjacent spaces* do not exceed a total of 60 square feet (6 m²).

ENERGY RECOVERY VENTILATION SYSTEM. Systems that employ air-to-air heat exchangers to recover energy from or reject energy to *exhaust air* for the purpose of preheating, precooling, humidifying or dehumidifying outdoor *ventilation air* prior to supplying such air to a space, either directly or as part of an HVAC system.

[S] ENVIRONMENTAL AIR. Air that is, at temperatures not exceeding 250°F (121°C), conveyed to or from occupied areas through ducts that are not part of the heating or air-conditioning system, such as ventilation for human usage, relief air other than relief air from individual dwelling units or sleeping units, domestic kitchen range exhaust, bathroom exhaust, domestic clothes dryer exhaust, transformer vault exhaust, elevator exhaust, and parking garage exhaust.

EQUIPMENT. Piping, ducts, vents, control devices and other components of systems other than *appliances* that are permanently installed and integrated to provide control of environmental conditions for buildings. This definition shall also include other systems specifically regulated in this code.

EQUIPMENT, EXISTING. Any *equipment* regulated by this code which was legally installed prior to the effective date of this code, or for which a permit to install has been issued.

EVAPORATIVE COOLER. A device used for reducing the sensible heat of air for cooling by the process of evaporation of water into an airstream.

EVAPORATIVE COOLING SYSTEM. The *equipment* and *appliances* intended or installed for the purpose of environmental cooling by an evaporative cooler from which the conditioned air is distributed through ducts or *plenums* to the conditioned area.

EVAPORATOR. That part of the system in which liquid refrigerant is vaporized to produce refrigeration.

EXCESS AIR. The amount of air provided in addition to *theoretical air* to achieve complete *combustion* of a fuel, thereby preventing the formation of dangerous products of *combustion*.

EXFILTRATION. Uncontrolled outward air leakage from conditioned spaces through unintentional openings in ceilings, floors and walls to unconditioned spaces or the outdoors caused by pressure differences across these openings resulting from wind, the stack effect created by temperature differences between indoors and outdoors, and imbalances between supply and exhaust airflow rates.

EXHAUST SYSTEM. An assembly of connected ducts, *plenums*, fittings, registers, grilles and hoods through which air is conducted from the space or spaces and exhausted to the outdoor atmosphere.

[S] EXIT PASSAGEWAY. An exit component that provides a protected path of egress travel in a horizontal direction to an exit or to the exit discharge.

Note: The exit passageway definition is a portion of the same definition found in the 2021 Seattle Building Code.

[BE] EXIT PASSAGEWAY. An *exit* component that is separated from other interior spaces of a building or structure by fire-resistance-rated construction and opening protectives, and provides for a protected path of egress travel in a horizontal direction to an *exit* or to the *exit discharge*.

EXTRA-HEAVY-DUTY COOKING APPLIANCE. Extra-heavy-duty cooking *appliances* are those utilizing open flame combustion of solid fuel at any time.

[S] FIRE AREA. The aggregate floor area enclosed and bounded by fire walls, fire barriers, exterior walls or horizontal assemblies of a building. Areas of the building not provided with surrounding walls shall be included in the fire area if such areas are included within the horizontal projection of the roof or floor next above.

DEFINITIONS

FURNACE. A completely self-contained heating unit that is designed to supply heated air to spaces remote from or adjacent to the *appliance* location.

FURNACE ROOM. A room primarily utilized for the installation of fuel-burning, space-heating and water-heating *appliances* other than boilers (see also *Boiler room*).

FUSIBLE PLUG. A device arranged to relieve pressure by operation of a fusible member at a predetermined temperature.

[S][F] GAS ROOM. A separately ventilated, fully enclosed room in which only compressed gases and associated equipment and supplies are stored or used.

GROUND SOURCE HEAT PUMP LOOP SYSTEM. Piping buried in horizontal or vertical excavations or placed in a body of water for the purpose of transporting heat transfer liquid to and from a heat pump. Included in this definition are closed loop systems in which the liquid is recirculated and open loop systems in which the liquid is drawn from a well or other source.

HAZARDOUS LOCATION. Any location considered to be a fire hazard for flammable vapors, dust, combustible fibers or other highly combustible substances. The location is not necessarily categorized in the *International Building Code* as a high-hazard use group classification.

HEAT EXCHANGER. A device that transfers heat from one medium to another.

HEAT PUMP. A refrigeration system that extracts heat from one substance and transfers it to another portion of the same substance or to a second substance at a higher temperature for a beneficial purpose.

HEAT TRANSFER LIQUID. The operating or thermal storage liquid in a mechanical system, including water or other liquid base, and additives at the concentration present under operating conditions used to move heat from one location to another. Refrigerants are not included as heat transfer liquids.

HEAVY-DUTY COOKING APPLIANCE. Heavy-duty cooking *appliances* include electric under-fired broilers, electric chain (conveyor) broilers, gas under-fired broilers, gas chain (conveyor) broilers, gas open-burner ranges (with or without oven), electric and gas wok ranges, smokers, smoker ovens, and electric and gas over-fired (upright) broilers and salamanders.

HIGH-PROBABILITY SYSTEMS. A refrigeration system in which the basic design or the location of components is such that a leakage of refrigerant from a failed connection, seal or component will enter an *occupancy* classified area, other than the *machinery room*.

[S][BG] HIGH-RISE BUILDING. A building with an occupied floor located more than 75 feet (22 860 mm) above the lowest level of fire department vehicle access. For the purposes of this definition, an occupied roof with an occupant load of 50 or more in a building that is equipped with an automatic sprinkler system and an occupant load of 10 or more in a building not equipped with an automatic fire sprinkler system are considered to be occupied floors.

HIGH-SIDE PRESSURE. The parts of a refrigerating system subject to condenser pressure.

[S] HOOD. An air intake device used to capture by entrapment, impingement, adhesion or similar means, grease, moisture, heat and similar contaminants before they enter a duct system.

Type I. A kitchen hood for collecting and removing grease vapors and smoke generated from medium-duty, heavy-duty, extra-heavy-duty, and some light-duty cooking appliances. Such hoods are equipped with a fire suppression system.

Type II. A general kitchen hood for collecting and removing steam, vapor, heat, odors and products of combustion generated from some light-duty cooking appliances.

[FG] HYDROGEN GENERATING APPLIANCE. A self-contained package or factory-matched packages of integrated systems for generating gaseous hydrogen. Hydrogen generating *appliances* utilize electrolysis, reformation, chemical, or other processes to generate hydrogen.

IGNITION SOURCE. A flame, spark or hot surface capable of igniting flammable vapors or fumes. Such sources include *appliance* burners, burner ignitors and electrical switching devices.

[F] IMMEDIATELY DANGEROUS TO LIFE OR HEALTH (IDLH). The concentration of airborne contaminants that poses a threat of death, immediate or delayed permanent adverse health effects, or effects that could prevent escape from such an environment. This contaminant concentration level is established by the National Institute of Occupational Safety and Health (NIOSH) based on both toxicity and flammability. It is generally expressed in parts per million by volume (ppm v/v) or milligrams per cubic meter (mg/m³).

INDIRECT EVAPORATIVE COOLING. The evaporative cooling process where water evaporates into a secondary air stream, removing heat from a primary air stream utilizing a heat exchanger.

[S] INDIRECT REFRIGERATION SYSTEM. A system in which a secondary coolant cooled or heated by the refrigerating system is circulated to the air or other substance to be cooled or heated. See Figure 2-2. Indirect systems are distinguished by the following methods of application:

Closed system. A system in which a secondary fluid is either cooled or heated by the refrigerating system and then circulated within a closed circuit in indirect contact with the air or other substance to be cooled or heated.

Double-indirect open-spray system. A system in which the secondary substance for an indirect open-spray system is heated or cooled by an intermediate coolant circulated from a second enclosure.

Open-spray system. A system in which a secondary coolant is cooled or heated by the refrigerating system and then circulated in direct contact with the air or other substance to be cooled or heated.

Vented closed system. A system in which a secondary coolant is cooled or heated by the refrigerating system and then passed through a closed circuit in the air or other substance to be cooled or heated, except that the evaporator or condenser is placed in an open or appropriately vented tank.

[S]

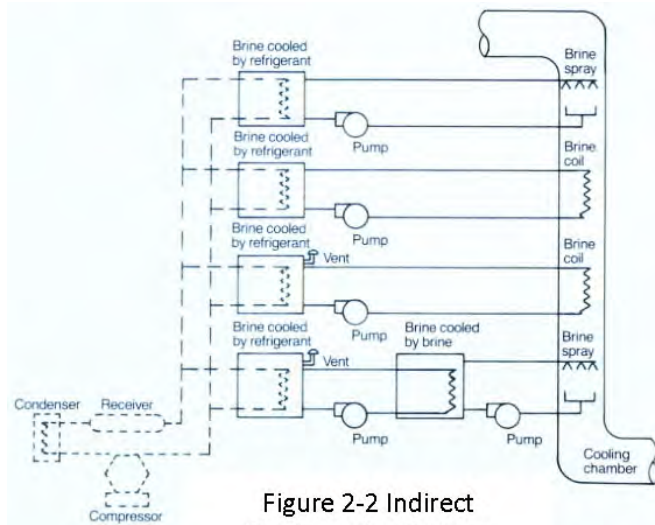

Figure 2-2 Indirect Refrigeration System

INDIRECT SOLAR SYSTEM. A solar thermal system in which the gas or liquid in the solar collector loop circulates between the solar collector and a heat exchanger and such gas or liquid is not drained from the system or supplied to the load during normal operation.

INFILTRATION. Uncontrolled inward air leakage to conditioned spaces through unintentional openings in ceilings, floors and walls from unconditioned spaces or the outdoors caused by pressure differences across these openings resulting from wind, the stack effect created by temperature differences between indoors and outdoors, and imbalances between supply and exhaust airflow rates.

[W] INTERIOR ADJACENT ROOM. An enclosed room without exterior windows or openings to the outdoors located within a dwelling or sleeping unit that does not have interior unobstructed openings required for an interior adjoining space.

[W] INTERIOR ADJOINING SPACE. A room or space without openings to the outdoors that is naturally ventilated from another habitable space by unobstructed fixed openings size in accordance with Section 402.3.

[S] INTERIOR EXIT STAIRWAY. An exit component that serves to meet one or more means of egress design requirements, such as required number of exits or exit access travel distance, and provides for a protected path of egress travel to the exit discharge or public way.

Note: The interior exit stairway definition is identical to the same definition found in Chapter 2 of the 2021 *Seattle Building Code*.

INTERLOCK. A device actuated by another device with which it is directly associated, to govern succeeding operations of the same or allied devices. A circuit in which a given action cannot occur until after one or more other actions have taken place.

JOINT, FLANGED. A joint made by bolting together a pair of flanged ends.

JOINT, FLARED. A metal-to-metal compression joint in which a conical spread is made on the end of a tube that is compressed by a flare nut against a mating flare.

JOINT, PLASTIC ADHESIVE. A joint made in thermoset plastic piping by the use of an adhesive substance that forms a continuous bond between the mating surfaces without dissolving either one of them.

JOINT, PLASTIC HEAT FUSION. A joint made in thermoplastic piping by heating the parts sufficiently to permit fusion of the materials when the parts are pressed together.

DEFINITIONS

JOINT, PLASTIC SOLVENT CEMENT. A joint made in thermoplastic piping by the use of a solvent or solvent cement that forms a continuous bond between the mating surfaces.

JOINT, SOLDERED. A gastight joint obtained by the joining of metal parts with metallic mixtures of alloys that melt at temperatures between 400°F (204°C) and 1,000°F (538°C).

JOINT, WELDED. A gastight joint obtained by the joining of metal parts in molten state.

[A] LABELED. *Equipment*, materials or products to which have been affixed a label, seal, symbol or other identifying mark of a nationally recognized testing laboratory, approved agency or other organization concerned with product evaluation that maintains periodic inspection of the production of the labeled items and whose labeling indicates either that the *equipment*, material or product meets identified standards or has been tested and found suitable for a specified purpose.

LARGE-DIAMETER CEILING FAN. A ceiling fan that is greater than 7 feet (2134 mm) in diameter. These fans are also referred to as high-volume, low-speed (HVLS) fans.

[S] LIGHT-DUTY COOKING APPLIANCE. Light-duty cooking *appliances* include gas and electric ovens of a maximum 6 kW or 20,000 Btu/h capacity (including standard, bake, roasting, revolving, retherm, convection, combination convection/steamer, countertop conveyORIZED baking/finishing, deck and pastry), electric and gas steam-jacketed kettles, electric and gas pasta cookers, electric and gas compartment steamers (both pressure and atmospheric) and electric and gas cheesemelters.

[FG] LIMIT CONTROL. A device responsive to changes in pressure, temperature or level for turning on, shutting off or throttling the gas supply to an *appliance*.

LIMITED CHARGE SYSTEM. A system in which, with the compressor idle, the design pressure will not be exceeded when the refrigerant charge has completely evaporated.

[A] LISTED. *Equipment*, materials, products or services included in a list published by an organization acceptable to the code official and concerned with evaluation of products or services that maintains periodic inspection of production of *listed equipment* or materials or periodic evaluation of services and whose listing states either that the *equipment*, material, product or service meets identified standards or has been tested and found suitable for a specified purpose.

LIVING SPACE. Space within a *dwelling unit* utilized for living, sleeping, eating, cooking, bathing, washing and sanitation purposes.

[W] LOCAL EXHAUST. An exhaust system that uses one or more fans to exhaust air from a specific room or rooms within a residential dwelling or sleeping unit.

LOWER EXPLOSIVE LIMIT (LEL). See *LFL*.

[F] LOWER FLAMMABLE LIMIT (LFL). The minimum concentration of vapor in air at which propagation of flame will occur in the presence of an ignition source. The LFL is sometimes referred to as LEL or lower explosive limit.

LOWER FLAMMABLE LIMIT (REFRIGERANT) (LFL). The minimum concentration of refrigerant that is capable of propagating a flame through a homogeneous mixture of refrigerant and air.

LOW-PRESSURE HOT-WATER-HEATING BOILER. A boiler furnishing hot water at pressures not exceeding 160 psi (1103 kPa) and at temperatures not exceeding 250°F (121°C).

LOW-PRESSURE STEAM-HEATING BOILER. A boiler furnishing steam at pressures not exceeding 15 psi (103 kPa).

LOW-PROBABILITY PUMP. A pump that is designed to prevent atmospheric release of the pumped fluid by one of the following methods:

1. The pump is permanently sealed.
2. The pump incorporates a static seal.
3. The pump incorporates not less than two sequential dynamic shaft seals to isolate the pumped fluid from atmosphere at shaft penetrations and automatically shuts down upon failure of any seal.

LOW-PROBABILITY SYSTEMS. A refrigeration system in which the basic design or the location of components is such that a leakage of refrigerant from a failed connection, seal or component will not enter an occupancy-classified area, other than the *machinery room*.

LOW-SIDE PRESSURE. The parts of a refrigerating system subject to evaporator pressure.

MACHINERY ROOM. An enclosed space that is required by Chapter 11 to contain refrigeration *equipment* and to comply with Sections 1105 and 1106.

MECHANICAL DRAFT SYSTEM. A venting system designed to remove flue or vent gases by mechanical means, that consists of an induced-draft portion under nonpositive static pressure or a forced-draft portion under positive static pressure.

Forced-draft venting system. A portion of a venting system using a fan or other mechanical means to cause the removal of flue or vent gases under positive static pressure.

Induced-draft venting system. A portion of a venting system using a fan or other mechanical means to cause the removal of flue or vent gases under nonpositive static vent pressure.

Power venting system. A portion of a venting system using a fan or other mechanical means to cause the removal of flue or vent gases under positive static vent pressure.

MECHANICAL EQUIPMENT/APPLIANCE ROOM. A room or space in which nonfuel-fired mechanical *equipment* and *appliances* are located.

MECHANICAL EXHAUST SYSTEM. A system for removing air from a room or space by mechanical means.

MECHANICAL JOINT.

1. A connection between pipes, fittings, or pipes and fittings that is not welded, brazed, caulked, soldered, solvent cemented or heat fused.
2. A general form of gas- or liquid-tight connections obtained by the joining of parts through a positive holding mechanical construction such as, but not limited to, flanged, screwed, clamped or flared connections.

MECHANICAL SYSTEM. A system specifically addressed and regulated in this code and composed of components, devices, *appliances* and *equipment*.

MEDIUM-DUTY COOKING APPLIANCE. Medium-duty cooking *appliances* include electric discrete element ranges (with or without oven), electric and gas hot-top ranges, electric and gas griddles, electric and gas double-sided griddles, electric and gas fryers (including open deep fat fryers, donut fryers, kettle fryers and pressure fryers), electric and gas conveyor pizza ovens, electric and gas tilting skillets (braising pans) and electric and gas rotisseries.

MODULAR BOILER. A steam or hot-water-heating assembly consisting of a group of individual boilers called modules intended to be installed as a unit without intervening stop valves. Modules are under one jacket or are individually jacketed. The individual modules shall be limited to a maximum input rating of 400,000 Btu/h (117 228 W) gas, 3 gallons per hour (gph) (11.4 L/h) oil, or 115 kW (electric).

NATURAL DRAFT SYSTEM. A venting system designed to remove flue or vent gases under nonpositive static vent pressure entirely by natural draft.

NATURAL VENTILATION. The movement of air into and out of a space through intentionally provided openings, such as windows and doors, or through nonpowered ventilators.

NET OCCUPIABLE FLOOR AREA. The floor area of an *occupiable space* defined by the inside surfaces of its walls but excluding shafts, column enclosures and other permanently enclosed, inaccessible and unoccupiable areas. Obstructions in the space such as furnishings, display or storage racks and other obstructions, whether temporary or permanent, shall not be deducted from the space area.

NO-FLOW CONDITION (SOLAR). A condition where thermal energy is not transferred from a solar thermal collector by means of flow of a heat transfer fluid.

NONABRASIVE/ABRASIVE MATERIALS. Nonabrasive particulate in high concentrations, moderately abrasive particulate in low and moderate concentrations, and highly abrasive particulate in low concentrations, such as alfalfa, asphalt, plaster, gypsum and salt.

NONCOMBUSTIBLE MATERIALS. Materials that, when tested in accordance with ASTM E136, have not fewer than three of four specimens tested meeting all of the following criteria:

1. The recorded temperature of the surface and interior thermocouples shall not at any time during the test rise more than 54°F (30°C) above the furnace temperature at the beginning of the test.
2. There shall not be flaming from the specimen after the first 30 seconds.
3. If the weight loss of the specimen during testing exceeds 50 percent, the recorded temperature of the surface and interior thermocouples shall not at any time during the test rise above the furnace air temperature at the beginning of the test, and there shall not be flaming of the specimen.

NONFOOD-GRADE FLUID. Any fluid that is not designated as a food-grade fluid.

[W] NOT BALANCED WHOLE HOUSE VENTILATION. A whole house ventilation system serving a dwelling or sleeping unit that is not considered balanced in accordance with the definition in this code for *balanced whole house ventilation system*. Only other than Group R-2 dwelling and sleeping units are allowed in accordance with Section 403.4.4.1 to have not *balanced whole house ventilation systems*.

[W] NOT DISTRIBUTED WHOLE HOUSE VENTILATION. A whole house ventilation system shall be considered not distributed when either the supply system or the exhaust system is not distributed. Supply systems are not distributed when a habitable space is supplied with outdoor air to ventilate an *interior adjacent room* or an interior adjoining space. Exhaust

DEFINITIONS

systems are not distributed when all bathrooms and kitchens are not exhausted by the whole house ventilation system. If either the supply system or the exhaust system is not distributed, then the ventilation quality adjustment system coefficient adjustment is required in accordance with Section C403.4.3.

[A] **OCCUPANCY.** The purpose for which a building, or portion thereof, is utilized or occupied.

OCCUPATIONAL EXPOSURE LIMIT (OEL). The time-weighted average (TWA) concentration for a normal 8-hour workday and a 40-hour workweek to which nearly all workers can be repeatedly exposed without adverse effect, based on the OSHA PEL, ACGIH TLV-TWA, TERA OARS WEEL, or consistent value.

OCCUPIABLE SPACE. An enclosed space intended for human activities, excluding those spaces intended primarily for other purposes, such as storage rooms and *equipment* rooms, that are only intended to be occupied occasionally and for short periods of time.

OFFSET (VENT). A combination of *approved* bends that make two changes in direction bringing one section of the vent out of line but into a line parallel with the other section.

OUTDOOR AIR. Air taken from the outdoors, and therefore not previously circulated through the system.

OUTDOOR OPENING. A door, window, louver or skylight openable to the outdoor atmosphere.

OUTLET. A threaded connection or bolted flange in a piping system to which a gas-burning *appliance* is attached.

PANEL HEATING. A method of radiant space heating in which heat is supplied by large heated areas of room surfaces. The heating element usually consists of warm water piping, warm air ducts, or electrical resistance elements embedded in or located behind ceiling, wall or floor surfaces.

PELLET FUEL-BURNING APPLIANCE. A closed-combustion, vented *appliance* equipped with a fuel-feed mechanism for burning processed pellets of solid fuel of a specified size and composition.

[W] PERMANENT CONSTRUCTION. Construction that, if removed, would disturb the structural integrity of the building or the fire resistance rating of a building assembly.

[S] PERSON. Any individual, receiver, administrator, executor, assignee, trustee in bankruptcy, trust, estate, firm, partnership, joint venture, club, company, joint stock company, business trust, municipal corporation, political subdivision of the State of Washington, corporation, limited liability company, association, society or any group of individuals acting as a unit, whether mutual, cooperative, fraternal, nonprofit or otherwise, and the United States or any instrumentality thereof.

PIPING. Where used in this code, “piping” refers to either pipe or tubing, or both.

Pipe. A rigid conduit of iron, steel, copper, copper-alloy, or plastic.

Tubing. Semirigid conduit of copper, copper-alloy, aluminum, plastic or steel.

PLASTIC, THERMOPLASTIC. A plastic that is capable of being repeatedly softened by increase of temperature and hardened by decrease of temperature.

PLASTIC, THERMOSETTING. A plastic that is capable of being changed into a substantially infusible or insoluble product when cured under application of heat or chemical means.

PLENUM. An enclosed portion of the building structure, other than an *occupiable space* being conditioned, that is designed to allow air movement, and thereby serve as part of an air distribution system.

POLLUTION-CONTROL UNIT (PCU). Manufactured *equipment* that is installed in a grease exhaust duct system for the purpose of extracting smoke, grease particles and odors from the exhaust flow by means of a series of filters.

PORTABLE FUEL CELL APPLIANCE. A fuel cell generator of electricity that is not fixed in place. A portable fuel cell *appliance* utilizes a cord and plug connection to a grid-isolated load and has an integral fuel supply.

[S] (~~POWER BOILER. See Boiler.~~)

[A] **PREMISES.** A lot, plot or parcel of land, including any structure thereon.

PRESS-CONNECT JOINT. A permanent mechanical joint incorporating an elastomeric seal or an elastomeric seal and corrosion-resistant grip or bite ring. The joint is made with a pressing tool and jaw or ring approved by the fitting manufacturer.

PRESSURE, FIELD TEST. A test performed in the field to prove system tightness.

PRESSURE RELIEF DEVICE. A pressure-actuated valve or rupture member designed to relieve excessive pressure automatically.

PRESSURE RELIEF VALVE. A pressure-actuated valve held closed by a spring or other means and designed to relieve pressure automatically in excess of the device’s setting.

[S] (~~PRESSURE VESSELS. Closed containers, tanks or vessels that are designed to contain liquids or gases, or both, under pressure.~~)

PRESSURE VESSELS—REFRIGERANT. Any refrigerant-containing receptacle in a refrigerating system. This does not include evaporators where each separate section does not exceed 0.5 cubic foot (0.014 m³) of refrigerant-containing volume, regardless of the maximum inside dimensions, evaporator coils, controls, headers, pumps and piping.

PRESSURE-LIMITING DEVICE. A pressure-responsive mechanism designed to stop automatically the operation of the pressure-imposing element at a predetermined pressure.

[S] PRODUCT-CONVEYING. Conveying solid particulates, such as refuse, dust, fumes and smoke; liquid particulate matter, such as spray residue, mists and fogs; vapors, such as vapors from flammable or corrosive liquids; noxious and toxic gases; and air at temperatures exceeding 250°F (121°C). Examples include, but are not limited to, combustion engine, industrial vacuum system, chemical booth, paint booth, paint enclosure and photo lab exhaust.

PROTECTIVE ASSEMBLY (REDUCED CLEARANCE). Any noncombustible assembly that is *labeled* or constructed in accordance with Table 308.4.2 and is placed between combustible materials or assemblies and mechanical *appliances*, devices or *equipment*, for the purpose of reducing required airspace *clearances*. Protective assemblies attached directly to a combustible assembly shall not be considered as part of that combustible assembly.

PURGE. To clear of air, water or other foreign substances.

PUSH-FIT JOINTS. A type of mechanical joint consisting of elastomeric seals and corrosion-resistant tube grippers. Such joints are permanent or removable, depending on the design.

QUICK-OPENING VALVE. A valve that opens completely by fast action, either manually or automatically controlled. A valve requiring one-quarter round turn or less is considered to be quick opening.

RADIANT HEATER. A heater designed to transfer heat primarily by direct radiation.

READY ACCESS (TO). That which enables a device, *appliance* or *equipment* to be directly reached, without requiring the removal or movement of any panel or similar obstruction [see *Access (to)*].

RECEIVER, LIQUID. A vessel permanently connected to a refrigeration system by inlet and outlet pipes for storage of liquid refrigerant.

RECIRCULATED AIR. Air removed from a conditioned space and intended for reuse as supply air.

RECLAIMED REFRIGERANTS. Refrigerants reprocessed to the same specifications as for new refrigerants by means including distillation. Such refrigerants have been chemically analyzed to verify that the specifications have been met. Reclaiming usually implies the use of processes or procedures that are available only at a reprocessing or manufacturing facility.

RECOVERED REFRIGERANTS. Refrigerants removed from a system in any condition without necessarily testing or processing them.

RECYCLED REFRIGERANTS. Refrigerants from which contaminants have been reduced by oil separation, removal of noncondensable gases, and single or multiple passes through devices that reduce moisture, acidity and particulate matter, such as replaceable core filter driers. These procedures usually are performed at the field job site or in a local service shop.

REFRIGERANT. A substance utilized to produce refrigeration by its expansion or vaporization.

REFRIGERANT SAFETY GROUP CLASSIFICATION. The alphabetical/numerical designation that indicates both the toxicity and flammability classifications of refrigerants.

Flammability. See *Flammability classification (Refrigerant)*.

Toxicity. See *Toxicity classification (Refrigerant)*.

REFRIGERATING SYSTEM. A combination of interconnected refrigerant-containing parts constituting one closed refrigerant circuit in which a refrigerant is circulated for the purpose of extracting heat.

REFRIGERATION CAPACITY RATING. Expressed as 1 horsepower (0.75 kW), 1 ton or 12,000 Btu/h (3.5 kW), shall all mean the same quantity.

REFRIGERATION MACHINERY ROOM. See *Machinery room*.

REFRIGERATION SYSTEM, ABSORPTION. A heat-operated, closed-refrigeration cycle in which a secondary fluid (the absorbent) absorbs a primary fluid (the refrigerant) that has been vaporized in the evaporator.

Direct system. A system in which the evaporator is in direct contact with the material or space refrigerated, or is located in air-circulating passages communicating with such spaces.

Indirect system. A system in which a brine coil cooled by the refrigerant is circulated to the material or space refrigerated, or is utilized to cool the air so circulated. Indirect systems are distinguished by the type or method of application.

REFRIGERATION SYSTEM, MECHANICAL. A combination of interconnected refrigeration-containing parts constituting one closed refrigerant circuit in which a refrigerant is circulated for the purpose of extracting heat and in which a compressor is used for compressing the refrigerant vapor.

DEFINITIONS

REFRIGERATION SYSTEM, SELF-CONTAINED. A complete factory-assembled and tested system that is shipped in one or more sections and that does not have refrigerant-containing parts that are joined in the field by other than companion or block valves.

REFRIGERATION SYSTEM CLASSIFICATION. Refrigeration systems are classified according to the degree of probability that leaked refrigerant from a failed connection, seal or component will enter an occupied area. The distinction is based on the basic design or location of the components.

[A] REGISTERED DESIGN PROFESSIONAL. An individual who is registered or licensed to practice their respective design profession as defined by the statutory requirements of the professional registration laws of the state or jurisdiction in which the project is to be constructed.

[W] RELIEF AIR. Exhausted return air from a system that provides ventilation for human usage.

[W] REPLACEMENT AIR. Outdoor air that is used to replace air removed from a building through an exhaust system. Replacement air may be derived from one or more of the following: Makeup air, supply air, transfer air, and infiltration. However, the ultimate source of all replacement air is outdoor air. When replacement air exceeds exhaust, the result is exfiltration.

RETURN AIR. Air removed from an *approved* conditioned space or location and recirculated or exhausted.

RETURN AIR SYSTEM. An assembly of connected ducts, *plenums*, fittings, registers and grilles through which air from the space or spaces to be heated or cooled is conducted back to the supply unit (see also *Supply air system*).

[FG] ROOM HEATER, VENTED. A free-standing heating unit burning solid or liquid fuel for direct heating of the space in and adjacent to that in which the unit is located.

SAFETY VALVE. A valve that relieves pressure in a steam boiler by opening fully at the rated discharge pressure. The valve is of the spring-pop type.

SELF-CONTAINED EQUIPMENT. Complete, factory-assembled and tested, heating, air-conditioning or refrigeration *equipment* installed as a single unit, and having all working parts, complete with motive power, in an enclosed unit of said machinery.

[BF] SHAFT. An enclosed space extending through one or more stories of a building, connecting vertical openings in successive floors, or floors and the roof.

[BF] SHAFT ENCLOSURE. The walls or construction forming the boundaries of a shaft.

[A] SLEEPING UNIT. A room or space in which people sleep, which can also include permanent provisions for living, eating, and either sanitation or kitchen facilities but not both. Such rooms and spaces that are also part of a *dwelling unit* are not *sleeping units*.

[BF] SMOKE DAMPER. A *listed* device installed in ducts and air transfer openings designed to resist the passage of smoke. The device is installed to operate automatically, controlled by a smoke detection system, and where required, is capable of being positioned from a fire command center.

[BF] SMOKE-DEVELOPED INDEX. A numerical value assigned to a material tested in accordance with ASTM E84.

SOLAR THERMAL SYSTEM. A system that converts solar radiation to thermal energy for use in heating or cooling.

SOLID FUEL (COOKING APPLICATIONS). Applicable to commercial food service operations only, solid fuel is any bulk material such as hardwood, mesquite, charcoal or briquettes that is combusted to produce heat for cooking operations.

SOURCE CAPTURE SYSTEM. A mechanical exhaust system designed and constructed to capture air contaminants at their source and to exhaust such contaminants to the outdoor atmosphere.

[FG] STATIONARY FUEL CELL POWER PLANT. A self-contained package or factory-matched packages that constitute an automatically operated assembly of integrated systems for generating useful electrical energy and recoverable thermal energy that is permanently connected and fixed in place.

[S] (~~STEAM HEATING BOILER.~~ A boiler operated at pressures not exceeding 15 psi (103 kPa) for steam.)

STOP VALVE. A shutoff valve for controlling the flow of liquid or gases.

[BG] STORY. That portion of a building included between the upper surface of a floor and the upper surface of the floor next above, except that the topmost story shall be that portion of a building included between the upper surface of the topmost floor and the ceiling or roof above.

STRENGTH, ULTIMATE. The highest stress level that the component will tolerate without rupture.

SUPPLY AIR. That air delivered to each or any space supplied by the air distribution system or the total air delivered to all spaces supplied by the air distribution system, which is provided for ventilating, heating, cooling, humidification, dehumidification and other similar purposes.

SUPPLY AIR SYSTEM. An assembly of connected ducts, *plenums*, fittings, registers and grilles through which air, heated or cooled, is conducted from the supply unit to the space or spaces to be heated or cooled (see also *Return air system*).

THEORETICAL AIR. The exact amount of air required to supply oxygen for complete *combustion* of a given quantity of a specific fuel.

THERMAL RESISTANCE (R). A measure of the ability to retard the flow of heat. The *R*-value is the reciprocal of thermal conductance.

[S] THIMBLE. A listed fitting designed to be installed in the opening in a masonry chimney through which the chimney connector passes.

[P] THIRD-PARTY CERTIFICATION AGENCY. An approved agency operating a product or material certification system that incorporates initial product testing, assessment and surveillance of a manufacturer's quality control system.

[P] THIRD-PARTY CERTIFIED. Certification obtained by the manufacturer indicating that the function and performance characteristics of a product or material have been determined by testing and ongoing surveillance by an approved third-party certification agency. Assertion of certification is in the form of identification in accordance with the requirements of the third-party certification agency.

[P] THIRD-PARTY TESTED. Procedure by which an approved testing laboratory provides documentation that a product, material or system conforms to specified requirements.

TLV-TWA (THRESHOLD LIMIT VALUE-TIME-WEIGHTED AVERAGE). The time-weighted average concentration of a refrigerant or other chemical in air for a normal 8-hour workday and a 40-hour workweek, to which nearly all workers are repeatedly exposed, day after day, without adverse effects, as adopted by the American Conference of Government Industrial Hygienists (ACGIH).

TOILET ROOM. A room containing a water closet and, frequently, a lavatory, but not a bathtub, shower, spa or similar bathing fixture.

TOXICITY CLASSIFICATION (REFRIGERANT). An alphabetical designation used to identify the toxicity of refrigerants. Class A indicates a refrigerant with low toxicity. Class B indicates a refrigerant with high toxicity.

TRANSITION FITTINGS, PLASTIC TO STEEL. An adapter for joining plastic pipe to steel pipe. The purpose of this fitting is to provide a permanent, pressure-tight connection between two materials that cannot be joined directly one to another.

[S] UNCONFINED SPACE. A space having a volume not less than 50 cubic feet per 1,000 Btu/h (4.8m³/kW) of the aggregate input rating of all fuel-burning appliances installed in that space. Rooms communicating directly with the space in which the appliances are installed, through openings not furnished with doors, are considered a part of the unconfined space.

[FG] UNIT HEATER. A self-contained *appliance* of the fan type, designed for the delivery of warm air directly into the space in which the *appliance* is located.

[S] UNSAFE. Constituting a fire or health hazard or otherwise dangerous to human life, constituting a hazard to safety, health or public welfare.

UNVENTED ALCOHOL FUEL-BURNING DECORATIVE APPLIANCE. A stationary, self-contained *appliance* intended to be directly or indirectly secured to a wall or floor and not intended for duct connection. Such *appliance* burns alcohol and is made in a manufacturing facility for subsequent delivery to the installation site.

VENT. A pipe or other conduit composed of factory-made components, containing a passageway for conveying *combustion* products and air to the atmosphere, *listed* and *labeled* for use with a specific type or class of *appliance*.

Pellet vent. A vent *listed* and *labeled* for use with *listed* pellet-fuel-burning *appliances*.

Type L vent. A vent *listed* and *labeled* for use with the following:

1. Oil-burning *appliances* that are *listed* for use with Type L vents.
2. Gas-fired *appliances* that are *listed* for use with Type B vents.

VENT CONNECTOR. The pipe that connects an *approved* fuel-fired *appliance* to a vent.

VENT DAMPER DEVICE, AUTOMATIC. A device intended for installation in the venting system, in the outlet of an individual automatically operated fuel-burning *appliance* that is designed to open the venting system automatically when the *appliance* is in operation and to close off the venting system automatically when the *appliance* is in a standby or shutdown condition.

VENTILATION. The natural or mechanical process of supplying conditioned or unconditioned air to, or removing such air from, any space.

VENTILATION AIR. That portion of supply air that comes from the outside (outdoors), plus any recirculated air that has been treated to maintain the desired quality of air within a designated space.

DEFINITIONS

[W] VENTILATION ZONE. Any indoor area that requires ventilation and comprises one or more spaces with the same occupancy category (see Table 403.3.1.1), occupant density, zone air distribution effectiveness (see Section 403.3.1.1.2), and design zone primary airflow per unit area.

[FG] VENTING SYSTEM. A continuous open passageway from the flue collar of an *appliance* to the outdoor atmosphere for the purpose of removing flue or vent gases. A venting system is usually composed of a vent or a *chimney* and vent connector, if used, assembled to form the open passageway.

[S] WATER HEATER. Any listed heating *appliance* or *equipment* that heats potable water and supplies such water to the potable hot water distribution system ((-)) excluding any *appliance* or *equipment* that exceeds any of the following:

1. An operating temperature of 210 degrees F (99 degrees C);
2. A maximum allowable working pressure of 160 pounds per square inch (1103 kPa);
3. A volume of 120 gallons (454 L); or
4. A heat input of 200,000 Btu/hr (58.6 kW).

Any *appliance* or *equipment* that exceeds any one of these values is classified as a boiler.

[W] WHOLE HOUSE VENTILATION SYSTEM. A mechanical ventilation system, including fans, controls, and ducts, which replaces by direct means, air from the habitable rooms with outdoor air.

ZONE. One *occupiable space* or several occupiable spaces with similar *occupancy* classification (see Table 403.3.1.1), occupant density, zone air distribution effectiveness and zone primary airflow rate per unit area.

CHAPTER 3

GENERAL REGULATIONS

User note:

About this chapter: Chapter 3 contains broadly applicable requirements that are necessarily placed in an overarching “general” chapter. These general requirements would not be suitably located in any other chapter that is specific to unique subject matter. General requirements include those related to installation, access, location, testing, structural and clearances.

SECTION 301 GENERAL

[S] **301.1 Scope.** This chapter shall govern the approval and installation of all *equipment* and *appliances* that comprise parts of the building mechanical systems regulated by this code in accordance with Section ~~(401.2)~~ 103.1.

Note: Seattle Energy Code Section C403.1.4 restricts the use of electric resistance and fossil fuel-fired equipment for HVAC heating in most buildings, and Section C404.2.1 restricts the use of electric resistance and fossil fuel-fired service water heating equipment in Group R-1 and R-2 buildings.

301.2 Energy utilization. Heating, ventilating and air-conditioning systems of all structures shall be designed and installed for efficient utilization of energy in accordance with the *International Energy Conservation Code*.

301.3 Identification. Each length of pipe and tubing and each pipe fitting utilized in a mechanical system shall bear the identification of the manufacturer.

301.4 Plastic pipe, fittings and components. Plastic pipe, fittings and components shall be *third-party certified* as conforming to NSF 14.

301.5 Third-party testing and certification. Piping, tubing and fittings shall comply with the applicable referenced standards, specifications and performance criteria of this code and shall be identified in accordance with Section 301.3. Piping, tubing and fittings shall either be tested by an approved third-party testing agency or certified by an approved *third-party certification agency*.

301.6 Fuel gas appliances and equipment. The approval and installation of fuel gas distribution piping and *equipment*, fuel gas-fired *appliances* and fuel gas-fired *appliance* venting systems shall be in accordance with the *International Fuel Gas Code*.

[S] **301.7 Listed and labeled.** *Appliances* regulated by this code shall be *listed* and *labeled* for the application in which they are installed and used, unless otherwise *approved* in accordance with Section 105 or 106.

Exception: Listing and labeling of *equipment* and *appliances* used for refrigeration shall be in accordance with Section 1101.2.

301.8 Labeling. Labeling shall be in accordance with the procedures set forth in Sections 301.8.1 through 301.8.2.3.

301.8.1 Testing. An *approved* agency shall test a representative sample of the mechanical *equipment* and *appliances* being *labeled* to the relevant standard or standards. The *approved* agency shall maintain a record of all of the tests performed. The record shall provide sufficient detail to verify compliance with the test standard.

301.8.2 Inspection and identification. The *approved* agency shall periodically perform an inspection, which shall be in-plant if necessary, of the mechanical *equipment* and *appliances* to be *labeled*. The inspection shall verify that the *labeled* mechanical *equipment* and *appliances* are representative of the mechanical *equipment* and *appliances* tested.

301.8.2.1 Independent. The agency to be *approved* shall be objective and competent. To confirm its objectivity, the agency shall disclose all possible conflicts of interest.

301.8.2.2 Equipment. An *approved* agency shall have adequate *equipment* to perform all required tests. The *equipment* shall be periodically calibrated.

301.8.2.3 Personnel. An *approved* agency shall employ experienced personnel educated in conducting, supervising and evaluating tests.

301.9 Label information. A permanent factory-applied nameplate(s) shall be affixed to *appliances* on which shall appear in legible lettering, the manufacturer’s name or trademark, the model number, serial number and the seal or mark of the *approved* agency. A label shall include the following:

GENERAL REGULATIONS

1. Electrical *equipment* and *appliances*: Electrical rating in volts, amperes and motor phase; identification of individual electrical components in volts, amperes or watts, motor phase; Btu/h (W) output; and required clearances.
2. Absorption units: Hourly rating in Btu/h (W); minimum hourly rating for units having step or automatic modulating controls; type of fuel; type of refrigerant; cooling capacity in Btu/h (W); and required clearances.
3. Fuel-burning units: Hourly rating in Btu/h (W); type of fuel *approved* for use with the *appliance*; and required clearances.
4. Electric comfort heating *appliances*: electric rating in volts, amperes and phase; Btu/h (W) output rating; individual marking for each electrical component in amperes or watts, volts and phase; and required *clearances* from combustibles.

[S] **301.10 Electrical.** Electrical wiring, controls and connections to *equipment* and *appliances* regulated by this code shall be in accordance with ((NFPA-70)) the *Seattle Electrical Code*.

[S] **301.11 Plumbing connections.** Potable water supply and building drainage system connections to *equipment* and *appliances* regulated by this code shall be in accordance with the ((~~International~~)) *Uniform Plumbing Code*.

301.12 Fuel types. Fuel-fired *appliances* shall be designed for use with the type of fuel to which they will be connected and the altitude at which they are installed. *Appliances* that comprise parts of the building mechanical system shall not be converted for the usage of a different fuel, except where *approved* and converted in accordance with the manufacturer's instructions. The fuel input rate shall not be increased or decreased beyond the limit rating for the altitude at which the *appliance* is installed.

301.13 Vibration isolation. Where vibration isolation of *equipment* and *appliances* is employed, an *approved* means of supplemental restraint shall be used to accomplish the support and restraint.

301.14 Repair. Defective material or parts shall be replaced or repaired in such a manner so as to preserve the original approval or listing.

301.15 Wind resistance. Mechanical *equipment*, *appliances* and supports that are exposed to wind shall be designed and installed to resist the wind pressures determined in accordance with the *International Building Code*.

[BS] **301.16 Flood hazard.** For structures located in flood hazard areas, mechanical systems, equipment and *appliances* shall be located at or above the elevation required by Section 1612 of the *International Building Code* for utilities and attendant *equipment*.

Exception: Mechanical systems, *equipment* and *appliances* are permitted to be located below the elevation required by Section 1612 of the of the *International Building Code* for utilities and attendant equipment provided that they are designed and installed to prevent water from entering or accumulating within the components and to resist hydrostatic and hydrodynamic loads and stresses, including the effects of buoyancy, during the occurrence of flooding up to such elevation.

[BS] **301.16.1 Coastal high-hazard areas and coastal A zones.** In coastal high-hazard areas and coastal A zones, mechanical systems and *equipment* shall not be mounted on or penetrate walls intended to break away under flood loads.

301.17 Rodentproofing. Buildings or structures and the walls enclosing habitable or occupiable rooms and spaces in which persons live, sleep or work, or in which feed, food or foodstuffs are stored, prepared, processed, served or sold, shall be constructed to protect against the entrance of rodents in accordance with the *International Building Code*.

301.18 Seismic resistance. Where earthquake loads are applicable in accordance with the *International Building Code*, mechanical system supports, anchorage and bracing shall be designed and installed for seismic forces in accordance with Chapter 16 of the *International Building Code*.

SECTION 302 PROTECTION OF STRUCTURE

302.1 Structural safety. The building or structure shall not be weakened by the installation of mechanical systems. Where floors, walls, ceilings or any other portion of the building or structure are required to be altered or replaced in the process of installing or repairing any system, the building or structure shall be left in a safe structural condition in accordance with the *International Building Code*.

302.2 Penetrations of floor/ceiling assemblies and fire-resistance-rated assemblies. Penetrations of floor/ceiling assemblies and assemblies required to have a fire-resistance rating shall be protected in accordance with Chapter 7 of the *International Building Code*.

[BS] **302.3 Cutting, notching and boring in wood framing.** The cutting, notching and boring of wood framing members shall comply with Sections 302.3.1 through 302.3.4.

[BS] **302.3.1 Joist notching.** Notches on the ends of joists shall not exceed one-fourth the joist depth. Holes bored in joists shall not be within 2 inches (51 mm) of the top or bottom of the joist, and the diameter of any such hole shall not exceed

GENERAL REGULATIONS

with the exterior door air leakage requirements of the *International Energy Conservation Code* and equipped with an *approved* self-closing device.

303.4 Protection from damage. *Appliances* shall not be installed in a location where subject to mechanical damage unless protected by *approved* barriers.

303.5 Indoor locations. Furnaces and boilers installed in closets and alcoves shall be listed for such installation.

303.6 Outdoor locations. *Appliances* installed in other than indoor locations shall be *listed* and *labeled* for outdoor installation.

[S] **303.7 Pit locations.** *Appliances* installed in pits or excavations shall not come in direct contact with the surrounding soil and shall be installed not less than 3 inches (76 mm) above the pit floor. The sides of the pit or excavation shall be held back not less than 12 inches (305 mm) from the *appliance*, and a minimum of 30 inches (762 mm) on the control side. Where the depth exceeds 12 inches (305 mm) below adjoining grade, the walls of the pit or excavation shall be lined with concrete or masonry. Such concrete or masonry shall extend not less than 4 inches (102 mm) above adjoining grade and shall have sufficient lateral load-bearing capacity to resist collapse. Excavation on the control side of the *appliance* shall extend not less than 30 inches (762 mm) horizontally. The *appliance* shall be protected from flooding in an *approved* manner.

[S][BF] **303.8 (~~Elevator shafts~~) Temperature control and installation of pipes or ducts conveying gases, vapors or liquids in hoistways, machine rooms, control rooms or machinery spaces for elevators.** (~~Mechanical systems shall not be located in an elevator shaft.~~) Temperature control in machine rooms, control rooms and machinery spaces for elevators shall be provided per Seattle Building Code Section 3020.7. Pipes and ducts conveying gases, vapors or liquids shall not be installed in elevator hoistways, elevator machine rooms, control rooms and elevator machinery spaces unless allowed per Seattle Building Code Section 3022.2.

Exceptions:

1. Only ducts for heating, cooling, ventilating, and venting these spaces are permitted to be installed in the hoistway, machine room, and machinery space.
2. Ducts and electrical conduit may pass through an elevator machine room or machinery space if they are separated from the room or space by construction equal to the rated construction of the room or space and located so that all required clearances are maintained.

If a vented machine room is not vented directly to the outside of the building, the vent shall be enclosed within a fire barrier with at least a one-hour fire-resistance rating, or as required for a shaft where it passes through occupied floors.

3. Standard sprinkler protection conforming to the requirements of NFPA 13 is permitted to be installed in these spaces, subject to rules promulgated by the code official.
4. Subject to the approval of the code official, pipes that are protected with double containment whose joints are threaded, soldered or welded joints are permitted. Pipes shall not be located less than 7 feet above the floor in machine rooms.

303.9 Fireplaces in Group I-2, Condition 2 occupancies. Fuel-burning *appliances* and fireplaces in Group I-2, Condition 2 occupancies shall be in accordance with Section 901.4.

[S][BI] **303.10 Interior exit stairways and exit passageways.** Mechanical systems shall not be located in *interior exit stairways* and ramps and *exit passageways*. Penetrations into and openings through *interior exit stairways* and ramps and *exit passageways* are prohibited except for:

1. Equipment allowed or required by the International Building Code to serve the interior exit stairway and exit passageways such as:
 - 1.1. Ductwork and equipment necessary for independent ventilation or stairway pressurization.
 - 1.2. Sprinkler piping.
 - 1.3. Standpipes.
 - 1.4. Electrical raceway serving the interior exit stairway or ramp terminating in a steel box not exceeding 16 square inches (10 323 mm²) in area, and
 - 1.5. Piping used exclusively for the drainage of rainfall runoff from roof areas provided the roof is not used for a helistop or heliport.
2. Unfired heaters allowed by the International Building Code for freeze protection of fire protection equipment may penetrate one protective membrane. The conduit serving the heater may penetrate both protective membranes. Such penetrations shall be protected in accordance with International Building Code Section 714. There shall be no penetrations or communicating openings, whether protected or not, between adjacent interior exit stairways and ramps.

Exception: Membrane penetrations shall be permitted on the outside of the *interior exit stairway* and ramp. Such penetrations shall be protected in accordance with *International Building Code* Section 714.4.4.2.

Interpretation: Ducts passing through *interior exit stairways* shall be separated from the stairway by construction having a fire-resistance rating at least equal to the stairway walls. At least one side of the duct enclosure shall abut the *interior exit stairway enclosure*.

SECTION 304 INSTALLATION

304.1 General. *Equipment* and *appliances* shall be installed as required by the terms of their approval, in accordance with the conditions of the listing, the manufacturer's installation instructions and this code. Manufacturer's installation instructions shall be available on the job site at the time of inspection.

304.2 Conflicts. Where conflicts between this code and the conditions of listing or the manufacturer's installation instructions occur, the provisions of this code shall apply.

Exception: Where a code provision is less restrictive than the conditions of the listing of the *equipment* or *appliance* or the manufacturer's installation instructions, the conditions of the listing and the manufacturer's installation instructions shall apply.

304.3 Elevation of ignition source. *Equipment* and *appliances* having an *ignition source* and located in hazardous locations and public garages, private garages, repair garages, automotive motor fuel-dispensing facilities and parking garages shall be elevated such that the source of ignition is not less than 18 inches (457 mm) above the floor surface on which the *equipment* or *appliance* rests. For the purpose of this section, rooms or spaces that are not part of the living space of a *dwelling unit* and that communicate directly with a private garage through openings shall be considered to be part of the private garage.

Exception: Elevation of the ignition source is not required for *appliances* that are listed as flammable vapor ignition resistant.

[S] 304.3.1 Parking garages. Connection of a parking garage with any room in which there is a fuel-fired *appliance* shall be by means of a vestibule providing a two-doorway separation, except that a single door is permitted where the sources of ignition in the *appliance* are elevated in accordance with Section 304.3.

Exception: This section shall not apply to *appliance* installations complying with Section 304.6 or to *equipment* having an internal combustion engine.

304.4 Prohibited equipment and appliance location. *Equipment* and *appliances* having an *ignition source* shall not be installed in Group H *occupancies* or control areas where open use, handling or dispensing of combustible, flammable or explosive materials occurs.

[FG] 304.5 Hydrogen-generating and refueling operations. Hydrogen-generating and refueling *appliances* shall be installed and located in accordance with their listing and the manufacturer's instructions. Ventilation shall be required in accordance with Section 304.5.1, 304.5.2 or 304.5.3 in public garages, private garages, repair garages, automotive motor fuel-dispensing facilities and parking garages that contain hydrogen-generating *appliances* or refueling systems. For the purpose of this section, rooms or spaces that are not part of the living space of a *dwelling unit* and that communicate directly with a private garage through openings shall be considered to be part of the private garage.

[FG] 304.5.1 Natural ventilation. Indoor locations intended for hydrogen-generating or refueling operations shall be limited to a maximum floor area of 850 square feet (79 m²) and shall communicate with the outdoors in accordance with Sections 304.5.1.1 and 304.5.1.2. The maximum rated output capacity of hydrogen-generating *appliances* shall not exceed 4 standard cubic feet per minute (0.00189 m³/s) of hydrogen for each 250 square feet (23 m²) of floor area in such spaces. The minimum cross-sectional dimension of air openings shall be 3 inches (76 mm). Where ducts are used, they shall be of the same cross-sectional area as the free area of the openings to which they connect. In such locations, *equipment* and *appliances* having an *ignition source* shall be located such that the source of ignition is not within 12 inches (305 mm) of the ceiling.

[FG] 304.5.1.1 Two openings. Two permanent openings shall be provided within the garage. The upper opening shall be located entirely within 12 inches (305 mm) of the ceiling of the garage. The lower opening shall be located entirely within 12 inches (305 mm) of the floor of the garage. Both openings shall be provided in the same exterior wall. The openings shall communicate directly with the outdoors and shall have a minimum free area of 1/2 square foot per 1,000 cubic feet (1 m²/610 m³) of garage volume.

[FG] 304.5.1.2 Louvers and grilles. In calculating free area required by Section 304.5.1, the required size of openings shall be based on the net free area of each opening. If the free area through a design of louver or grille is known, it shall be used in calculating the size opening required to provide the free area specified. If the design and free area are not

GENERAL REGULATIONS

known, it shall be assumed that wood louvers will have 25-percent free area and metal louvers and grilles will have 75-percent free area. Louvers and grilles shall be fixed in the open position.

[FG] 304.5.2 Mechanical ventilation. Indoor locations intended for hydrogen-generating or refueling operations shall be ventilated in accordance with Section 502.16. In such locations, *equipment* and *appliances* having an *ignition source* shall be located such that the source of ignition is below the mechanical ventilation outlet(s).

[FG] 304.5.3 Specially engineered installations. As an alternative to the provisions of Sections 304.5.1 and 304.5.2, the necessary supply of air for ventilation and dilution of flammable gases shall be provided by an *approved* engineered system.

304.6 Public garages. *Appliances* located in public garages, motor fuel-dispensing facilities, repair garages or other areas frequented by motor vehicles, shall be installed not less than 8 feet (2438 mm) above the floor. Where motor vehicles are capable of passing under an *appliance*, the *appliance* shall be installed at the *clearances* required by the *appliance* manufacturer and not less than 1 foot (305 mm) higher than the tallest vehicle garage door opening.

Exception: The requirements of this section shall not apply where the *appliances* are protected from motor vehicle impact and installed in accordance with Section 304.3 and NFPA 30A.

304.7 Private garages. *Appliances* located in private garages and carports shall be installed with a minimum clearance of 6 feet (1829 mm) above the floor.

Exception: The requirements of this section shall not apply where the *appliances* are protected from motor vehicle impact and installed in accordance with Section 304.3.

304.8 Construction and protection. Boiler rooms and furnace rooms shall be protected as required by the *International Building Code*.

304.9 Clearances to combustible construction. Heat-producing *equipment* and *appliances* shall be installed to maintain the required *clearances* to combustible construction as specified in the listing and manufacturer's instructions. Such *clearances* shall be reduced only in accordance with Section 308. *Clearances* to combustibles shall include such considerations as door swing, drawer pull, overhead projections or shelving and window swing, shutters, coverings and drapes. Devices such as door-stops or limits, closers, drapery ties or guards shall not be used to provide the required *clearances*.

304.10 Clearances from grade. *Equipment* and *appliances* installed at grade level shall be supported on a level concrete slab or other *approved* material extending not less than 3 inches (76 mm) above adjoining grade or shall be suspended not less than 6 inches (152 mm) above adjoining grade. Such support shall be in accordance with the manufacturer's installation instructions.

[BE] 304.11 Guards. Guards shall be provided where various components that require service and roof hatch openings are located within 10 feet (3048 mm) of a roof edge or open side of a walking surface and such edge or open side is located more than 30 inches (762 mm) above the floor, roof, or grade below. The guard shall extend not less than 30 inches (762 mm) beyond each end of components that require service and each end of the roof hatch parallel to the roof edge. The top of the guard shall be located not less than 42 inches (1067 mm) above the elevated surface adjacent to the guard. The guard shall be constructed so as to prevent the passage of a 21-inch-diameter (533 mm) sphere and shall comply with the loading requirements for guards specified in the *International Building Code*.

Exception: Guards are not required where fall arrest/restraint anchorage connector devices that comply with ANSI/ASSP Z359.1 are installed.

304.12 Area served. *Appliances* serving different areas of a building other than where they are installed shall be permanently marked in an *approved* manner that uniquely identifies the *appliance* and the area it serves.

[SI] 304.13 Clearances and encroachments in the public right-of-way. All encroachments of *equipment* and *appliances* on, over or under sidewalks, streets, alleys and other public places are subject to approval by the Director of Transportation and the *code official*. Encroachments shall comply with this code and other codes as determined by the Director of Transportation and the *code official*.

<p>Note: The Seattle Department of Transportation (SDOT) publishes the "Seattle Right-of-Way Improvements Manual" that contains detailed information on <i>clearances</i> (subsection 3.3, Clearances), and required SDOT street use permits (Chapter 4). SDOT discourages encroachments into the public right-of-way by mechanical <i>equipment</i>.</p>
--

SECTION 305 PIPING SUPPORT

305.1 General. Mechanical system piping shall be supported in accordance with this section.

GENERAL REGULATIONS

306.3 Appliances in attics. Attics containing *appliances* shall be provided with an opening and unobstructed passageway large enough to allow removal of the largest *appliance*. The passageway shall be not less than 30 inches (762 mm) high and 22 inches (559 mm) wide and not more than 20 feet (6096 mm) in length measured along the centerline of the passageway from the opening to the *appliance*. The passageway shall have continuous solid flooring not less than 24 inches (610 mm) wide. A level service space not less than 30 inches (762 mm) deep and 30 inches (762 mm) wide shall be present at the front or service side of the *appliance*. The clear access opening dimensions shall be not less than 20 inches by 30 inches (508 mm by 762 mm), and large enough to allow removal of the largest *appliance*.

Exceptions:

1. The passageway and level service space are not required where the *appliance* is capable of being serviced and removed through the required opening.
2. Where the passageway is unobstructed and not less than 6 feet (1829 mm) high and 22 inches (559 mm) wide for its entire length, the passageway shall be not greater than 50 feet (15 250 mm) in length.

[S] 306.3.1 Electrical requirements. A luminaire controlled by a switch located at the required passageway opening and a receptacle outlet shall be provided at or near the *appliance* location in accordance with ((NFPA-70)) the Seattle Electrical Code.

306.4 Appliances under floors. Underfloor spaces containing *appliances* shall be provided with an access opening and unobstructed passageway large enough to remove the largest *appliance*. The passageway shall be not less than 30 inches (762 mm) high and 22 inches (559 mm) wide, nor more than 20 feet (6096 mm) in length measured along the centerline of the passageway from the opening to the *appliance*. A level service space not less than 30 inches (762 mm) deep and 30 inches (762 mm) wide shall be present at the front or service side of the *appliance*. If the depth of the passageway or the service space exceeds 12 inches (305 mm) below the adjoining grade, the walls of the passageway shall be lined with concrete or masonry. Such concrete or masonry shall extend not less than 4 inches (102 mm) above the adjoining grade and shall have sufficient lateral-bearing capacity to resist collapse. The clear access opening dimensions shall be not less than 22 inches by 30 inches (559 mm by 762 mm), and large enough to allow removal of the largest *appliance*.

Exceptions:

1. The passageway is not required where the level service space is present when the access is open and the *appliance* is capable of being serviced and removed through the required opening.
2. Where the passageway is unobstructed and not less than 6 feet high (1929 mm) and 22 inches (559 mm) wide for its entire length, the passageway shall not be limited in length.

[S] 306.4.1 Electrical requirements. A luminaire controlled by a switch located at the required passageway opening and a receptacle outlet shall be provided at or near the *appliance* location in accordance with ((NFPA-70)) the Seattle Electrical Code.

[W][S] 306.5 Equipment and appliances on roofs or elevated structures. Where *equipment* or *appliances* requiring access ((or *appliances*)) are located on an elevated structure or the roof of a building such that personnel will have to climb higher than 16 feet (4877 mm) above grade to access such *equipment* or *appliances*, an interior or exterior means of access shall be provided. Such access shall not require climbing over obstructions greater than 30 inches (762 mm) in height or walking on roofs having a slope greater than 4 units vertical in 12 units horizontal (33-percent slope). Such access shall not require the use of portable ladders. Where access involves climbing over parapet walls, the height shall be measured to the top of the parapet wall.

Permanent ladders installed to provide the required access shall comply with the following minimum design criteria:

1. The side railing shall extend above the parapet or roof edge not less than ((30)) 42 inches (((762)) 1067 mm).
2. Ladders shall have rung spacing not to exceed ((44)) 12 inches (((356)) 305 mm) on center. The uppermost rung shall be ((not greater than)) a maximum of 24 inches (610 mm) below the upper edge of the roof hatch, roof or parapet, as applicable.
3. Ladders shall have a toe spacing not less than ((6)) 7 inches (((152)) 178 mm) deep.
4. There shall be not less than 18 inches (457 mm) between rails.
5. Rungs shall have a diameter not less than 0.75-inch (19.1 mm) and be capable of withstanding a 300-pound (136 kg) load.
6. Ladders over 30 feet (9144 mm) in height shall be provided with offset sections and landings capable of withstanding 100 pounds per square foot (488 kg/m²). Landing dimensions shall be not less than 18 inches (457 mm) and not less than the width of the ladder served. A guard rail shall be provided on all open sides of the landing.
7. Climbing clearance. The distance from the centerline of the rungs to the nearest permanent object on the climbing side of the ladder shall be not less than 30 inches (762 mm) measured perpendicular to the rungs. This distance shall be maintained from the point of ladder access to the bottom of the roof hatch. A minimum clear width of 15 inches (381

mm) shall be provided on both sides of the ladder measured from the midpoint of and parallel with the rungs except where cages or wells are installed.

8. Landing required. The ladder shall be provided with a clear and unobstructed bottom landing area having a minimum dimension of 30 inches (762 mm) by 30 inches (762 mm) centered in front of the ladder.
9. Ladders shall be protected against corrosion by *approved* means.
10. Access to ladders shall be provided at all times.

Catwalks installed to provide the required access shall be not less than 24 inches (610 mm) wide and shall have railings as required for service platforms.

Exception: This section shall not apply to Group R-3 *occupancies*.

Interpretation I306.5: Item 10 allows access to ladders to be restricted to authorized personnel and prohibits storage that blocks or restricts access to the ladder.

306.5.1 Sloped roofs. Where *appliances, equipment, fans* or other components that require service are installed on a roof having a slope of 3 units vertical in 12 units horizontal (25-percent slope) or greater and having an edge more than 30 inches (762 mm) above grade at such edge, a level platform shall be provided on each side of the *appliance* or *equipment* to which access is required for service, repair or maintenance. The platform shall be not less than 30 inches (762 mm) in any dimension and shall be provided with guards. The guards shall extend not less than 42 inches (1067 mm) above the platform, shall be constructed so as to prevent the passage of a 21-inch-diameter (533 mm) sphere and shall comply with the loading requirements for guards specified in the *International Building Code*. Access shall not require walking on roofs having a slope greater than 4 units vertical in 12 units horizontal (33-percent slope). Where access involves obstructions greater than 30 inches (762 mm) in height, such obstructions shall be provided with ladders installed in accordance with Section 306.5 or stairways installed in accordance with the requirements specified in the *International Building Code* in the path of travel to and from *appliances, fans* or *equipment* requiring service.

[S] **306.5.2 Electrical requirements.** A receptacle outlet shall be provided at or near the *equipment* location in accordance with ((NFPA 70)) *the Seattle Electrical Code*.

[W] **306.6 Appliances above ceilings.** Appliances that are located above ceilings shall have ready access for inspection, service and repair without removing permanent construction. Appliances that are located above a ceiling shall be provided with access to the working space(s) by an opening not smaller than 22 inches by 22 inches (559 mm by 559 mm). All enclosure doors or hinged panels shall be capable of opening a minimum of 90 degrees.

The appliance is not required to be removable or replaceable through the enclosure door, hinged panel, removable lay-in ceiling tile, or other removable covers. The appliance may be removed or replaced by removing the ceiling or wall assemblies adjacent to the appliance as long as they are not permanent construction.

Exceptions:

1. This section shall not apply to replacement appliances installed in existing compartments and alcoves where the working space clearances are in accordance with the appliance manufacturer's installation instructions.
2. A smaller enclosure door, hinged panel, removable lay-in ceiling tile, or other removable covers shall be permitted when allowed by the appliance manufacturer's installation instructions and electrical access is not required.

SECTION 307 CONDENSATE DISPOSAL

[S] **307.1 Fuel-burning appliances.** Liquid *combustion* by-products of condensing *appliances* shall be collected, pH neutralized and discharged to an *approved* plumbing fixture or disposal area in accordance with the manufacturer's installation instructions. Condensate piping shall be of *approved* corrosion-resistant material and shall not be smaller than the drain connection on the *appliance*. Such piping shall maintain a minimum horizontal slope in the direction of discharge of not less than 1/8 unit vertical in 12 units horizontal (1-percent slope).

307.1.1 Identification. The termination of concealed condensate piping shall be marked to indicate whether the piping is connected to the primary or secondary drain.

307.2 Evaporators and cooling coils. Condensate drain systems shall be provided for *equipment* and *appliances* containing evaporators or cooling coils. Condensate drain systems shall be designed, constructed and installed in accordance with Sections 307.2.1 through 307.2.5.

Exception: Evaporators and cooling coils that are designed to operate in sensible cooling only and not support condensation shall not be required to meet the requirements of this section.

GENERAL REGULATIONS

307.2.1 Condensate disposal. Condensate from all cooling coils and evaporators shall be conveyed from the drain pan outlet to an *approved* place of disposal. Such piping shall maintain a minimum horizontal slope in the direction of discharge of not less than 1/8 unit vertical in 12 units horizontal (1-percent slope). Condensate shall not discharge into a street, alley or other areas so as to cause a nuisance.

[S] 307.2.1.1 Condensate discharge. Condensate drains shall not directly connect to any plumbing drain, waste or vent pipe. Condensate drains shall not discharge into a plumbing fixture other than a floor sink, floor drain, ~~((trench drain,))~~ mop sink, hub drain, standpipe, utility sink or laundry sink or other approved locations in accordance with the Seattle Plumbing Code. Condensate drain connections to a lavatory wye branch tailpiece or to a bathtub overflow pipe shall not be considered as discharging to a plumbing fixture. Except where discharging to grade outdoors, the point of discharge of condensate drains shall be located within, or controlled by, the same occupancy, tenant space or *dwelling unit* as the source of the condensate.

[S] 307.2.2 Drain pipe materials and sizes. Components of the condensate disposal system shall be ABS, cast iron, copper and copper alloy, CPVC, cross-linked polyethylene, galvanized steel, PE-RT, polyethylene, polypropylene, PVC or PVDF pipe or tubing. Components shall be selected for the pressure and temperature rating of the installation. Joints and connections shall be made in accordance with the applicable provisions of ~~((Chapter 7 of))~~ the ~~((International))~~ Uniform Plumbing Code relative to the material type. Condensate waste and drain line size shall be not less than 3/4-inch pipe size and shall not decrease in size from the drain pan connection to the place of condensate disposal. Where the drain pipes from more than one unit are manifolded together for condensate drainage, the pipe or tubing shall be sized in accordance with Table 307.2.2.

**TABLE 307.2.2
CONDENSATE DRAIN SIZING**

EQUIPMENT CAPACITY	MINIMUM CONDENSATE PIPE DIAMETER
Up to 20 tons of refrigeration	3/4 inch
Over 20 tons to 40 tons of refrigeration	1 inch
Over 40 tons to 90 tons of refrigeration	1-1/4 inch
Over 90 tons to 125 tons of refrigeration	1-1/2 inch
Over 125 tons to 250 tons of refrigeration	2 inch

For SI: 1 inch = 25.4 mm, 1 ton = 3.517 kW.

[W] 307.2.3 Auxiliary and secondary drain systems. In addition to the requirements of Section 307.2.1, where damage to any building components could occur as a result of overflow from the *equipment* primary condensate removal system, one of the following auxiliary protection methods shall be provided for each cooling coil or fuel-fired *appliance* that produces condensate:

1. An auxiliary drain pan with a separate drain shall be provided under the coils on which condensation will occur. The auxiliary pan drain shall discharge to a conspicuous point of disposal to alert occupants in the event of a stoppage of the primary drain. The pan shall have a minimum depth of 1-1/2 inches (38 mm), shall be not less than 3 inches (76 mm) larger than the unit, or the coil dimensions in width and length and shall be constructed of corrosion-resistant material. Galvanized sheet steel pans shall have a minimum thickness of not less than 0.0236 inch (0.6010 mm) (No. 24 gage). Nonmetallic pans shall have a minimum thickness of not less than 0.0625 inch (1.6 mm).
2. A separate overflow drain line shall be connected to the drain pan provided with the *equipment*. Such overflow drain shall discharge to a conspicuous point of disposal to alert occupants in the event of a stoppage of the primary drain. The overflow drain line shall connect to the drain pan at a higher level than the primary drain connection.
3. An auxiliary drain pan without a separate drain line shall be provided under the coils on which condensate will occur. Such pan shall be equipped with a water-level detection device conforming to UL 508 that will shut off the *equipment* served prior to overflow of the pan. The auxiliary drain pan shall be constructed in accordance with Item 1 of this section.
4. A water-level detection device conforming to UL 508 shall be provided that will shut off the *equipment* served in the event that the primary drain is blocked. The device shall be installed in the primary drain line, the overflow drain line, or in the equipment-supplied drain pan, located at a point higher than the primary drain line connection and below the overflow rim of such pan.

Exceptions:

1. Fuel-fired *appliances* that automatically shut down operation in the event of a stoppage in the condensate drainage system.
2. Unducted fan coil units where there is no factory option available for water-level detection devices and which are installed directly within the occupied space.

[S] **307.2.3.1 Water-level monitoring devices.** On down-flow units and all other coils that do not have a secondary drain or provisions to install a secondary or auxiliary drain pan, a water-level monitoring device shall be installed inside the primary drain pan. This device shall shut off the *equipment* served in the event that the primary drain becomes restricted. Devices installed in the drain line shall not be permitted.

Exception: Water-level monitoring devices are not required for unducted fan coil units where there is no factory option available for water-level detection devices and the units are installed directly within the occupied space.

307.2.3.2 Appliance, equipment and insulation in pans. Where *appliances, equipment* or insulation are subject to water damage when auxiliary drain pans fill, that portion of the *appliance, equipment* and insulation shall be installed above the rim of the pan. Supports located inside of the pan to support the *appliance* or *equipment* shall be water resistant and *approved*.

307.2.3.3 Identification. The termination of concealed condensate piping shall be marked to indicate whether the piping is connected to the primary or secondary drain.

307.2.4 Traps. Condensate drains shall be trapped as required by the *equipment* or *appliance* manufacturer.

[W] **307.2.4.1 Ductless mini-split system traps.** Ductless mini-split *equipment* that produces condensate shall be provided with an inline check valve located in the drain line, ~~((or))~~ a trap, or other means of condensate drainage in accordance with the manufacturer's instructions.

307.2.5 Drain line maintenance. Condensate drain lines shall be configured to permit the clearing of blockages and performance of maintenance without requiring the drain line to be cut.

307.3 Condensate pumps. Condensate pumps located in uninhabitable spaces, such as attics and crawl spaces, shall be connected to the *appliance* or *equipment* served such that when the pump fails, the *appliance* or *equipment* will be prevented from operating. Pumps shall be installed in accordance with the manufacturer's instructions.

SECTION 308 CLEARANCE REDUCTION

308.1 Scope. This section shall govern the reduction in required *clearances* to combustible materials and combustible assemblies for *chimneys, vents, kitchen exhaust equipment, mechanical appliances, and mechanical devices and equipment*.

308.2 Listed appliances and equipment. The reduction of the required *clearances* to combustibles for *listed and labeled appliances and equipment* shall be in accordance with the requirements of this section except that such *clearances* shall not be reduced where reduction is specifically prohibited by the terms of the *appliance* or *equipment* listing.

308.3 Protective assembly construction and installation. Reduced *clearance* protective assemblies, including structural and support elements, shall be constructed of noncombustible materials. Spacers utilized to maintain an airspace between the protective assembly and the protected material or assembly shall be noncombustible. Where a space between the protective assembly and protected combustible material or assembly is specified, the same space shall be provided around the edges of the protective assembly and the spacers shall be placed so as to allow air circulation by convection in such space. Protective assemblies shall not be placed less than 1 inch (25 mm) from the mechanical *appliances, devices or equipment, regardless of the allowable reduced clearance.*

308.4 Allowable reduction. The reduction of required *clearances* to combustible assemblies or combustible materials shall be based on the utilization of a reduced *clearance* protective assembly in accordance with Section 308.4.1 or 308.4.2.

308.4.1 Labeled assemblies. The allowable *clearance* reduction shall be based on an approved reduced *clearance* protective assembly that is *listed and labeled* in accordance with UL 1618.

308.4.2 Reduction table. The allowable *clearance* reduction shall be based on one of the methods specified in Table 308.4.2. Where required *clearances* are not listed in Table 308.4.2, the reduced *clearances* shall be determined by linear interpolation between the distances listed in the table. Reduced *clearances* shall not be derived by extrapolation below the range of the table.

308.4.2.1 Solid fuel-burning appliances. The *clearance* reduction methods specified in Table 308.4.2 shall not be utilized to reduce the *clearance* required for solid fuel-burning *appliances* that are *labeled* for installation with *clearances* of 12 inches (305 mm) or less. Where *appliances* are *labeled* for installation with *clearances* of greater than 12 inches (305 mm), the *clearance* reduction methods of Table 308.4.2 shall not reduce the *clearance* to less than 12 inches (305 mm).

308.4.2.2 Masonry chimneys. The *clearance* reduction methods specified in Table 308.4.2 shall not be utilized to reduce the *clearances* required for masonry *chimneys* as specified in Chapter 8 and the *International Building Code*.

308.4.2.3 Chimney connector pass-throughs. The *clearance* reduction methods specified in Table 308.4.2 shall not be utilized to reduce the *clearances* required for *chimney* connector pass-throughs as specified in Section 803.10.4.

GENERAL REGULATIONS

308.4.2.4 Masonry fireplaces. The *clearance* reduction methods specified in Table 308.4.2 shall not be utilized to reduce the *clearances* required for masonry fireplaces as specified in Chapter 8 and the *International Building Code*.

308.4.2.5 Kitchen exhaust ducts. The *clearance* reduction methods specified in Table 308.4.2 shall not be utilized to reduce the minimum *clearances* required by Section 506.3.11.1 for kitchen exhaust ducts enclosed in a shaft.

**TABLE 308.4.2
CLEARANCE REDUCTION METHODS^b**

TYPE OF PROTECTIVE ASSEMBLY ^a	REDUCED CLEARANCE WITH PROTECTION (inches) ^a							
	Horizontal combustible assemblies located above the heat source				Horizontal combustible assemblies located beneath the heat source and all vertical combustible assemblies			
	Required clearance to combustibles without protection (inches) ^a				Required clearance to combustibles without protection (inches)			
	36	18	9	6	36	18	9	6
Galvanized sheet steel, having a minimum thickness of 0.0236 inch (No. 24 gage), mounted on 1-inch glass fiber or mineral wool batt reinforced with wire on the back, 1 inch off the combustible assembly	18	9	5	3	12	6	3	3
Galvanized sheet steel, having a minimum thickness of 0.0236 inch (No. 24 gage), spaced 1 inch off the combustible assembly	18	9	5	3	12	6	3	2
Two layers of galvanized sheet steel, having a minimum thickness of 0.0236 inch (No. 24 gage), having a 1-inch airspace between layers, spaced 1 inch off the combustible assembly	18	9	5	3	12	6	3	3
Two layers of galvanized sheet steel, having a minimum thickness of 0.0236 inch (No. 24 gage), having 1 inch of fiberglass insulation between layers, spaced 1 inch off the combustible assembly	18	9	5	3	12	6	3	3
0.5-inch inorganic insulating board, over 1 inch of fiberglass or mineral wool batt, against the combustible assembly	24	12	6	4	18	9	5	3
3-1/2-inch brick wall, spaced 1 inch off the combustible wall	—	—	—	—	12	6	6	6
3-1/2-inch brick wall, against the combustible wall	—	—	—	—	24	12	6	5

For SI: 1 inch = 25.4 mm, °C = [(°F) – 32]/1.8, 1 pound per cubic foot = 16.02 kg/m³, 1.0 Btu • in/(ft² • h • °F) = 0.144 W/m² • K.

- a. Mineral wool and glass fiber batts (blanket or board) shall have a minimum density of 8 pounds per cubic foot and a minimum melting point of 1,500°F. Insulation material utilized as part of a clearance reduction system shall have a thermal conductivity of 1.0 Btu • in/(ft² • h • °F) or less. Insulation board shall be formed of noncombustible material.
- b. For limitations on clearance reduction for solid fuel-burning appliances, masonry chimneys, connector pass-throughs, masonry fireplaces and kitchen ducts, see Sections 308.4.2.1 through 308.4.2.5.

**SECTION 309
TEMPERATURE CONTROL**

[S][BG] 309.1 Space-heating systems. Interior spaces intended for human occupancy shall be provided with active or passive space-heating systems capable of maintaining an average indoor temperature of not less than 68°F (20°C) at a point 3 feet (914 mm) above floor (~~on the design heating day~~) when the outside temperature is 24°F. The installation of portable space heaters shall not be used to achieve compliance with this section.

Exceptions:

1. Interior spaces where the primary purpose is not associated with human comfort.
2. Group F, H, S and U *occupancies*.

**SECTION 310
EXPLOSION CONTROL**

[F] 310.1 Required. Structures occupied for purposes involving explosion hazards shall be provided with explosion control where required by the *International Fire Code*. Explosion control systems shall be designed and installed in accordance with Section 911 of the *International Fire Code*.

**SECTION 311
SMOKE AND HEAT VENTS**

[F] **311.1 Required.** *Approved* smoke and heat vents shall be installed in the roofs of one-story buildings where required by the *International Fire Code*. Smoke and heat vents shall be designed and installed in accordance with the *International Fire Code*.

**SECTION 312
HEATING AND COOLING LOAD CALCULATIONS**

[S] **312.1 Load calculations.** Heating and cooling system design loads for the purpose of sizing systems, *appliances* and *equipment* shall be determined in accordance with the procedures described in the ((~~ASHRAE/ACCA Standard 183~~)) *International Energy Conservation Code*. ((~~Alternatively, design loads shall be determined by an approved equivalent computation procedure, using the design parameters specified in Chapter 3 [CE] of the *International Energy Conservation Code*.~~))

CHAPTER 4

VENTILATION

User note:

About this chapter: Chapter 4 intends to provide an indoor atmosphere that protects the health and well-being of building occupants. Both mechanical and natural ventilation are addressed. Mechanical ventilation provides what is considered to be acceptable indoor air quality. Mechanical ventilation minimizes adverse health effects and provides an atmosphere that generally is not objectionable to occupants.

SECTION 401 GENERAL

401.1 Scope. This chapter shall govern the ventilation of spaces within a building intended to be occupied. Mechanical exhaust systems, including exhaust systems serving clothes dryers and cooking *appliances*; hazardous exhaust systems; dust, stock and refuse conveyor systems; subslab soil exhaust systems; smoke control systems; energy recovery ventilation systems and other systems specified in Section 502 shall comply with Chapter 5.

[W][S] 401.2 Ventilation required. Every occupied space other than enclosed parking garages, loading docks and motor vehicle repair garages shall be ventilated by in accordance with Section 401.2.1, 401.2.2, or 401.2.3. Enclosed parking garages, loading docks and motor vehicle repair garages shall be ventilated by mechanical means in accordance with Sections 403 and 404.

401.2.1 Group R occupancies. Ventilation in Group R occupancies shall be provided in accordance with Section 403.4.

Note: The *Seattle Energy Code* requires that balanced ventilation be provided in Group R-2 dwelling and sleeping units.

401.2.2 Ambulatory care facilities and Group I-2 occupancies. Ambulatory care facilities and Group I-2 occupancies shall be ventilated by mechanical means in accordance with Section 407.

401.2.3 All other occupancies. Ventilation in all other occupancies shall be provided natural means in accordance with Section 402 or by mechanical means in accordance with Section 403. (~~*Dwelling units* complying with the air leakage requirements of the *International Energy Conservation Code* or ASHRAE 90.1 shall be ventilated by mechanical means in accordance with Section 403. Ambulatory care facilities and Group I-2 occupancies shall be ventilated by mechanical means in accordance with Section 407.~~)

[W] 401.3 When required. Group R *occupancies* shall be vented continuously or intermittently in accordance with Section 403.4. Ventilation in all other *occupancies* shall be provided during the periods that the room or space is occupied.

[W][S] 401.4 Intake opening location. Air intake openings shall comply with all of the following:

1. Intake openings shall be located not less than 10 feet (3048 mm) from lot lines or buildings on the same lot. Where openings front on a street or public way, the distance shall be measured from the opposite side of the street or public way.
2. Mechanical and gravity outdoor air intake openings shall be located not less than 10 feet (3048 mm) horizontally from any hazardous or noxious contaminant source, such as vents, streets, alleys, parking lots and loading docks, except as specified in Item 3 or Section 501.3.1. Outdoor air intake openings shall be permitted to be located less than 10 feet (3048 mm) horizontally from streets, alleys, parking garage entries, parking lots and loading docks provided that the openings are located not less than 25 feet (7620 mm) vertically above such locations. Where openings front on a street or public way, the distance shall be measured from the closest edge of the street or public way.

Exceptions:

1. Intake air openings providing less than 500 cfm of outdoor air to Group R occupancies are permitted to be located less than 10 feet (3048 mm) horizontally from parking lots provided that the openings are not less than 15 feet (4572 mm) vertically above the parking lot.
2. Intake air openings providing less than 500 cfm of outdoor air to Group R occupancies are permitted to be located less than 10 feet (3048 mm) horizontally from parking lots provided that the openings are not less than 15 feet (4572 mm) vertically above the clear height for vehicles in the parking garage.
3. Enclosed parking garage and repair garage intakes are permitted to be located less than 10 feet horizontally from the street, alley, parking lots and loading docks.

VENTILATION

3. Intake openings shall be located not less than 3 feet (914 mm) below contaminant sources where such sources are located within 10 feet (3048 mm) of the opening. Separation is not required between intake air openings and ~~(living space exhaust)~~ environmental air other than kitchen exhaust openings of an individual *dwelling unit* or *sleeping unit* where an approved factory-built intake/exhaust combination termination fitting is used to separate the air streams in accordance with the manufacturer’s instructions. For these combined terminations, the exhaust air concentration within the intake airflow shall not exceed 10 percent as established by the manufacturer, in accordance with ASHRAE 62.2 Section 6.8, exception 4.

Exceptions:

1. A minimum of 3 feet (914 mm) horizontal separation between other environmental air exhaust outlets and other dwelling or sleeping unit factory-built intake/exhaust combination termination fittings shall be maintained.
2. No separation is required between an energy recovery ventilation unit that provides exclusively whole house ventilation and serves only one dwelling unit or sleeping unit, and an operable opening of that same dwelling unit or sleeping unit.
4. Intake openings on structures in flood hazard areas shall be at or above the elevation required by Section 1612 of the *International Building Code* for utilities and attendant equipment.
5. Intake openings shall not be located:
 - 5.1. In a crawl space;
 - 5.2. Less than one foot (305 mm) above a roof, adjacent grade, or other surface directly below the intake; or
 - 5.3. Under a deck having a surface height less than three feet above grade or other surface directly below the intake.

Interpretation: For purposes of this section, lot line includes any property line separating one lot from another lot, but does not include any property line separating a lot from a public street or alley right-of-way.

401.5 Intake opening protection. Air intake openings that terminate outdoors shall be protected with corrosion-resistant screens, louvers or grilles. Openings in louvers, grilles and screens shall be sized in accordance with Table 401.5, and shall be protected against local weather conditions. Louvers that protect air intake openings in structures located in hurricane-prone regions, as defined in the *International Building Code*, shall comply with AMCA 550. Outdoor air intake openings located in exterior walls shall meet the provisions for exterior wall opening protectives in accordance with the *International Building Code*.

**TABLE 401.5
OPENING SIZES IN LOUVERS, GRILLES AND SCREENS PROTECTING AIR INTAKE OPENINGS**

OUTDOOR OPENING TYPE	MINIMUM AND MAXIMUM OPENING SIZES IN LOUVERS, GRILLES AND SCREENS ^a
Intake openings in residential occupancies	Not < 1/4 inch and not > 1/2 inch
Intake openings in other than residential occupancies	> 1/4 inch and not > 1 inch

For SI: 1 inch = 25.4 mm.

a. For rectangular openings, the table requirements apply to the shortest side. For round openings, the table requirements apply to the diameter. For square openings, the table requirements apply to any side.

401.6 Contaminant sources. Stationary local sources producing airborne particulates, heat, odors, fumes, spray, vapors, smoke or gases in such quantities as to be irritating or injurious to health shall be provided with an exhaust system in accordance with Chapter 5 or a means of collection and removal of the contaminants. Such exhaust shall discharge directly to an *approved* location at the exterior of the building.

[W] 401.7 Testing and balancing. At the discretion of the building official, flow testing may be required to verify that the mechanical system(s) satisfies the requirements of this chapter. Flow testing may be performed using flow hood measuring at the intake or exhaust points of the system, in-line pitot tube, or pitot-traverse type measurement systems in the duct, short-term tracer gas measurements, or other means approved by the code official.

[W][S] 401.8 Compliance and commissioning. Compliance with Sections 402 through 403.4 shall be demonstrated through engineering calculations. Documentation of calculations shall be submitted with the permit plan sets. Testing and commissioning shall be performed and documented in accordance with the *International Energy Conservation Code*.

SECTION 402 NATURAL VENTILATION

[S][BG] **402.1 Natural ventilation.** *Natural ventilation* of an occupied space shall be through windows, doors, louvers or other openings to the outdoors. The operating mechanism for such openings shall be provided with ready access so that the openings are readily controllable by the building occupants.

Exception: Automatically controlled *natural ventilation* systems do not require ready access and control by building occupants.

[BG] **402.2 Ventilation area required.** The minimum openable area to the outdoors shall be 4 percent of the floor area being ventilated.

[BG] **402.3 Adjoining spaces.** Where rooms and spaces without openings to the outdoors are ventilated through an adjoining room, the opening to the adjoining rooms shall be unobstructed and shall have an area not less than 8 percent of the floor area of the interior room or space, but not less than 25 square feet (2.3 m²). The minimum openable area to the outdoors shall be based on the total floor area being ventilated.

Exception: Exterior openings required for ventilation shall be permitted to open into a thermally isolated sunroom addition or patio cover, provided that the openable area between the sunroom addition or patio cover and the interior room has an area of not less than 8 percent of the floor area of the interior room or space, but not less than 20 square feet (1.86 m²). The minimum openable area to the outdoors shall be based on the total floor area being ventilated.

[BG] **402.4 Openings below grade.** Where openings below grade provide required *natural ventilation*, the outdoor horizontal clear space measured perpendicular to the opening shall be one and one-half times the depth of the opening. The depth of the opening shall be measured from the average adjoining ground level to the bottom of the opening.

SECTION 403 MECHANICAL VENTILATION

[W] **403.1 Ventilation system.** Mechanical ventilation shall be provided by a method of supply air and return or *exhaust air*. ~~((except that mechanical ventilation air requirements for Group R-2, R-3 and R-4 occupancies shall be provided by an exhaust system, supply system or combination thereof.))~~ The amount of supply air shall be approximately equal to the amount of return and *exhaust air*. The system shall not be prohibited from producing negative or positive pressure. The system to convey *ventilation air* shall be designed and installed in accordance with Chapter 6.

[W][S] **403.2 Outdoor air required.** The minimum outdoor ~~((air flow))~~ flow rate shall be determined in accordance with Section 403.3.

Exceptions:

1. Where the *registered design professional* demonstrates that an engineered ventilation system design will prevent the maximum concentration of contaminants from exceeding that obtainable by the rate of outdoor air ventilation determined in accordance with Section 403.3, the minimum required rate of outdoor air shall be reduced in accordance with such engineered system design.
2. Alternate systems designed in accordance with ASHRAE Standard 62.1 Section 6.2, Ventilation Rate Procedure, shall be permitted.

[W] **403.2.1 Recirculation of air.** The ~~((outdoor))~~ air required by Section 403.3 shall not be recirculated. Air in excess of that required by Section 403.3 shall not be prohibited from being recirculated as a component of supply air to building spaces, except that:

1. Ventilation air shall not be recirculated from one *dwelling* to another or to dissimilar *occupancies*.
2. Supply air to a swimming pool and associated deck areas shall not be recirculated unless such air is dehumidified to maintain the relative humidity of the area at 60 percent or less. Air from this area shall not be recirculated to other spaces where ~~((more than))~~ 10 percent or more of the resulting supply airstream consists of air recirculated from these spaces. The design and installation of dehumidification systems shall comply with ANSI/ACCA 10 Manual SPS.
3. Where mechanical exhaust is required by Note b in Table 403.3.1.1, recirculation of air from such spaces shall be prohibited. ~~((Recirculation of air that is contained completely within such spaces shall not be prohibited. Where recirculation of air is prohibited, all))~~ All air supplied to such spaces shall be exhausted, including any air in excess of that required by Table 403.3.1.1.

[W][S] 4. ~~((Where mechanical exhaust is required by Note g in Table 403.3.1.1, mechanical exhaust is required and recirculation from such spaces is prohibited where more than 10 percent of the resulting supply airstream consists of air recirculated from these spaces.))~~ Air used as transfer for heat removal may be circulated. Return air from such

VENTILATION

spaces shall only be permitted to be recirculated when returned to an energy recovery ventilation system complying with Section 514. Recirculation of air that is contained completely within such spaces shall not be prohibited.

403.2.2 Transfer air. Except where recirculation from such spaces is prohibited by Table 403.3.1.1, air transferred from occupiable spaces is not prohibited from serving as *makeup air* for required exhaust systems in such spaces as kitchens, baths, toilet rooms, elevators and smoking lounges. The amount of transfer air and *exhaust air* shall be sufficient to provide the flow rates as specified in Section 403.3.1.1. The required outdoor airflow rates specified in Table 403.3.1.1 shall be introduced directly into such spaces or into the occupied spaces from which air is transferred or a combination of both.

[W] 403.3 Outdoor air and local exhaust airflow rates. Group ~~((R-2, R-3 and R-4))~~ R occupancies ~~((three stories and less in height above grade plane))~~ shall be provided with outdoor air and local exhaust in accordance with Section ~~((403.3.2))~~ 403.4. ~~((Other))~~ All other buildings intended to be occupied shall be provided with outdoor air and local exhaust in accordance with Section 403.3.1.

403.3.1 Other buildings intended to be occupied. The design of local exhaust systems and ventilation systems for outdoor air for *occupancies* other than Group R-2, R-3 and R-4 three stories and less above grade plane shall comply with Sections 403.3.1.1 through 403.3.1.4.

[W] 403.3.1.1 Outdoor airflow rate. Ventilation systems shall be designed to have the capacity to supply the minimum outdoor airflow rate, determined in accordance with this section. In each occupiable space, the ventilation system shall be designed to deliver the required rate of outdoor airflow to the *breathing zone*. Outdoor air shall be supplied directly to each occupiable space from an air handling unit through a fully ducted path or ducted to within 12 inches of the return air opening of a fan-powered terminal unit used to transfer the outdoor air to the occupiable space.

The occupant load utilized for design of the ventilation system shall be not less than the number determined from the estimated maximum occupant load rate indicated in Table 403.3.1.1. Ventilation rates for occupancies not represented in Table 403.3.1.1 shall be those for a listed *occupancy* classification that is most similar in terms of occupant density, activities and building construction; or shall be determined by an *approved* engineering analysis. The ventilation system, including transfer fan-powered terminal units, shall be designed to supply the required rate of *ventilation air* continuously during the period the building is occupied, except as otherwise stated in other provisions of the code.

With the exception of smoking lounges, the ventilation rates in Table 403.3.1.1 are based on the absence of smoking in occupiable spaces. Where smoking is anticipated in a space other than a smoking lounge, the ventilation system serving the space shall be designed to provide ventilation over and above that required by Table 403.3.1.1 in accordance with accepted engineering practice.

Exception: ~~((The occupant load is not required to be determined based on the estimated maximum occupant load rate indicated in Table 403.3.1.1 where approved statistical data document the accuracy of an alternative anticipated occupant density.))~~ Where occupancy density is known and documented in the plans, the outside air rate may be based on the design occupant density. Under no circumstance shall the occupancies used result in outside air less than one-half that resulting from application of Table 403.3.1.1 estimated maximum occupancy rates.

**[W][S] TABLE 403.3.1.1
((MINIMUM VENTILATION RATES)) REQUIRED OUTDOOR VENTILATION AIR**

OCCUPANCY CLASSIFICATION	OCCUPANT DENSITY #/1000 FT ² ^a	PEOPLE OUTDOOR AIRFLOW RATE IN BREATHING ZONE, R _p CFM/PERSON	AREA OUTDOOR AIRFLOW RATE IN BREATHING ZONE, R _a CFM/FT ² ^a	EXHAUST AIRFLOW RATE CFM/FT ² ^a
Correctional facilities				
Booking/waiting	50	7.5	0.06	—
Cells				
without plumbing fixtures	25	5	0.12	—
[S] with plumbing fixtures ^{b, c}	25	5	0.12	1.0
Day room	30	5	0.06	—
Dining halls (see “Food and beverage service”)	—	—	—	—
Guard stations	15	5	0.06	—
Dry cleaners, laundries				
Coin-operated dry cleaner	20	15	—	—
Coin-operated laundries	20	7.5	0.12	—
Commercial dry cleaner	30	30	—	—
Commercial laundry	10	5	0.12	—
Storage, pick up	30	7.5	0.12	—

**[W][S] TABLE 403.3.1.1—continued
(MINIMUM VENTILATION RATES) REQUIRED OUTDOOR VENTILATION AIR**

OCCUPANCY CLASSIFICATION	OCCUPANT DENSITY #/1000 FT ² ^a	PEOPLE OUTDOOR AIRFLOW RATE IN BREATHING ZONE, R _p CFM/PERSON	AREA OUTDOOR AIRFLOW RATE IN BREATHING ZONE, R _a CFM/FT ² ^a	EXHAUST AIRFLOW RATE CFM/FT ² ^a
Education				
Art classroom ^g	20	10	0.18	0.7
Auditoriums	150	5	0.06	—
Classrooms (ages 5–8)	25	10	0.12	—
Classrooms (age 9 plus)	35	10	0.12	—
Computer lab	25	10	0.12	—
Corridors (see “Public spaces”)	—	—	—	—
Day care (through age 4)	25	10	0.18	—
Lecture classroom	65	7.5	0.06	—
Lecture hall (fixed seats)	150	7.5	0.06	—
[S] Locker/dressing rooms ^{g,o}	—	—	—	0.25
Media center	25	10	0.12	—
Multiuse assembly	100	7.5	0.06	—
Music/theater/dance	35	10	0.06	—
[S] Science laboratories ^{g,o}	25	10	0.18	1.0
[S] ((Smoking lounges ^b	70	60	—	—))
Sports locker rooms ^{g,o}	—	—	—	0.5
Wood/metal shops ^{g,o}	20	10	0.18	0.5
Food and beverage service				
Bars, cocktail lounges	100	7.5	0.18	—
Cafeteria, fast food	100	7.5	0.18	—
Dining rooms	70	7.5	0.18	—
Kitchens (cooking) ^b	20	7.5	0.12	0.7
Hotels, motels, resorts and dormitories				
[S] Bathrooms/toilet—private ^{g,o}	—	—	—	25/50 ^f
Bedroom/living room	10	5	0.06	—
Conference/meeting	50	5	0.06	—
Dormitory sleeping areas	20	5	0.06	—
Gambling casinos	120	7.5	0.18	—
Lobbies/prefunction	30	7.5	0.06	—
Multipurpose assembly	120	5	0.06	—
Offices				
Conference rooms	50	5	0.06	—
[W] Kitchenettes ^k	25	5	0.06	0.30
Main entry lobbies	10	5	0.06	—
Office spaces	5	5	0.06	—
Reception areas	30	5	0.06	—
Telephone/data entry	60	5	0.06	—
Private dwellings, single and multiple				
Garages, common for multiple units ^b	—	—	—	0.75
[W] Kitchens ^b	—	—	—	((50/100 ^f)) See Table 403.4.7
[W] Living areas ^c	Based on number of bedrooms. First bedroom, 2; each additional bedroom, 1	((0.35 ACH but not less than 15- cfm/person)) See Table 403.4.2	—	—
[W] Toilet rooms, and bathrooms ^{g,o}	—	—	—	((25/50 ^f)) See Table 403.4.7

VENTILATION

**[W][S] TABLE 403.3.1.1—continued
(MINIMUM VENTILATION RATES) REQUIRED OUTDOOR VENTILATION AIR**

OCCUPANCY CLASSIFICATION	OCCUPANT DENSITY #/1000 FT ² ^a	PEOPLE OUTDOOR AIRFLOW RATE IN BREATHING ZONE, R _p CFM/PERSON	AREA OUTDOOR AIRFLOW RATE IN BREATHING ZONE, R _a CFM/FT ² ^a	EXHAUST AIRFLOW RATE CFM/FT ² ^a
Public spaces				
[W] Corridors <u>servicing other than Group R occupancies</u>	—	—	0.06	—
[W] Corridors <u>servicing Group R dwelling or sleeping units with whole house exhaust system</u>	=	=	<u>0.12</u>	=
[W] Corridors <u>servicing Group R dwelling or sleeping units with other than whole house exhaust system</u>	=	=	<u>0.06</u>	=
Courtrooms	70	5	0.06	—
Elevator car	—	—	—	1.0
[W][S] Elevator lobbies in parking garages ^d	=	=	<u>1.0^e</u>	=
Legislative chambers	50	5	0.06	—
Libraries	10	5	0.12	—
Museums (children's)	40	7.5	0.12	—
Museums/galleries	40	7.5	0.06	—
Places of religious worship	120	5	0.06	—
Shower room (per shower head) ^g	—	—	—	50/20 ^f
[S] ((Smoking lounges ^b	70	60	—	—))
Toilet rooms — public ^g	—	—	—	50/70 ^e
Retail stores, sales floors and showroom floors				
Dressing rooms	—	—	—	0.25
Mall common areas	40	7.5	0.06	—
Sales	15	7.5	0.12	—
Shipping and receiving	2	10	0.12	—
[S] ((Smoking lounges ^b	70	60	—	—))
Storage rooms	—	—	0.12	—
Warehouses (see "Storage")	—	10	0.06	—
Specialty shops				
Automotive motor fuel-dispensing stations ^b	—	—	—	1.5
[S] Barber	25	((7.5) <u>20</u>)	0.06	0.5
Beauty salons ^b	25	20	0.12	0.6
Embalming room ^b	—	—	—	2.0
Nail salons ^{b, h}	25	20	0.12	0.6
Pet shops (animal areas) ^b	10	7.5	0.18	0.9
Supermarkets	8	7.5	0.06	—
Sports and amusement				
Bowling alleys (seating areas)	40	10	0.12	—
Disco/dance floors	100	20	0.06	—
Game arcades	20	7.5	0.18	—
[W] Gym, stadium, arena (play area) ⁱ	((7) =)	((20) =)	((0.18) <u>0.30</u>)	—
Health club/aerobics room	40	20	0.06	—
Health club/weight room	10	20	0.06	—
Ice arenas without combustion engines ⁱ	—	—	0.30	0.5
Spectator areas	150	7.5	0.06	—
Swimming pools (pool and deck area)	—	—	0.48	—

[W][S] TABLE 403.3.1.1—continued
((MINIMUM VENTILATION RATES)) REQUIRED OUTDOOR VENTILATION AIR

OCCUPANCY CLASSIFICATION	OCCUPANT DENSITY #/1000 FT ² ^a	PEOPLE OUTDOOR AIRFLOW RATE IN BREATHING ZONE, R _p CFM/PERSON	AREA OUTDOOR AIRFLOW RATE IN BREATHING ZONE, R _a CFM/FT ² ^a	EXHAUST AIRFLOW RATE CFM/FT ² ^a
Storage				
<u>[W]</u> Janitor closets, trash rooms, recycling rooms	=	=	=	<u>1.0</u>
[S] Refrigerated warehouses/freezers ^m	—	10	—	0.75
[W] Repair garages ^d ((enclosed parking garages^{b-d}))	—	—	—	0.75
<u>[S]</u> Enclosed loading docks ^d	=	=	=	<u>1.5</u>
<u>[S]</u> Enclosed parking garages ^d	=	=	=	<u>0.75</u>
<u>[S]</u> Ticket booths (within enclosed parking garages) ^l	<u>60</u>	=	=	=
<u>[W]</u> Storage rooms, chemical Warehouses	=	=	=	<u>1.5</u>
[S] Non-retail storage spaces >100 sf ^o	=	=	<u>0.06</u>	=
Theaters				
Auditoriums (see “Education”)	—	—	—	—
Lobbies	150	5	0.06	—
Stages, studios	70	10	0.06	—
Ticket booths	60	5	0.06	—
Transportation				
Platforms	100	7.5	0.06	—
Transportation waiting	100	7.5	0.06	—
Workrooms				
Bank vaults/safe deposit	5	5	0.06	—
Computer (without printing)	4	5	0.06	—
Copy, printing rooms	4	5	0.06	0.5
Darkrooms	—	—	—	1.0
<u>[W]</u> Freezer and refrigerated spaces (<50°F) ^m	<u>0</u>	<u>10</u>	<u>0</u>	<u>0</u>
Meat processing ^c	10	15	—	—
Pharmacy (prep. area)	10	5	0.18	—
Photo studios	10	5	0.12	—

For SI: 1 cubic foot per minute = 0.0004719 m³/s, 1 ton = 908 kg, 1 cubic foot per minute per square foot = 0.00508 m³/(s • m²), °C = [(°F) – 32]/1.8, 1 square foot = 0.0929 m².

- a. Based upon net occupiable floor area.
- b. Mechanical exhaust required and the recirculation of air from such spaces is prohibited. Recirculation of air that is contained completely within such spaces shall not be prohibited (see Section 403.2.1, Item 3).
- c. Spaces unheated or maintained below 50°F are not covered by these requirements unless the occupancy is continuous.
- d. Ventilation systems ((~~in enclosed parking garages~~)) shall comply with Section 404.
- e. Rates are per water closet or urinal. The higher rate shall be provided where the exhaust system is designed to operate intermittently. The lower rate shall be permitted only where the exhaust system is designed to operate continuously while occupied.
- f. Rates are per room unless otherwise indicated. The higher rate shall be provided where the exhaust system is designed to operate intermittently. The lower rate shall be permitted only where the exhaust system is designed to operate continuously while occupied.
- [W][S] g. Mechanical exhaust is required and recirculation from such spaces is prohibited. For occupancies other than science laboratories, where there is a wheel-type energy recovery ventilation (ERV) unit in the exhaust system design, the volume of air leaked from the exhaust airstream into the outdoor airstream within the ERV shall be less than 10 percent of the outdoor air volume. ((~~Recirculation~~)) Reconditioning of air that is contained completely within such spaces shall not be prohibited (see Section 403.2.1, Items 2 and 4).
- h. For nail salons, each manicure and pedicure station shall be provided with a source capture system capable of exhausting not less than 50 cfm per station. Exhaust inlets shall be located in accordance with Section 502.20. Where one or more required source capture systems operate continuously during occupancy, the exhaust rate from such systems shall be permitted to be applied to the exhaust flow rate required by Table 403.3.1.1 for the nail salon.
- [W] i. Reserved.
- [W] j. When combustion equipment is intended to be used on the playing surface, additional dilution ventilation and/or source control shall be provided.
- [W] k. Kitchenettes require exhaust when they contain a domestic cooking appliance range or oven that is installed in accordance with Table 507.1.2. Kitchenettes that only contain a microwave cooking appliance are not required to have exhaust. A kitchenette may not contain commercial cooking appliances that require Type I or Type II exhaust as these occupancies are required to be exhausted to the kitchen category in Table 403.3.1.1.
- [S] l. This space shall be maintained at a positive pressure.

VENTILATION

[S] m. For occupied freezer and refrigerated spaces utilize proposed occupant density for outdoor airflow rates.

[S] n. The required outdoor airflow rate shall be introduced directly into such spaces or into the occupied space from which the air is transferred or a combination of both.

[S] o. Transfer air permitted in accordance with Section 403.2.2. For non-retail storage areas, transfer air is also permitted from an adjacent open parking garage, or an enclosed parking garage or loading dock that is mechanically ventilated in accordance with Section 404.

403.3.1.1.1 Zone outdoor airflow. The minimum outdoor airflow required to be supplied to each zone shall be determined as a function of *occupancy* classification and space air distribution effectiveness in accordance with Sections 403.3.1.1.1.1 through 403.3.1.1.1.3.

403.3.1.1.1.1 Breathing zone outdoor airflow. The outdoor airflow rate required in the *breathing zone* (V_{bz}) of the *occupiable space* or spaces in a zone shall be determined in accordance with Equation 4-1.

$$V_{bz} = R_p P_z + R_a A_z \tag{Equation 4-1}$$

where:

A_z = Zone floor area: the net *occupiable floor area* of the space or spaces in the zone.

P_z = Zone population: the number of people in the space or spaces in the zone.

R_p = People outdoor air rate: the outdoor airflow rate required per person from Table 403.3.1.1.

R_a = Area outdoor air rate: the outdoor airflow rate required per unit area from Table 403.3.1.1.

403.3.1.1.1.2 Zone air distribution effectiveness. The zone air distribution effectiveness (E_z) shall be determined using Table 403.3.1.1.1.2.

**TABLE 403.3.1.1.2
ZONE AIR DISTRIBUTION EFFECTIVENESS^{a, b, c, d}**

AIR DISTRIBUTION CONFIGURATION	E_z
Ceiling or floor supply of cool air	1.0 ^e
Ceiling or floor supply of warm air and floor return	1.0
Ceiling supply of warm air and ceiling return	0.8 ^f
Floor supply of warm air and ceiling return	0.7
Makeup air drawn in on the opposite side of the room from the exhaust or return	0.8
Makeup air drawn in near to the exhaust or return location	0.5

For SI: 1 foot = 304.8 mm, 1 foot per minute = 0.00506 m/s, °C = [(°F) – 32]/1.8.

a. “Cool air” is air cooler than space temperature.

b. “Warm air” is air warmer than space temperature.

c. “Ceiling” includes any point above the breathing zone.

d. “Floor” includes any point below the breathing zone.

e. Zone air distribution effectiveness of 1.2 shall be permitted for systems with a floor supply of cool air and ceiling return, provided that low-velocity displacement ventilation achieves unidirectional flow and thermal stratification.

f. Zone air distribution effectiveness of 1.0 shall be permitted for systems with a ceiling supply of warm air, provided that supply air temperature is less than 15°F above space temperature and provided that the 150-foot-per-minute supply air jet reaches to within 4-1/2 feet of floor level.

403.3.1.1.1.3 Zone outdoor airflow. The zone outdoor airflow rate (V_{oz}), shall be determined in accordance with Equation 4-2.

$$V_{oz} = \frac{V_{bz}}{E_z} \tag{Equation 4-2}$$

403.3.1.1.2 System outdoor airflow. The outdoor air required to be supplied by each ventilation system shall be determined in accordance with Sections 403.3.1.1.2.1 through 403.3.1.1.2.3.4 as a function of system type and zone outdoor airflow rates.

403.3.1.1.2.1 Single zone systems. Where one air handler supplies a mixture of outdoor air and recirculated return air to only one zone, the system outdoor air intake flow rate (V_{ot}) shall be determined in accordance with Equation 4-3.

$$V_{ot} = V_{oz} \tag{Equation 4-3}$$

403.3.1.1.2.2 100-percent outdoor air systems. Where one air handler supplies only outdoor air to one or more zones, the system outdoor air intake flow rate (V_{ot}) shall be determined using Equation 4-4.

$$V_{ot} = \sum_{all\ zones} V_{oz} \quad \text{(Equation 4-4)}$$

[W] **403.3.1.1.2.3 Multiple zone recirculating systems.** ~~((Where))~~ For ventilation systems wherein one or more air handlers ((supplies)) supply a mixture of outdoor air and recirculated ((return)) air to more than one ventilation zone, the system outdoor air intake flow rate (V_{ot}) shall be determined in accordance with Sections 403.3.1.1.2.3.1 through 403.3.1.1.2.3.4.

403.3.1.1.2.3.1 ((Primary outdoor air fraction)) Uncorrected outdoor air intake. ~~((The primary outdoor air fraction (Z_p)) shall be determined for each zone in accordance with Equation 4-5.~~

$$Z_p = \frac{V_{oz}}{V_{pz}} \quad \text{(Equation 4-5)}$$

where:

V_{pz} = **Primary airflow:** The airflow rate supplied to the zone from the airhandling unit at which the outdoor air intake is located. It includes outdoor intake air and recirculated air from that air-handling unit but does not include air transferred or air recirculated to the zone by other means. For design purposes, V_{pz} shall be the zone design primary airflow rate, except for zones with variable air volume supply and V_{pz} shall be the lowest expected primary airflow rate to the zone when it is fully occupied.)

The uncorrected outdoor air intake flow (V_{ou}) shall be determined in accordance with Equation 4-5.

$$V_{ou} = D \sum_{all\ zones} (R_p \times P_z) + \sum_{all\ zones} (R_a \times A_z) \quad \text{(Equation 4-5)}$$

403.3.1.1.2.3.1.1 Occupant diversity. The occupant diversity ratio (D) shall be determined in accordance with Equation 4-6 to account for variations in population within the ventilation zones served by the system.

$$D = \frac{P_s}{\sum_{all\ zones} P_z} \quad \text{(Equation 4-6)}$$

where: P_s = System population: The total population in the area served by the system.

Exception: Alternative methods to account for occupant diversity shall be permitted, provided the resulting V_{ou} value is no less than that determined using Equation 4-5.

403.3.1.1.2.3.1.2 Design system population. Design system population (P_s) shall equal the largest (peak) number of people expected to occupy all ventilation zones served by the ventilation system during use.

Note: Design system population is always equal to or less than the sum of design zone population for all zones in the area served by the system because all zones may or may not be simultaneously occupied at design population.

[W] **403.3.1.1.2.3.2 System ventilation efficiency.** The system ventilation efficiency (E_v) shall be determined ~~((using Table 403.3.1.1.2.3.2))~~ in accordance with Section 403.3.1.1.2.3.3 or Appendix A of ASHRAE 62.1 for the Alternative Procedure.

Note: These procedures also establish zone minimum primary air-flow rates for VAV systems.

TABLE 403.3.1.1.2.3.2
SYSTEM VENTILATION EFFICIENCY^{a, b}

Max (Z_p)	E_v
≤ 0.15	1
≤ 0.25	0.9
≤ 0.35	0.8
≤ 0.45	0.7
≤ 0.55	0.6
≤ 0.65	0.5
≤ 0.75	0.4
> 0.75	0.3

a. Max (Z_p) is the largest value of Z_p calculated using Equation 4-5 among all the zones served by the system.

b. Interpolating between table values shall be permitted.

[W] **403.3.1.1.2.3.3 ((Uncorrected outdoor air intake)) Simplified procedure.** ~~((The uncorrected outdoor air intake flow rate (V_{ou})) shall be determined in accordance with Equation 4-6.~~

VENTILATION

$$V_{ou} = D \frac{\sum_{all\ zones} R_p P_z}{\sum_{all\ zones} R_a A_z} \quad \text{(Equation 4-6)}$$

where:

D = Occupant diversity: the ratio of the system population to the sum of the zone populations, determined in accordance with Equation 4-7.

$$D = \frac{P_s}{\sum_{all\ zones} P_z} \quad \text{(Equation 4-7)}$$

where:

P_s = System population: The total number of occupants in the area served by the system. For design purposes, P_s shall be the maximum number of occupants expected to be concurrently in all zones served by the system.)

403.3.1.1.2.3.3.1 System ventilation efficiency. System ventilation efficiency (E_v) shall be determined in accordance with Equation 4-6a or 4-6b.

$$E_v = 0.88 \times D + 0.22 \text{ for } D < 0.60 \quad \text{(Equation 4-6a)}$$

$$E_v = 0.75 \text{ for } D \geq 0.60 \quad \text{(Equation 4-6b)}$$

403.3.1.1.2.3.3.2 Zone minimum primary airflow. For each zone, the minimum primary airflow (V_{pz-min}) shall be determined in accordance with Equation 4-7.

$$V_{pz-min} = V_{oz} \times 1.5 \quad \text{(Equation 4-7)}$$

[W] **403.3.1.1.2.3.4 Outdoor air intake flow rate.** The design outdoor air intake flow rate (V_{oi}) shall be determined in accordance with Equation 4-8.

$$V_{oi} = \frac{V_{ou}}{E_v} \quad \text{(Equation 4-8)}$$

403.3.1.2 Exhaust ventilation. Exhaust airflow rate shall be provided in accordance with the requirements of Table 403.3.1.1. Outdoor air introduced into a space by an exhaust system shall be considered as contributing to the outdoor airflow required by Table 403.3.1.1.

[S] **403.3.1.3 System operation.** The minimum flow rate of outdoor air that the ventilation system must be capable of supplying during its operation shall be permitted to be based on the rate per person indicated in Table 403.3.1.1 and the actual number of occupants present. Where demand-controlled ventilation is employed to adjust the outdoor airflow rate based on the actual number of occupants present, the minimum quantity of outdoor air shall not fall below that determined from the area outdoor airflow rate column of Table 403.3.1.1 during periods when the building is expected to be occupied. For zones in the occupied standby mode, breathing zone outdoor airflow shall be permitted to be reduced to zero for the occupancy categories indicated "OS" in Table 6-1 of ASHRAE 62.1, provided that airflow is restored to V_{bz} whenever occupancy is detected.

[S] **403.3.1.4 Variable air volume system control.** Variable air volume air distribution systems, other than those designed to supply only 100-percent outdoor air, shall be provided with controls to regulate the flow of outdoor air. Such control system shall be designed to maintain the flow rate of outdoor air at a rate of not less than that required by Section 403.3 over the entire range of supply air operating rates. Calculations and a description of controls operation shall be submitted with the permit drawings.

[W] **403.3.2 Group R-2, R-3 and R-4 occupancies, three stories and less.** ~~((The design of local exhaust systems and ventilation systems for outdoor air in Group R-2, R-3 and R-4 occupancies three stories and less in height above grade plane shall comply with Sections 403.3.2.1 through 403.3.2.5.))~~ Sections 403.3.2 through 403.3.2.5 are not adopted; see Section 403.4.

~~((403.3.2.1 Outdoor air for dwelling units. An outdoor air ventilation system consisting of a mechanical exhaust system, supply system or combination thereof shall be installed for each dwelling unit. Local exhaust or supply systems, including outdoor air ducts connected to the return side of an air handler, are permitted to serve as such a system. The outdoor air ventilation system shall be designed to provide the required rate of outdoor air continuously during the period that the building is occupied. The minimum continuous outdoor airflow rate shall be determined in accordance with Equation 4-9.~~

$$Q_{OA} = 0.01 A_{floor} + 7.5(N_{br} + 1) \quad \text{(Equation 4-9)}$$

where:

- Q_{OA} = outdoor airflow rate, cfm
- A_{floor} = floor area, ft²
- N_{br} = number of bedrooms; not to be less than one

Exceptions:

1. The outdoor air ventilation system is not required to operate continuously where the system has controls that enable operation for not less than 1 hour of each 4-hour period. The average outdoor airflow rate over the 4-hour period shall be not less than that prescribed by Equation 4-9.
2. The minimum mechanical ventilation rate determined in accordance with Equation 4-9 shall be reduced by 30 percent provided that both of the following conditions apply:
 - 2.1. A ducted system supplies ventilation air directly to each bedroom and to one or more of the following rooms:
 - 2.1.1. Living room.
 - 2.1.2. Dining room.
 - 2.1.3. Kitchen.
 - 2.2. The whole-house ventilation system is a *balanced ventilation system*.

~~403.3.2.2 Outdoor air for other spaces.~~ Corridors and other common areas within the conditioned space shall be provided with outdoor air at a rate of not less than 0.06 cfm per square foot [0.0003 m³/(s • m²)] of floor area.

~~403.3.2.3 Local exhaust.~~ Local exhaust systems shall be provided in kitchens, bathrooms and toilet rooms and shall have the capacity to exhaust the minimum airflow rate determined in accordance with Table 403.3.2.3.))

**((TABLE 403.3.2.3
MINIMUM REQUIRED LOCAL EXHAUST RATES FOR GROUP R-2, R-3 AND R-4 OCCUPANCIES**

AREA TO BE EXHAUSTED	EXHAUST RATE CAPACITY
Kitchens	100 cfm intermittent or 25 cfm continuous
Bathrooms and toilet rooms	50 cfm intermittent or 20 cfm continuous

For SI: 1 cubic foot per minute = 0.0004719 m³/s.))

~~((403.3.2.4 System controls.~~ Where provided within a *dwelling unit*, controls for outdoor air ventilation systems shall include text or a symbol indicating the system's function.

~~403.3.2.5 Ventilating equipment.~~ Fans providing exhaust or outdoor air shall be *listed and labeled* to provide the minimum required air flow in accordance with ANSI/AMCA 210 ANSI/ASHRAE 51.))

[W] 403.4 Group R whole house mechanical ventilation system. Each dwelling unit or sleeping unit shall be equipped with a whole house mechanical ventilation system that complies with Sections 403.4.1 through 403.4.6.

Each dwelling unit or sleeping unit shall be equipped with local exhaust complying with Section 403.4.7. All occupied spaces, including public corridors, other than the Group R dwelling units and/or sleeping units, that support these Group R occupancies shall meet the ventilation requirement of natural ventilation requirements of Section 402 or the mechanical ventilation requirements of Sections 403.1 through 403.3.

Exception: Alternate *balanced whole house ventilation systems* and local exhaust systems subject to the Washington State Energy Code, Residential Building Provisions serving Group R dwelling units designed and commissioned in accordance with ASHRAE Standard 62.2 are permitted.

[W] 403.4.1 System design. The whole house ventilation system shall consist of one or more supply fans, one or more exhaust fans, or an ERV/HRV with integral fans; and the associated ducts and controls. Local exhaust fans shall be permitted to serve as part of the whole house ventilation system when provided with the proper controls in accordance with Section 403.4.5. The systems shall be designed and installed to supply and exhaust the minimum outdoor airflow rates in accordance with Section 403.4.2 as corrected by the balanced and/or *distributed whole house ventilation system* coefficients in accordance with Section 403.4.3 where applicable.

[W] 403.4.2 Whole house mechanical ventilation rates. The sleeping unit whole house mechanical ventilation minimum outdoor airflow rate shall be determined in accordance with the breathing zone ventilation rates minimum outdoor airflow rate shall be determined in accordance with the breathing zone ventilation rates requirements of Section 403.3.1.1.1.2 using Equation 4-2. The dwelling unit whole house mechanical ventilation minimum outdoor airflow rate shall be determined in accordance with Equation 4-10 or Table 403.4.2.

VENTILATION

**[W] TABLE 403.4.2
WHOLE HOUSE MECHANICAL VENTILATION AIRFLOW RATE
(CONTINUOUSLY OPERATING SYSTEMS)**

FLOOR AREA (ft ²)	BEDROOMS ^a				
	1	2	3	4	5
< 500	30	30	35	45	50
500 – 1000	30	35	40	50	55
1001 – 1500	30	40	45	55	60
1501 – 2000	35	45	50	60	65
2001 – 2500	40	50	55	65	70
2501 – 3000	45	55	60	70	75
3001 – 3500	50	60	65	75	80
3501 – 4000	55	65	70	80	85
4001 – 4500	60	70	75	85	90
4501 – 5000	65	75	80	90	95

a. Minimum airflow (Q_v) is set at not less than 30 cfm for each dwelling unit.

$$Q_v = 0.01 \times A_{\text{floor}} + 7.5 \times (N_{\text{br}} + 1)$$

(Equation 4-10)

where:

Q_v ≡ Ventilation airflow rate, cubic feet per minute (cfm) but not less than 30 cfm for each dwelling unit.

A_{floor} ≡ Conditioned floor area, square feet (ft²)

N_{br} ≡ Number of bedrooms, not less than one.

[W] 403.4.3 Ventilation quality adjustment. The minimum whole house ventilation rate from Section 403.4.2 shall be adjusted by the system coefficient in Table 403.4.3 based on the system type not meeting the definition of a *balanced whole house ventilation system* and/or not meeting the definition of a *distributed whole house ventilation system*.

**[W] TABLE 403.4.3
SYSTEM COEFFICIENT (C_{system})**

SYSTEM TYPE	DISTRIBUTED	NOT DISTRIBUTED
Balanced	1.0	1.25
Not Balanced	1.25	1.5

$$Q_v = Q_v \times C_{\text{system}}$$

(Equation 4-11)

where:

Q_v ≡ Quality-adjusted ventilation airflow rate in cubic feet per minute (cfm)

Q_v ≡ Ventilation airflow rate, cubic feet per minute (cfm) from Equation 4-10 or Table 403.4.2

C_{system} ≡ System coefficient from Table 403.4.2

Interpretation: Per the definition of *distributed whole house ventilation system* and per Section 403.4.4.1 and 403.4.4.2 the whole house supply fan shall provide ducted outdoor ventilation to each habitable space within the residential unit. The intent is that whole house ventilation systems are only allowed to have exhaust that is “Not Distributed.” Therefore, the “Not Distributed” system coefficients in Table 403.4.3 are only applied to the residential unit whole house ventilation airflows when intermittent local exhaust that is not part of the unit whole house ventilation system is provided in one or more of the bathrooms or kitchen of the residential unit.

[W] 403.4.4 Whole house ventilation residential occupancies. Residential dwelling and sleeping unit whole house ventilation systems shall meet the requirements of Sections 403.4.4.1 or 403.4.4.2 depending on the occupancy of the residential unit.

[W] 403.4.4.1 Whole house ventilation in Group R-2 occupancies. Residential dwelling and sleeping units in Group R-2 occupancies system shall include supply and exhaust fans and be a *balanced whole house ventilation system* in accordance with Section 403.4.6.3. The system shall include a heat or energy recovery ventilator with a sensible heat recovery effectiveness as prescribed in Section C403.3.6 or when selected as an option of R406 of the *Seattle Energy Code*. The whole house ventilation system shall operate continuously at the minimum ventilation rate determined in accordance with Section 403.4. The whole house supply fan shall provide ducted outdoor ventilation air to each habitable space within the residential unit.

Exceptions:

1. Interior adjoining spaces that are ventilated from another habitable space are not required to have outdoor air ducted directly to the adjoining space. These systems are considered *not distributed whole house ventilation systems* and shall use the “not distributed” quality adjustment system coefficient in accordance with Section 403.4.3.
2. Interior adjacent rooms that are ventilated from another habitable space are not required to have outdoor air ducted directly to the interior adjacent room. These systems are considered *not distributed whole house ventilation systems* and shall use the “not distributed” quality adjustment system coefficient in accordance with Section 403.4.3. The interior adjacent room shall be provided with a transfer fan with a minimum airflow rate of 30 cfm or with relief air inlet with a minimum airflow of 20 cfm that is connected to the exhaust/relief air inlet of an ERV/HRV whole house ventilation system. Transfer fans that ventilate interior adjacent rooms shall meet the sone rating in Section 403.4.6 and shall have whole house ventilation controls in accordance with Section 403.4.5.

[W] 403.4.4.2 Whole house ventilation for other than Group R-2 occupancies. Residential dwelling and sleeping units in other than Group R-2 occupancies, including I-1 condition 2 occupancies, shall have a whole house mechanical ventilation system with supply and exhaust fans in accordance with Section 403.4.6.1, 403.4.6.2, 403.4.6.3, or 403.4.6.4. The whole house ventilation system shall operate continuously at the minimum ventilation rate determined in accordance with Section 403.4.2 unless configured with intermittent off controls in accordance with Section 403.4.6.5. The whole house supply fan shall provide ducted outdoor ventilation air to each habitable space within the residential unit.

Exceptions:

1. Interior adjoining spaces that are ventilated from another habitable space are not required to have outdoor air ducted directly to the adjoining space. These systems are considered *not distributed whole house ventilation systems* and shall use the “not distributed” quality adjustment system coefficient in accordance with Section 403.4.3.
2. Interior adjacent rooms that are ventilated from another habitable space are not required to have outdoor air ducted directly to the interior adjacent room. These systems are considered *not distributed whole house ventilation systems* and shall use the “not distributed” quality adjustment system coefficient in accordance with Section 403.4.3. The interior adjacent room shall be provided with a transfer fan with a minimum airflow rate of 30 cfm or with relief air inlet with a minimum airflow of 20 cfm that is connected to the exhaust/relief air inlet of an ERV/HRV whole house ventilation system. Transfer fans that ventilate interior adjacent rooms shall meet the sone rating in Section 403.4.6 and shall have whole house ventilation controls in accordance with Section 403.4.5.

[W][S] 403.4.5 Whole house ventilation system controls.

1. The whole house ventilation system shall be controlled and the controls shall be readily accessible by the occupant with one or more of the following:
 - 1.1. Manual switches;
 - 1.2. Timers;
 - 1.3. Other means that provide for automatic operation of the ventilation system.
2. Whole house mechanical ventilation system shall be provided with controls that enable manual override off of the system by the occupant during periods of poor outdoor air quality. Controls shall include permanent text or a symbol indicating their function. Recommended control permanent labeling to include text similar to the following “Leave on unless outdoor air quality is very poor.” Manual controls shall be provided with ready access for the occupant.

Exception: Central whole house mechanical systems with supply air and/or exhaust that serve more than one dwelling or sleep units are not required to have manual override off controls accessible to the occupant.
3. Whole house ventilation systems shall be configured to operate continuously except where intermittent off controls are provided in accordance with Section 403.4.6.5 and allowed by Section 403.4.4.2.

[W] 403.4.6 Whole house ventilation system component requirements. Whole house ventilation supply and exhaust fans specified in this section shall have a minimum efficacy as prescribed in the *Washington State Energy Code*. The fans shall be rated for sound at a maximum of 1.0 sone at design airflow and static pressure conditions. Design and installation of the system or equipment shall be carried out in accordance with manufacturer’s installation instructions.

Exceptions:

1. Central supply or exhaust fans serving multiple residential units do not need to comply with the maximum fan sone requirements.

VENTILATION

2. Interior joining spaces provided with a 30 cfm transfer fan or a 25-square-foot permanent opening do not require supply ventilation air directly to the space. Transfer fans shall meet the same rating above and have whole house ventilation controls in accordance with Section 403.4.5.

[W] 403.4.6.1 Exhaust fans. Exhaust fans required shall be ducted directly to the outside in accordance with Section 501.3. Exhaust air outlets shall be designed to limit the pressure difference to the outside to limiting the outlet free area maximum velocity to 500 feet per minute and equipped with backdraft dampers or motorized dampers in accordance with *Washington State Energy Code*. Exhaust fans shall be tested and rated in accordance with HVI 915, HVI 916, and HVI 920. Exhaust fans required in this section may be used to provide local ventilation. Exhaust fans serving spaces other than kitchens that are designed for intermittent exhaust airflow rates in Table 403.4.7 shall be provided with occupancy sensors or humidity sensors, timer controls, or pollutant sensor controls to automatically override the fan to the high speed airflow rate. The exhaust fans shall be tested and the testing results shall be submitted and posted in accordance with Section 403.4.6.7.

Exceptions:

1. Central exhaust fans serving multiple residential units do not need to comply with the HVI testing requirements.
2. Inlet free area maximum velocity may exceed 500 feet per minute when a factory-built combined exhaust/intake termination fitting is used.

403.4.6.2 Supply fans. Supply fans used in meeting the requirements of this section shall supply outdoor air from intake openings in accordance with Sections 401.4 and 401.5. Intake air openings shall be designed to limit the pressure difference to the outside to limiting the inlet free area maximum velocity to 500 feet per minute and when designed for intermittent off operation shall be equipped with motorized dampers in accordance with the *Washington State Energy Code*. Supply fans shall be tested and rated in accordance with HVI 915, HVI 916, and HVI 920. Where outdoor air is provided to each habitable dwelling unit or sleeping unit by supply fan systems the outdoor air shall be filtered. The filter shall be provided with access for regular maintenance and replacement. The filter shall have a Minimum Efficiency Rating Value (MERV) of at least 8.

Exception: Central supply fans serving multiple residential units do not need to comply with the HVI testing requirements.

403.4.6.3 Balanced whole house ventilation system. A *balanced whole house ventilation* system shall include both supply and exhaust fans. The supply and exhaust fans shall have airflow that is within 10 percent of each other. The tested and balanced total mechanical exhaust airflow rate is within 10 percent or 5 cfm, whichever is greater, of the total mechanical supply airflow rate. The flow rate test results shall be submitted and posted in accordance with Section 403.4.6.6. The exhaust fan shall meet the requirements of Section 403.4.6.1. The supply fan shall meet the requirements of Section 403.4.6.2. For R-2 dwelling and sleeping units, the system is required to have *balanced whole house ventilation* but is not required to have *distributed whole house ventilation* where the not distributed system coefficient from Table 403.4.2 is utilized to correct the whole house mechanical ventilation rate. The system shall be designed and balanced to meet the pressure equalization requirements of Section 501.4. Local exhaust systems that are not a component of the whole-house mechanical ventilation system are exempt from the balanced airflow calculation.

403.4.6.4 Furnace integrated supply. Systems using space condition heating and/or cooling air handler fans for outdoor air supply air distribution are not permitted.

Exception: Air handler fans shall be permitted that have multi-speed or variable speed supply airflow control capability with a low speed operation not greater than 25 percent of the rated supply air flow capacity during ventilation only operation. Outdoor air intake openings must meet the provisions of Sections 401.4 and 401.5 and must include a motorized damper that is activated by the whole house ventilation system controller. Intake air openings shall be designed to limit the pressure difference to the outside to limiting the inlet free area maximum velocity to 500 feet per minute. The motorized damper must be controlled to maintain the outdoor airflow intake airflow within 10 percent of the whole house mechanical exhaust airflow rate. The supply air handler shall provide supply air to each habitable space in the residential unit. The whole house ventilation system shall include exhaust fans in accordance with Section 403.4.6.1 to meet the pressure equalization requirements of Section 501.4. The flow rate for the outdoor air intake must be tested and verified at the minimum ventilation fan speed and the maximum heating or cooling fan speed. The results of the test shall be submitted and posted in accordance with Section 403.4.6.6.

403.4.6.5 Intermittent off operation. Whole house mechanical ventilation systems shall be provided with advanced controls that are configured to operate the system with intermittent off operation and shall operate for at least two hours in each four-hour segment. The whole house ventilation airflow rate determined in accordance with Section 403.4.2 as corrected by Section 403.4.3 shall be multiplied by the factor determined in accordance with Table 403.4.6.5.

**[W] TABLE 403.4.6.5
INTERMITTENT WHOLE HOUSE MECHANICAL VENTILATION RATE FACTORS^{a,b}**

RUN-TIME PERCENTAGE IN EACH 4-HOUR SEGMENT	50%	66%	75%	100%
Factor ^d	2	1.5	1.3	1.0

- a. For ventilation system run-time values between those given, the factors are permitted to be determined by interpolation.
b. Extrapolation beyond the table is prohibited.

403.4.6.6 Testing. Whole house mechanical ventilation systems shall be tested, balanced and verified to provide a flow rate not less than the minimum required by Sections 403.4.2 and 403.4.3. Testing shall be performed according to the ventilation equipment manufacturer’s instructions, or by using a flow hood, flow grid, or other airflow measuring device at the mechanical ventilation fan’s inlet terminals, outlet terminals or grilles or in the connected ventilation ducts. Where required by the building official, testing shall be conducted by an approved third party. A written report of the results of the test shall be signed by the party conducting the test and provided to the building official and shall be posted in the residential unit in accordance with Section 403.4.6.7.

403.4.6.7 Certificate. A permanent certificate shall be completed by the mechanical contractor, test and balance contractor or other approved party and posted on a wall in the space where the furnace is located, a utility room, or an approved location inside the building. When located on an electrical panel, the certificate shall not cover or obstruct the visibility of the circuit directory label, service disconnect label, or other required labels. The certificate shall list the flow rate determined from the delivered airflow of the whole house mechanical ventilation system as installed and the type of mechanical whole house ventilation system used to comply with Section 403.4.3.

[W] 403.4.7 Local exhaust. Bathrooms, toilet rooms and kitchens shall include a local exhaust system. Such local exhaust systems shall have the capacity to exhaust the minimum airflow rate in accordance with Table 403.4.7 and Table 403.3.1.1, including notes. Fans required by this section shall be provided with controls that enable manual override or automatic occupancy sensor, humidity sensor, timer controls, or pollutant sensor controls. An “on/off” switch shall meet this requirement for manual controls. Manual fan controls shall be provided with ready access in the room served by the fan.

**[W] TABLE 403.4.7
MINIMUM EXHAUST RATES**

AREA TO BE EXHAUSTED	EXHAUST RATE	
	INTERMITTENT	CONTINUOUS
Open kitchens	In accordance with Section 403.4.7.3	Not permitted
Enclosed kitchens	In accordance with Section 403.4.7.3	5 ACH based on kitchen volume
Bathrooms–Toilet rooms	50 cfm	20 cfm

[W][S] 403.4.7.1 Combined local exhaust and whole house ventilation controls. If the local exhaust fan is included in a whole house ventilation system in accordance with Section 403.4.6, the exhaust fan shall be controlled to operate as specified in Section 403.4.5.

[W] 403.4.7.2 Local exhaust fans. Exhaust fans shall meet the following criteria:

1. Exhaust fans shall be tested and rated in accordance with HVI 915, HVI 916, and HVI 920 or equivalent.
2. Fan airflow rating and duct system shall be designed and installed to deliver at least the exhaust airflow required by Table 403.4.7. The airflows required refer to the delivered airflow of the system as installed and tested using a flow hood, flow grid, or other airflow measurement device. Local exhaust systems shall be tested, balanced and verified to provide a flow rate not less than the minimum required by this section.

Exceptions:

1. An exhaust airflow rating at a pressure of 0.25 in. w.g. may be used, provided the duct sizing meets the prescriptive requirements of Table 403.4.7.2.
2. Where a range hood or down draft exhaust fan is used to satisfy the local ventilation requirements for kitchens, the range hood or down draft exhaust shall not be less than 100 cfm at 0.10 in. w.g.
3. Design and installation of the system or equipment shall be carried out in accordance with manufacturers’ installation instructions.
4. Intermittent local exhaust system serving kitchens shall be rated for sound at a maximum of 3 sones at one or more airflow settings not less than 100 cfm at a static pressure not less than that determined at working speed as specified in HVI 916 Section 7.2.
5. Continuous local exhaust system serving kitchens shall be rated for sound at a maximum of 1 sone at one or more airflow settings not less than 100 cfm at a static pressure not less than that determined at working speed as specified in HVI 916 Section 7.2.

VENTILATION

Exceptions:

1. The installed airflow is not required to be field-verified where an exhaust airflow rating at a pressure of 0.25 in. w.g. may be used, provided the duct sizing meets the prescriptive requirements of Table 403.4.7.2.
2. Remote mounted fans need not meet sound requirements. To be considered for this exception, a remote mounted fan shall be mounted outside the kitchen, and there shall be at least 4 feet (1 m) of ductwork between the fan and the intake grille.

**[W] TABLE 403.4.7.2
PRESCRIPTIVE EXHAUST DUCT SIZING**

FAN TESTED CFM AT 0.25 INCHES W.G.	MINIMUM FLEX DIAMETER	MAXIMUM LENGTH IN FEET	MINIMUM SMOOTH DIAMETER	MAXIMUM LENGTH IN FEET	MAXIMUM ELBOWS^a
50	4 inches	25	4 inches	70	3
50	5 inches	90	5 inches	100	3
50	6 inches	No Limit	6 inches	No Limit	3
80	4 inches ^b	NA	4 inches	20	3
80	5 inches	15	5 inches	100	3
80	6 inches	90	6 inches	No Limit	3
100	5 inches ^b	NA	5 inches	50	3
100	6 inches	45	6 inches	No Limit	3
125	6 inches	15	6 inches	No Limit	3
125	7 inches	70	7 inches	No Limit	3

- a. For each additional elbow, subtract 10 feet from length.
b. Flex ducts of this diameter are not permitted with fans of this size.

[W] 403.4.7.3 Local intermittent kitchen exhaust system. Kitchen range hoods for domestic cooking appliances shall meet or exceed either the minimum airflow or the minimum capture efficiency in accordance with Table 403.4.7.3. Capture efficiency ratings shall be determined in accordance with ASTM E3087.

Exception: Other intermittent kitchen exhaust fans, including downdraft, shall meet or exceed 300 cfm airflow.

**Table 403.4.7.3
Kitchen Range Hood Airflow Rates (CFM) and ASTM E3087 Capture Efficiency (CE) Ratings
According to Kitchen Range Fuel Type**

Hood Over Electric Range	Hood Over Combustion Range
65 percent CE or 160 cfm	80 percent CE or 250 cfm

403.4.7.3.1 Field verification and diagnostic testing for local intermittent kitchen exhaust system. The local exhaust system for kitchens shall be installed to comply with local mechanical exhaust requirements specified in Section 403.4.7.3 and shall be field verified in accordance with the procedures below to confirm the model is rated by HVI or AHAM to comply with the following requirements:

1. Local intermittent exhaust system for kitchens shall be tested and verified to provide a minimum airflow rate or capture efficiency required by Section 403.4.7.3. Testing shall include verification of the maximum sound rating as specified in Section 403.4.7.2. Testing for the intermittent kitchen exhaust systems shall occur with the whole house ventilation system operating and with all dwelling unit or sleeping unit entry doors closed. Testing for exhaust systems that require mechanical makeup air in accordance with Section 505.4 shall include verifying that the mechanical makeup air opening is open. Testing for exhaust systems that require mechanical makeup air in accordance with Section 505.4 shall include verifying that the mechanical makeup air system is controlled to automatically start. Testing for exhaust systems that do not require mechanical makeup air in accordance with Section 505.4 and that are exempt from pressurize equalization per Section 501.4 shall be tested with operable openings manually opened unless design exhaust airflow can be achieved with all operable openings closed. Where required by the building official, testing shall be conducted by an approved third party. A written report of the results of the test shall be signed by the party conducting the test and provided to the building official.

Exception: The installed airflow is not required to be field-verified where an exhaust airflow rating at a pressure of 0.25 inches w.g. is used, provided the duct sizing meets the prescriptive requirements of Table 403.4.7.2.

2. The verification shall utilize certified rating data from HVI Publication 911, AHAM-Certified Range Hood Directory or another directory of certified product performance ratings approved by the code official for determining compliance. The verification procedure shall consist of visual inspection of the local intermittent kitchen exhaust system to verify and record the following information:
 - 2.1. The manufacturer name and model number.
 - 2.2. The model is listed in the HVI, AHAM, or equivalent directory.
 - 2.3. The rated airflow value listed in the HVI, AHAM or equivalent directory.
 - 2.4. The sound rating value listed in the HVI, AHAM or equivalent directory.
 - 2.5. If the value for the rated airflow given in the directory is greater than or equal to the airflow requirements specified in Section 403.4.7.3 and if the value for the sone rating given in the directory is less than or equal to the sone rating requirements specified in Section 403.4.7.2, then the local intermittent kitchen exhaust system complies, otherwise the local intermittent kitchen exhaust system does not comply.

[S] SECTION 404

ENCLOSED PARKING GARAGES, LOADING DOCKS AND MOTOR VEHICLE REPAIR GARAGES

[S] **404.1 Enclosed parking garages.** Mechanical ventilation systems for enclosed parking garages shall operate continuously or shall be automatically operated by means of carbon monoxide detectors applied in conjunction with nitrogen dioxide detectors. Such detectors shall be listed in accordance with UL 2075 and installed in accordance with their listing and the manufacturer's instructions. Loss of communication with the carbon monoxide or nitrogen dioxide detectors shall cause the exhaust fans to operate continuously at full-on design airflow. Automatic operation shall cycle the ventilation system between the following two modes of operation:

1. Full-on at an airflow rate of not less than 0.75 cfm per square foot [$0.0038 \text{ m}^3 / (\text{s} \cdot \text{m}^2)$] of the floor area served.
2. Standby at an airflow rate of not less than 0.05 cfm per square foot [$0.00025 \text{ m}^3 / (\text{s} \cdot \text{m}^2)$] of the floor area served.

404.2 Occupied spaces accessory to public garages. Connecting offices, waiting rooms, ticket booths, and similar uses that are accessory to a public garage shall be maintained at a positive pressure and shall be provided with ventilation in accordance with Section 403.3.1.

404.3 Enclosed loading dock. Mechanical ventilation systems for enclosed parking garages shall operate continuously or shall be automatically operated by means of carbon monoxide detectors applied in conjunction with nitrogen dioxide detectors. Such detectors shall be listed in accordance with UL 2075 and installed in accordance with their listing and the manufacturers' instructions. Loss of communication with the carbon monoxide or nitrogen dioxide detectors shall cause the exhaust fans to operate continuously at full-on design airflow. Automatic operation shall cycle the ventilation system between the following two modes of operation:

1. Full-on at an airflow rate of not less than 1.5 cfm per square foot [$0.0076 \text{ m}^3 / (\text{s} \cdot \text{m}^2)$] of the floor area served.
2. Standby at an airflow rate of not less than 0.30 cfm per square foot [$0.00017 \text{ m}^3 / (\text{s} \cdot \text{m}^2)$] of the floor area served.

404.4 Enclosed automated parking system areas. Mechanical ventilation systems for enclosed automated parking system areas where the engines of the motor vehicles are not operating shall operate continuously to provide a minimum airflow rate of 50 cfm per parking stall. This does not apply to the vehicle drop off area where vehicles are operating as these area shall comply with Section 404.1.

404.5 Motor vehicle repair garages. In buildings used for the repair of motor vehicles, each repair stall or stand shall be equipped with an exhaust capture system that connects directly to the repair engine exhaust source and prevents the escape of fumes. The exhaust system shall exhaust to the outdoor atmosphere. See Section 502.15 for additional requirements. Ventilation shall be provided for the motor vehicle repair garage in accordance with Section 404.1.

SECTION 405 SYSTEMS CONTROL

[S] **405.1 General.** Mechanical ventilation systems shall be provided with manual or automatic controls that will operate such systems whenever the spaces are occupied. Air-conditioning systems that supply required *ventilation air* shall be provided with controls designed to automatically maintain the required outdoor air supply rate during occupancy. Additional mechanical system control requirements are contained in the International Energy Conservation Code.

VENTILATION

**SECTION 406
VENTILATION OF UNINHABITED SPACES**

[S] 406.1 General. (~~Uninhabited spaces, such as crawl~~) Crawl spaces and attics ((;)) shall be provided with *natural ventilation* openings as required by the *International Building Code* or shall be provided with a mechanical exhaust and supply air system. The mechanical exhaust rate shall be not less than 0.02 cfm per square foot (0.00001 m³/s • m²) of horizontal area and shall be automatically controlled to operate when the relative humidity in the space served exceeds 60 percent.

**SECTION 407
AMBULATORY CARE FACILITIES AND GROUP I-2 OCCUPANCIES**

[W] 407.1 General. Mechanical ventilation for healthcare facilities licensed by Washington State shall be designed and installed in accordance with this code and the following provisions of the Washington Administrative Code (WAC):

1. Mechanical ventilation in ambulatory care facilities shall comply with chapter 246-330 WAC.
2. Mechanical ventilation for acute care hospitals shall comply with chapter 246-320 WAC.
3. Mechanical ventilation for nursing homes shall comply with chapter 388-97 WAC.

Mechanical ventilation for unlicensed ambulatory care facilities (~~and Group I-2 occupancies~~) shall be designed and installed in accordance with this code, ASHRAE 170 and NFPA 99.

CHAPTER 5

EXHAUST SYSTEMS

User note:

About this chapter: Chapter 5 addresses exhaust systems for, among others, kitchens, laboratories, processes, garages, hazardous systems, clothes dryers and smoke control systems. Many provisions are linked to the International Fire Code®. Exhaust systems mitigate health and fire hazards by removing and diluting contaminants in buildings. Exhaust system discharge location is also addressed as an important concern.

SECTION 501 GENERAL

501.1 Scope. This chapter shall govern the design, construction and installation of mechanical exhaust systems, including exhaust systems serving clothes dryers and cooking *appliances*; hazardous exhaust systems; dust, stock and refuse conveyor systems; subslab soil exhaust systems; smoke control systems; energy recovery ventilation systems and other systems specified in Section 502.

501.2 Independent system required. Single or combined mechanical exhaust systems for environmental air shall be independent of all other exhaust systems. Dryer, domestic kitchen and hazardous exhaust shall be independent of all other systems. Type I exhaust systems shall be independent of all other exhaust systems except as provided in Section 506.3.5. Single or combined Type II exhaust systems for food-processing operations shall be independent of all other exhaust systems. Commercial kitchen exhaust systems shall be constructed in accordance with Sections 506 through 509.

[S] 501.3 Exhaust discharge. The air removed by every mechanical exhaust system shall be discharged outdoors at a point where it will not cause a public nuisance and not less than the distances specified in Section 501.3.1. The air shall be discharged to a location from which it cannot again be readily drawn in by a ventilating system. Air shall not be exhausted into an attic or crawl space, or be directed onto walkways.

Exceptions:

1. Whole-house ventilation-type attic fans shall be permitted to discharge into the attic space of *dwelling units* having private attics.
2. Commercial cooking recirculating systems are not required to discharge outdoors if the kitchen area has an exhaust system that is vented to the outside. Ventilation shall be provided in accordance with Chapter 4.
3. Where installed in accordance with the manufacturer's instructions and where mechanical or *natural ventilation* is otherwise provided in accordance with Chapter 4, *listed* and *labeled* domestic ductless range hoods shall not be required to discharge to the outdoors.

[W][S] 501.3.1 Location of exhaust outlets. The termination point of exhaust outlets and ducts discharging to the outdoors shall be located with the following minimum distances:

1. For ducts conveying explosive or flammable vapors, fumes or dusts: 30 feet (9144 mm) from property lines; 10 feet (3048 mm) from operable openings into ~~((buildings))~~ the building; 6 feet (1829 mm) from exterior walls and roofs; 30 feet (9144 mm) from combustible walls and operable openings into ~~((buildings that))~~ the building which are in the direction of the exhaust discharge; 10 feet (3048 mm) above adjoining grade.

Interpretation: Item 1 includes carpentry shop exhaust, industrial chemical lab, paint shop and sandblasting exhaust systems. For *clearances* and encroachments in the public right-of-way, see Section 304.13.

2. For other product-conveying outlets: 10 feet (3048 mm) from the property lines; 3 feet (914 mm) from exterior walls and roofs; 10 feet (3048 mm) from operable openings into buildings; 10 feet (3048 mm) above adjoining grade.

Interpretation: Item 2 includes central vacuum systems, dry cleaner, photo lab, school chemical lab, nail salon, dryer exhaust over 250° *source capture system* exhaust and *combustion engine* exhaust and refrigerant pipe shaft ventilation exhaust outlets covered under Section 1109.3.2 carrying Group A2L and Group B2L refrigerants.

- [W]** 3. For all *environmental air* exhaust other than enclosed parking garage and transformer vault exhaust: 3 feet (914 mm) from property lines, ~~((;))~~ 3 feet (914 mm) from operable openings into buildings for all *occupancies* other than Group U; and 10 feet (3048 mm) from mechanical air intakes. Such exhaust shall not be considered hazardous or

EXHAUST SYSTEMS

noxious. Separation is not required between intake air openings and (~~(living space exhaust)~~) environmental air other than kitchen exhaust openings of (~~(an individual)~~) the same dwelling unit or sleeping unit where an approved factory-built intake/exhaust combination termination fitting is used to separate the air streams in accordance with the manufacturer's instructions.

Interpretation: For the purposes of this section, "lot line" includes any property line separating one lot from another lot, but does not include any property line separating a lot from a public street or alley right-of-way.

Exceptions:

1. The separation between an air intake and exhaust outlet on a single listed package HVAC unit.
2. Exhaust from environmental air systems other than garages may be discharged into an open parking garage.
3. Except for Group I occupancies, where ventilation system design circumstances require building HVAC air to be relieved, such as during economizer operation, such air may be relieved into an open or enclosed parking garage within the same building.
4. Exhaust outlets serving structures in flood hazard areas shall be installed at or above the elevation required by Section 1612 of the *International Building Code* for utilities and attendant equipment.
5. For enclosed parking garage, loading dock, and motor vehicle repair garage exhaust system outlets: Exhaust ventilation openings and duct terminations shall be located not less than 10 feet (3048 mm) from property lines which separate one lot from another; 10 feet from operable openings into buildings and mechanical air intakes; and 3 feet (914 mm) horizontally from, 10 feet above, or 10 feet below adjoining finished walking surfaces other than alleys. Exhaust outlets extending to the roof shall extend 3 feet (914 mm) above the roof surface.

[W][S] 6. For transformer vault exhaust system outlets: Exhaust ventilation openings and duct terminations, subject to the requirements of *Seattle Electrical Code* Section 450.45, shall be located not less than 10 feet (3048 mm) from:

- 6.1. Fire escapes;
- 6.2. Required means of egress at the exterior of the building;
- 6.3. Elements of the exit discharge;
- 6.4. Exterior combustible materials;
- 6.5. Openings that are not protected in accordance with IBC Section 705.8;
- 6.6. Property lines which separate one lot from another other than a public way;
- 6.7. Operable openings and mechanical intakes; and
- 6.8. Above or below any walking surface.

Exhaust outlets shall be located on the exterior of the building.

Note: See *Seattle City Light Standard 751 Section 9 Ventilation* and *Seattle Building Code Section 430* for additional requirements.

[W] 7. For elevator machinery rooms in enclosed or open parking garages: Exhaust outlets may discharge air directly into the parking garage.

~~((5))~~ 8. For specific systems, see the following sections:

- ~~((5-1))~~ 8.1. Clothes dryer exhaust, Section 504.4.
- ~~((5-2))~~ 8.2. Kitchen hoods and other kitchen exhaust *equipment*, Sections 506.3.13, 506.4 and 506.5.
- ~~((5-3))~~ 8.3. Dust, stock and refuse conveying systems, Section 511.2.
- ~~((5-4))~~ 8.4. Subslab soil exhaust systems, Section 512.4.
- ~~((5-5))~~ 8.5. Smoke control systems, Section 513.10.3.
- ~~((5-6))~~ 8.6. Refrigerant discharge, Section 1105.7.
- ~~((5-7))~~ 8.7. *Machinery room* discharge, Section 1105.6.1.

Note: *Seattle Land Use Code* (Municipal Code Title 23) requires that the venting of odors, vapors, smoke, cinders, dust, gas and fumes shall be at least 10 feet (3048 mm) above finished sidewalk grade, and directed away as much as possible from residential uses within 50 feet (15 240 mm) of the vent in some locations.

501.3.2 Exhaust opening protection. Exhaust openings that terminate outdoors shall be protected with corrosion-resistant screens, louvers or grilles. Openings in screens, louvers and grilles shall be sized not less than 1/4 inch (6.4 mm) and not larger than 1/2 inch (12.7 mm). Openings shall be protected against local weather conditions. Louvers that protect exhaust

openings in structures located in hurricane-prone regions, as defined in the *International Building Code*, shall comply with AMCA Standard 550. Outdoor openings located in exterior walls shall meet the provisions for exterior wall opening protectives in accordance with the *International Building Code*.

[W] **501.4 Pressure equalization.** Mechanical exhaust systems shall be sized to remove the quantity of air required by this chapter to be exhausted. The system shall operate when air is required to be exhausted. Where mechanical exhaust is required in a room or space, ~~((in other than occupancies in Group R-3 and dwelling units in Group R-2,))~~ such space shall be maintained with a neutral or negative pressure. If a greater quantity of air is supplied by a mechanical ventilating supply system than is removed by a mechanical exhaust for a room, adequate means shall be provided for the natural or mechanical exhaust of the excess air supplied. If only a mechanical exhaust system is installed for a room or if a greater quantity of air is removed by a mechanical exhaust system than is supplied by a mechanical ventilating supply system for a room, adequate *makeup air* shall be provided to satisfy the deficiency.

Exception: Intermittent kitchen exhaust, intermittent domestic dryer exhaust, and intermittent local exhaust system in R-3 occupancies and dwelling units in R-2 occupancies are excluded from the pressure equalization requirement unless required by Section 504 or Section 505.

501.5 Ducts. Where exhaust duct construction is not specified in this chapter, such construction shall comply with Chapter 6.

SECTION 502 REQUIRED SYSTEMS

[S] **502.1 General.** An exhaust system shall be provided, maintained and operated as specifically required by this section and for all occupied areas where machines, vats, tanks, furnaces, forges, salamanders and other *appliances, equipment* and processes in such areas produce or throw off dust or particles sufficiently light to float in the air, or emit heat, odors, fumes, spray, gas or smoke in such quantities so as to be irritating or injurious to health or safety. These exhaust systems are considered *product-conveying systems*.

[S] **502.1.1 Exhaust inlet location.** The inlet to an exhaust system shall be located in the area of heaviest concentration of contaminants.

[F] **502.1.2 Fuel-dispensing areas.** The bottom of an air inlet or exhaust opening in fuel-dispensing areas shall be located not more than 18 inches (457 mm) above the floor.

502.1.3 Equipment, appliance and service rooms. *Equipment, appliance* and system service rooms that house sources of odors, fumes, noxious gases, smoke, steam, dust, spray or other contaminants shall be designed and constructed so as to prevent spreading of such contaminants to other occupied parts of the building.

[F] **502.1.4 Hazardous exhaust.** The mechanical exhaust of high concentrations of dust or hazardous vapors shall conform to the requirements of Section 510.

[F] **502.2 Aircraft fueling and defueling.** Compartments housing piping, pumps, air eliminators, water separators, hose reels and similar *equipment* used in aircraft fueling and defueling operations shall be adequately ventilated at floor level or within the floor itself.

[F] **502.3 Battery-charging areas for powered industrial trucks and equipment.** Ventilation shall be provided in an *approved* manner in battery-charging areas for powered industrial trucks and *equipment* to prevent a dangerous accumulation of flammable gases.

[S][F] **502.4 ~~((Stationary storage battery))~~ Energy storage systems.** ~~((Stationary storage battery))~~ Exhaust ventilation of rooms, areas and walk-in units containing electrochemical energy storage systems shall be regulated and ventilated in accordance with Section 1207.6.1 of the *International Fire Code*, this section, and the general requirements of this chapter.

502.4.1 Ventilation based on lower flammable limit (LFL). The exhaust ventilation system shall be designed to limit the maximum concentration of flammable gas to 25 percent of the lower flammable limit (LFL) of the total volume of the room, area or walk-in unit during the worst-case event of simultaneous charging of batteries at the maximum charge rate, in accordance with nationally recognized standards.

502.4.2 Ventilation based on exhaust rate. Mechanical exhaust ventilation shall be provided at a rate of not less than 1 ft³/min/ft² (5.1 L/sec/m²) of floor area of the room, area or walk-in unit. The ventilation shall be either continuous or shall be activated by a gas detection system in accordance with Seattle Fire Code Section 1207.6.1.2.4.

502.4.3 Energy storage system gas detection system. Where a gas detection system is installed that complies with *Seattle Fire Code* Section 916, the mechanical ventilation system shall remain on until the flammable gas detected is less than 25 percent of the LFL.

[F] **502.5 Ventilation of battery systems in cabinets.** Stationary storage battery systems installed in cabinets shall be provided with ventilation in accordance with Section 502.4.

EXHAUST SYSTEMS

[F] **502.6 Dry cleaning plants.** Ventilation in dry cleaning plants shall be adequate to protect employees and the public in accordance with this section and DOL 29 CFR Part 1910.1000, where applicable.

[F] **502.6.1 Type II systems.** Type II dry cleaning systems shall be provided with a mechanical ventilation system that is designed to exhaust 1 cubic foot of air per minute for each square foot of floor area (1 cfm/ft²) [0.00508 m³/ (s • m²)] in dry cleaning rooms and in drying rooms. The ventilation system shall operate automatically when the dry cleaning *equipment* is in operation and shall have manual controls at an *approved* location.

[F] **502.6.2 Type IV and V systems.** Type IV and V dry cleaning systems shall be provided with an automatically activated exhaust ventilation system to maintain an air velocity of not less than 100 feet per minute (0.51 m/s) through the loading door when the door is opened.

Exception: Dry cleaning units are not required to be provided with exhaust ventilation where an exhaust hood is installed immediately outside of and above the loading door and operates at an airflow rate as follows:

$$Q = 100 \times A_{LD} \quad \text{(Equation 5-1)}$$

where:

Q = Flow rate exhausted through the hood, cubic feet per minute.

A_{LD} = Area of the loading door, square feet.

[F] **502.6.3 Spotting and pretreating.** Scrubbing tubs, scouring, brushing or spotting operations shall be located such that solvent vapors are captured and exhausted by the ventilating system.

[S][F] **502.7 Application of flammable finishes.** Mechanical exhaust as required by this section shall be provided for operations involving the application of flammable finishes. Spray finishing operations conducted in Group A, E, I or R occupancies shall be located in a spray room protected with an approved automatic sprinkler system installed in accordance with International Building Code Section 903.3.1.1 and separated vertically and horizontally from other areas in accordance with the International Building Code. In other occupancies, spray-finishing operations shall be conducted in a spray room, spray booth or limited spraying area approved for such use.

[F] **502.7.1 During construction.** Ventilation shall be provided for operations involving the application of materials containing flammable solvents in the course of construction, *alteration* or demolition of a structure.

[S][F] **502.7.2 Limited spraying spaces.** Positive mechanical ventilation that provides not less than six complete air changes per hour shall be installed in limited spraying spaces. Such system shall meet the requirements of the *International Fire Code* for handling flammable vapors. Explosion venting is not required.

Exception: Negative mechanical ventilation, providing a minimum of six complete air changes per hour, is allowed in lieu of positive mechanical ventilation if a fan rated for Class I, Division 2 hazardous locations in accordance with the Seattle Electrical Code is installed.

[F] **502.7.3 Flammable vapor areas.** Mechanical ventilation of flammable vapor areas shall be provided in accordance with Sections 502.7.3.1 through 502.7.3.6.

[F] **502.7.3.1 Operation.** Mechanical ventilation shall be kept in operation at all times while spraying operations are being conducted and for a sufficient time thereafter to allow vapors from drying coated articles and finishing material residue to be exhausted. Spraying *equipment* shall be interlocked with the ventilation of the flammable vapor area such that spraying operations cannot be conducted unless the ventilation system is in operation.

[F] **502.7.3.2 Recirculation.** Air exhausted from spraying operations shall not be recirculated.

Exceptions:

1. Air exhausted from spraying operations shall be permitted to be recirculated as *makeup air* for unmanned spray operations provided that:
 - 1.1. The solid particulate has been removed.
 - 1.2. The vapor concentration is less than 25 percent of the lower flammable limit (LFL).
 - 1.3. *Approved equipment* is used to monitor the vapor concentration.
 - 1.4. An alarm is sounded and spray operations are automatically shut down if the vapor concentration exceeds 25 percent of the LFL.
 - 1.5. In the event of shutdown of the vapor concentration monitor, 100 percent of the air volume specified in Section 510 is automatically exhausted.
2. Air exhausted from spraying operations is allowed to be recirculated as *makeup air* to manned spraying operations where all of the conditions provided in Exception 1 are included in the installation and documents have been prepared to show that the installation does not pose a life safety hazard to personnel inside the spray booth, spraying space or spray room.

2. Workstations: A ventilation system shall be provided to capture and exhaust gases, fumes and vapors at workstations.
3. Liquid storage rooms: Exhaust ventilation for liquid storage rooms shall comply with Section 502.8.1.1 and the *International Building Code*.
4. HPM rooms: Exhaust ventilation for HPM rooms shall comply with Section 502.8.1.1 and the *International Building Code*.
5. Gas cabinets: Exhaust ventilation for gas cabinets shall comply with Section 502.8.2. The gas cabinet ventilation system is allowed to connect to a workstation ventilation system. Exhaust ventilation for gas cabinets containing highly toxic or toxic gases shall also comply with Sections 502.9.7 and 502.9.8.
6. Exhausted enclosures: Exhaust ventilation for exhausted enclosures shall comply with Section 502.8.2. Exhaust ventilation for exhausted enclosures containing highly toxic or toxic gases shall also comply with Sections 502.9.7 and 502.9.8.
7. Gas rooms: Exhaust ventilation for gas rooms shall comply with Section 502.8.2. Exhaust ventilation for gas rooms containing highly toxic or toxic gases shall also comply with Sections 502.9.7 and 502.9.8.
8. Cabinets containing pyrophoric liquids or Class 3 water-reactive liquids: Exhaust ventilation for cabinets in fabrication areas containing pyrophoric liquids shall be as required in Section 2705.2.3.4 of the *International Fire Code*.

[F] **502.10.2 Penetrations.** Exhaust ducts penetrating fire barriers constructed in accordance with Section 707 of the *International Building Code* or horizontal assemblies constructed in accordance with Section 711 of the *International Building Code* shall be contained in a shaft of equivalent fire-resistance-rated construction. Exhaust ducts shall not penetrate fire walls. Fire dampers shall not be installed in exhaust ducts.

[F] **502.10.3 Treatment systems.** Treatment systems for highly toxic and toxic gases shall comply with the *International Fire Code*.

502.11 Motion picture projectors. Motion picture projectors shall be exhausted in accordance with Section 502.11.1 or 502.11.2.

502.11.1 Projectors with an exhaust discharge. Projectors equipped with an exhaust discharge shall be directly connected to a mechanical exhaust system. The exhaust system shall operate at an exhaust rate as indicated by the manufacturer's installation instructions.

502.11.2 Projectors without exhaust connection. Projectors without an exhaust connection shall have contaminants exhausted through a mechanical exhaust system. The exhaust rate for electric arc projectors shall be not less than 200 cubic feet per minute (cfm) (0.09 m³/s) per lamp. The exhaust rate for xenon projectors shall be not less than 300 cfm (0.14 m³/s) per lamp. Xenon projector exhaust shall be at a rate such that the exterior temperature of the lamp housing does not exceed 130°F (54°C). The lamp and projection room exhaust systems, whether combined or independent, shall not be interconnected with any other exhaust or return system within the building.

[F] **502.12 Organic coating processes.** Enclosed structures involving organic coating processes in which Class I liquids are processed or handled shall be ventilated at a rate of not less than 1 cfm/ft² [0.00508 m³/(s • m²)] of solid floor area. Ventilation shall be accomplished by exhaust fans that intake at floor levels and discharge to a safe location outside the structure. Noncontaminated intake air shall be introduced in such a manner that all portions of solid floor areas are provided with continuous uniformly distributed air movement.

502.13 Public garages. Mechanical exhaust systems for public garages, as required in Chapter 4, shall operate continuously or in accordance with Section 404.

[S] **502.14 Motor vehicle operation.** In areas where motor vehicles operate, mechanical ventilation shall be provided in accordance with Section 403. Additionally, areas in which stationary motor vehicles are operated shall be provided with a *source capture system* that connects directly to the motor vehicle exhaust systems. When the source capture system extends more than 10 feet from the tailpipe connection to the outdoors, the system shall exhaust at a rate of 600 cfm for heavy-duty diesel vehicles and at a rate of 300 cfm for all other vehicles. Such system shall be engineered by a registered design professional. ~~((or shall be factory-built equipment designed and sized for the purpose.))~~

Exceptions:

1. This section shall not apply where the motor vehicles being operated or repaired are electrically powered.
2. This section shall not apply to one- and two-family dwellings.
3. This section shall not apply to motor vehicle service areas where engines are operated inside the building only for the duration necessary to move the motor vehicles in and out of the building.

[S][F] **502.15 Repair garages and other spaces.** Where Class I liquids or LP-gas are stored or used within a building having a basement or pit wherein flammable vapors could accumulate, the basement or pit shall be provided with ventilation designed to prevent the accumulation of flammable vapors therein.

EXHAUST SYSTEMS

[F] 502.16 Repair garages for vehicles fueled by lighter-than-air fuels. Repair garages used for the conversion and repair of vehicles that use compressed natural gas, liquefied natural gas, hydrogen or other lighter-than-air motor fuels shall be provided with an *approved* mechanical exhaust ventilation system. The mechanical exhaust ventilation system shall be in accordance with Section 502.16.1 or 502.16.2 as applicable.

Exceptions:

1. Repair garages where work is not performed on the fuel system and is limited to exchange of parts and maintenance not requiring open flame or welding on the compressed natural gas, liquefied natural gas, hydrogen or other lighter-than-air-fueled motor vehicle.
2. Repair garages for hydrogen-fueled vehicles where work is not performed on the hydrogen storage tank and is limited to the exchange of parts and maintenance not requiring open flame or welding on the hydrogen-fueled vehicle. During the work, the entire hydrogen fuel system shall contain a quantity of hydrogen that is less than 200 cubic feet (5.6 m³).

[F] 502.16.1 Repair garages for hydrogen-fueled vehicles. Repair garages used for the repair of hydrogen-fueled vehicles shall be provided with an approved exhaust ventilation system in accordance with this code and Chapter 6 of NFPA 2.

[F] 502.16.2 Exhaust ventilation system. Repair garages used for the repair of compressed natural gas, liquefied natural gas or other lighter-than-air motor fuel, other than hydrogen, shall be provided with an approved mechanical exhaust ventilation system. The mechanical exhaust ventilation system shall be in accordance with this code and Sections 502.16.2.1 and 502.16.2.2.

Exception: Where approved, natural ventilation shall be an alternative to mechanical exhaust ventilation.

[F] 502.16.2.1 Design. For indoor locations, air supply inlets and exhaust outlets for mechanical ventilation shall be arranged to provide uniformly distributed air movement with inlets uniformly arranged on walls near floor level and outlets located at the high point of the room in walls or the roof.

Failure of the exhaust ventilation system shall cause the fueling system to shut down.

The exhaust ventilation rate shall be not less than 1 cubic foot per minute (0.03 m³/min) per 12 cubic feet (0.34 m³) of room volume.

[F] 502.16.2.2 Operation. The mechanical exhaust ventilation system shall operate continuously.

Exceptions:

1. Mechanical exhaust ventilation systems that are interlocked with a gas detection system designed in accordance with the *International Fire Code*.
2. Mechanical exhaust ventilation systems in garages that are used only for the repair of vehicles fueled by liquid fuels or odorized gases, such as compressed natural gas, where the exhaust ventilation system is electrically interlocked with the lighting circuit.

502.17 Tire rebuilding or recapping. Each room where rubber cement is used or mixed, or where flammable or combustible solvents are applied, shall be ventilated in accordance with the applicable provisions of NFPA 91.

502.17.1 Buffing machines. Each buffing machine shall be connected to a dust-collecting system that prevents the accumulation of the dust produced by the buffing process.

502.18 Specific rooms. Specific rooms, including bathrooms, locker rooms, smoking lounges and toilet rooms, shall be exhausted in accordance with the ventilation requirements of Chapter 4.

Informative Note: RCW 70.160.030 states: “No person may smoke in a public place or in any place of employment.” A public place is defined in RCW 70.160.020 in part as: “...A public place does not include a private residence unless the private residence is used to provide licensed child care, foster care, adult care, or other similar social service care on the premises. This chapter is not intended to restrict smoking in private facilities which are occasionally open to the public except upon the occasions when the facility is open to the public.”

502.19 Indoor firing ranges. Ventilation shall be provided in an *approved* manner in areas utilized as indoor firing ranges. Ventilation shall be designed to protect employees and the public in accordance with DOL 29 CFR 1910.1025 where applicable.

502.20 Manicure and pedicure stations. Manicure and pedicure stations shall be provided with an exhaust system in accordance with Table 403.3.1.1, Note h. Manicure tables and pedicure stations not provided with factory-installed exhaust inlets shall be provided with exhaust inlets located not more than 12 inches (305 mm) horizontally and vertically from the point of chemical application.

[S] 502.20.1 Operation. The exhaust system for manicure and pedicure stations shall have ~~((controls))~~ automatic control, occupancy sensors or other approved automatic controls, that operate the system continuously when the space is occupied.

SECTION 503 MOTORS AND FANS

503.1 General. Motors and fans shall be sized to provide the required air movement. Motors in areas that contain flammable vapors or dusts shall be of a type *approved* for such environments. A manually operated remote control installed at an *approved* location shall be provided to shut off fans or blowers in flammable vapor or dust systems. Electrical *equipment* and *appliances* used in operations that generate explosive or flammable vapors, fumes or dusts shall be interlocked with the ventilation system so that the *equipment* and *appliances* cannot be operated unless the ventilation fans are in operation. Motors for fans used to convey flammable vapors or dusts shall be located outside the duct or shall be protected with *approved* shields and dustproofing. Motors and fans shall be provided with a means of access for servicing and maintenance.

503.2 Fans. Parts of fans in contact with explosive or flammable vapors, fumes or dusts shall be of nonferrous or nonsparking materials, or their casing shall be lined or constructed of such material. Where the size and hardness of materials passing through a fan are capable of producing a spark, both the fan and the casing shall be of nonsparking materials. Where fans are required to be spark resistant, their bearings shall not be within the airstream, and all parts of the fan shall be grounded. Fans in systems-handling materials that are capable of clogging the blades, and fans in buffing or woodworking exhaust systems, shall be of the radial-blade or tube-axial type.

503.3 Equipment and appliance identification plate. *Equipment* and *appliances* used to exhaust explosive or flammable vapors, fumes or dusts shall bear an identification plate stating the ventilation rate for which the system was designed.

503.4 Corrosion-resistant fans. Fans located in systems conveying corrosives shall be of materials that are resistant to the corrosive or shall be coated with corrosion-resistant materials.

SECTION 504 CLOTHES DRYER EXHAUST

504.1 Installation. Clothes dryers shall be exhausted in accordance with the manufacturer's instructions. Dryer exhaust systems shall convey the moisture and any products of *combustion* to the outside of the building.

Exception: This section shall not apply to *listed* and *labeled* condensing (ductless) clothes dryers.

504.2 Exhaust penetrations. Where a clothes dryer exhaust duct penetrates a wall or ceiling membrane, the annular space shall be sealed with noncombustible material, *approved* fire caulking or a noncombustible dryer exhaust duct wall receptacle. Ducts that exhaust clothes dryers shall not penetrate or be located within any fireblocking, draft-stopping or any wall, floor/ceiling or other assembly required by the *International Building Code* to be fire-resistance rated, unless such duct is constructed of galvanized steel or aluminum of the thickness specified in Section 603.4 and the fire-resistance rating is maintained in accordance with the *International Building Code*. Fire dampers, combination fire/smoke dampers and any similar devices that will obstruct the exhaust flow shall be prohibited in clothes dryer exhaust ducts.

[S] 504.2.1 Protection required. Protective shield plates shall be placed where nails or screws from finish or other work are likely to penetrate the clothes dryer exhaust duct. Shield plates shall be placed on the finished face of all framing members where there is less than 1-1/4 inches (32 mm) between the duct and the finished face of the framing member. Protective shield plates shall be constructed of steel, have a thickness of 0.062 inch (1.6 mm) and extend a minimum of 2 inches (51 mm) above sole plates and below top plates.

504.3 Cleanout. Each vertical riser shall be provided with a means for cleanout.

[W] 504.4 Exhaust installation. Dryer exhaust ducts for clothes dryers shall terminate on the outside of the building and shall be equipped with a backdraft damper located where the duct terminates. Dryer exhaust ducts may terminate at exterior wall louvers with openings spaced not less than 1/2" in any direction. Screens shall not be installed at the duct termination. Ducts shall not be connected or installed with sheet metal screws or other fasteners that will obstruct the exhaust flow. Clothes dryer exhaust ducts shall not be connected to a vent connector, vent or *chimney*. Clothes dryer exhaust ducts shall not extend into or through ducts or *plenums*. ~~((Clothes dryer exhaust ducts shall be sealed in accordance with Section 603.9.))~~ Domestic dryer exhaust ducts may terminate at a common exhaust location where each duct has an independent back-draft damper.

504.4.1 Termination location. Exhaust duct terminations shall be in accordance with the dryer manufacturer's installation instructions. Where the manufacturer's instructions do not specify a termination location, the exhaust duct shall terminate not less than 3 feet (914 mm) in any direction from openings into buildings, including openings in ventilated soffits.

504.4.2 Exhaust termination outlet and passageway size. The passageway of dryer exhaust duct terminals shall be undiminished in size and shall provide an open area of not less than 12.5 square inches (8065 mm²).

504.5 Dryer exhaust duct power ventilators. Domestic dryer exhaust duct power ventilators shall be *listed* and *labeled* to UL 705 for use in dryer exhaust duct systems. The dryer exhaust duct power ventilator shall be installed in accordance with the manufacturer's instructions.

504.6 Booster fans prohibited. Domestic booster fans shall not be installed in dryer exhaust systems.

EXHAUST SYSTEMS

504.7 Makeup air. Installations exhausting more than 200 cfm (0.09 m³/s) shall be provided with *makeup air*. Where a closet is designed for the installation of a clothes dryer, an opening having an area of not less than 100 square inches (0.0645 m²) shall be provided in the closet enclosure or *makeup air* shall be provided by other *approved* means.

~~[S] ((504.8) **Protection required.** Protective shield plates shall be placed where nails or screws from finish or other work are likely to penetrate the clothes dryer exhaust duct. Shield plates shall be placed on the finished face of all framing members where there is less than 1 1/4 inches (32 mm) between the duct and the finished face of the framing member. Protective shield plates shall be constructed of steel, have a thickness of 0.062 inch (1.6 mm) and extend not less than 2 inches (51 mm) above sole plates and below top plates.))~~

[S] ((504.9) **504.8 Domestic clothes dryer ducts.** Exhaust ducts for domestic clothes dryers shall conform to the requirements of Sections ((504.9.1 through 504.9.6)) 504.8.1 through 504.8.6 and Section 504.2.1.

[S] ((504.9.1) **504.8.1 Material and size.** Exhaust ducts shall have a smooth interior finish and shall be constructed of metal not less than 0.016 inch (0.4 mm) in thickness. The exhaust duct size shall be 4 inches (102 mm) nominal in diameter.

[S] ((504.9.2) **504.8.2 Duct installation.** Exhaust ducts shall be supported at 4-foot (1219 mm) intervals and secured in place. The insert end of the duct shall extend into the adjoining duct or fitting in the direction of airflow. Ducts shall not be joined with screws or similar fasteners that protrude more than 1/8 inch (3.2 mm) into the inside of the duct.

Where dryer exhaust ducts are enclosed in wall or ceiling cavities, such cavities shall allow the installation of the duct without deformation.

[S] ((504.9.3) **504.8.3 Transition ducts.** Transition ducts used to connect the dryer to the exhaust duct system shall be a single length that is *listed* and *labeled* in accordance with UL 2158A. Transition ducts shall be not greater than 8 feet (2438 mm) in length and shall not be concealed within construction.

[S] ((504.9.4) **504.8.4 Duct length.** The maximum allowable exhaust duct length shall be determined by one of the methods specified in Sections ((504.9.4.1 through 504.9.4.3)) 504.8.4.1 and 504.8.4.2.

~~[S] ((504.9.4.1) **Specified length.** The maximum length of the exhaust duct shall be 35 feet (10 668 mm) from the connection to the transition duct from the dryer to the outlet terminal. Where fittings are used, the maximum length of the exhaust duct shall be reduced in accordance with Table 504.9.4.1.))~~

[S] TABLE ((504.9.4.1)) **504.8.4.1
DRYER EXHAUST DUCT FITTING EQUIVALENT LENGTH**

DRYER EXHAUST DUCT FITTING TYPE	EQUIVALENT LENGTH
4" radius mitered 45-degree elbow	2 feet 6 inches
4" radius mitered 90-degree elbow	5 feet
6" radius smooth 45-degree elbow	1 foot
6" radius smooth 90-degree elbow	1 foot 9 inches
8" radius smooth 45-degree elbow	1 foot
8" radius smooth 90-degree elbow	1 foot 7 inches
10" radius smooth 45-degree elbow	9 inches
10" radius smooth 90-degree elbow	1 foot 6 inches

For SI: 1 inch = 25.4 mm, 1 foot = 304.8 mm, 1 degree = 0.0175 rad.

[S] ((504.9.4.2) **504.8.1 Manufacturer's instructions.** The maximum length of the exhaust duct shall be determined by the dryer manufacturer's installation instructions. The code official shall be provided with a copy of the installation instructions for the make and model of the dryer. Where the exhaust duct is to be concealed, the installation instructions shall be provided to the code official prior to the concealment inspection. In the absence of fitting equivalent length calculations from the clothes dryer manufacturer, Table ((504.9.4.1)) 504.8.4.1 shall be used.

[S] ((504.9.4.3) **504.8.4.2 Dryer exhaust duct power ventilator length.** The maximum length of the exhaust duct shall be determined by the dryer exhaust duct power ventilator manufacturer's installation instructions.

[S] ((504.9.5) **504.8.5 Length identification.** Where the exhaust duct equivalent length exceeds 35 feet (10 668 mm), the equivalent length of the exhaust duct shall be identified on a permanent label or tag. The label or tag shall be located within 6 feet (1829 mm) of the exhaust duct connection.

[S] ((504.9.6) **504.8.6 Exhaust duct required.** Where space for a clothes dryer is provided, an exhaust duct system shall be installed. Where the clothes dryer is not installed at the time of occupancy, the exhaust duct shall be capped at the location of the future dryer.

Exception: Where a *listed* condensing clothes dryer is installed prior to occupancy of structure.

[S] ((504.10) **504.9 Commercial clothes dryers.** The installation of dryer exhaust ducts serving commercial clothes dryers shall comply with the *appliance* manufacturer's installation instructions. Exhaust fan motors installed in exhaust systems shall

be located outside of the airstream. In multiple installations, the fan shall operate continuously or be interlocked to operate when any individual unit is operating. Ducts shall have a minimum *clearance* of 6 inches (152 mm) to combustible materials. Clothes dryer transition ducts used to connect the *appliance* to the exhaust duct system shall be limited to single lengths not to exceed 8 feet (2438 mm) in length and shall be *listed* and *labeled* for the application. Transition ducts shall not be concealed within construction.

[W][S] ((504.11)) 504.10 Common exhaust systems for clothes dryers located in multistory structures. Where a common multistory duct system is designed and installed to convey exhaust from multiple clothes dryers, the construction of the system shall be in accordance with all of the following:

1. The shaft in which the duct is installed shall be constructed and fire-resistance rated as required by the *International Building Code*.
2. Dampers shall be prohibited in the exhaust duct. Penetrations of the shaft and ductwork shall be protected in accordance with Section 607.5.5, Exception 2.
3. Rigid metal ductwork shall be installed within the shaft to convey the exhaust. The ductwork shall be constructed of sheet steel having a minimum thickness of 0.0187 inch (0.4712 mm) (No. 26 gage) and in accordance with SMACNA Duct Construction Standards.
4. The ductwork within the shaft shall be designed and installed without offsets.
5. The exhaust fan motor design shall be in accordance with Section 503.2.
6. The exhaust fan motor shall be located outside of the airstream.
7. The exhaust fan shall run continuously, and shall be connected to a legally required standby power source.
8. Exhaust fan operation shall be monitored in an *approved* location and shall initiate an audible or visual signal when the fan is not in operation.
9. *Makeup air* shall be provided for the exhaust system to maintain the minimum flow for the exhaust fan when the dryers are not operating. Additionally, makeup air shall be provided when required by Section 504.7.
10. A cleanout opening shall be located at the base of the shaft to provide *access* to the duct to allow for cleaning and inspection. The finished opening shall be not less than 12 inches by 12 inches (305 mm by 305 mm).
11. Screens shall not be installed at the termination.
12. The common multistory duct system shall serve only clothes dryers and shall be independent of other exhaust systems.

SECTION 505 DOMESTIC COOKING EXHAUST EQUIPMENT

505.1 General. Domestic cooking exhaust *equipment* shall comply with the requirements of this section.

505.2 Domestic cooking exhaust. Where domestic cooking exhaust *equipment* is provided, it shall comply with the following as applicable:

1. The fan for overhead range hoods and downdraft exhaust *equipment* not integral with the cooking *appliance* shall be *listed* and *labeled* in accordance with UL 507.
2. Overhead range hoods and downdraft exhaust *equipment* with integral fans shall comply with UL 507.
3. Domestic cooking *appliances* with integral downdraft exhaust *equipment* shall be *listed* and *labeled* in accordance with UL 858 or ANSI Z21.1.
4. Microwave ovens with integral exhaust for installation over the cooking surface shall be *listed* and *labeled* in accordance with UL 923.

[W][S] 505.3 ((Exhaust)) Domestic cooking exhaust ducts. ((Domestic)) Ducts serving domestic cooking exhaust *equipment* shall discharge to the outdoors through sheet metal ducts constructed of galvanized steel, stainless steel, aluminum or copper. Such ducts shall have smooth inner walls, shall be airtight, ((and)) shall be equipped with a backdraft damper, and shall be independent of all other exhaust systems. Installations in Group I-1 and I-2 *occupancies* shall be in accordance with the *International Building Code* and Section 904.14 of the *International Fire Code*.

Domestic kitchen exhaust ducts may terminate with other domestic dryer exhaust and residential local exhaust ducts at a common location where each duct has an independent backdraft damper.

Listed and labeled exhaust booster fans shall be permitted when installed in accordance with the manufacturer's installation instructions.

Exceptions:

1. In other than Groups I-1 and I-2, where installed in accordance with the manufacturer's instructions and where ((mechanical or natural ventilation is otherwise provided in accordance with Chapter 4)) continuous local exhaust is

EXHAUST SYSTEMS

provided in an *enclosed kitchen* in accordance with Table 403.4.7, *listed* and *labeled* ductless range hoods shall not be required to discharge to the outdoors. The local exhaust from the residential dwelling or sleeping unit kitchen area may be combined with the local bathroom exhaust ductwork where the exhaust register/grille in the kitchen is a minimum of 6 feet from the domestic range cooktop. The exhaust register/grille shall be provided with a minimum MERV 3 filter or mesh filter (washable) for trapping grease.

Interpretation: Chapter 4 requires separate *local exhaust* systems in kitchens, including where ductless range hoods (also known as recirculating hoods) are used. Ductless range hoods are permitted in *dwelling units* where exhaust systems in the kitchen meet the requirements for *local exhaust*. In no case is *natural ventilation*, such as an operable window, allowed to substitute for the required kitchen *local exhaust* system.

2. Ducts for domestic kitchen cooking *appliances* equipped with downdraft exhaust systems shall be permitted to be constructed of Schedule 40 PVC pipe and fittings provided that the installation complies with all of the following:
 - 2.1. The duct shall be installed under a concrete slab poured on grade.
 - 2.2. The underfloor trench in which the duct is installed shall be completely backfilled with sand or gravel.
 - 2.3. The PVC duct shall extend not more than 1 inch (25 mm) above the indoor concrete floor surface.
 - 2.4. The PVC duct shall extend not more than 1 inch (25 mm) above grade outside of the building.
 - 2.5. The PVC ducts shall be solvent cemented.

505.4 Makeup air required Exhaust hood systems capable of exhausting in excess of 400 cfm (0.19 m³/s) shall be provided with *makeup air* at a rate approximately equal to the *exhaust air* rate. Such *makeup air* systems shall be equipped with a means of closure and shall be automatically controlled to start and operate simultaneously with the exhaust system.

[S] 505.5 Common exhaust systems for domestic kitchens located in multistory structures. Where a common multistory duct system is designed and installed to convey exhaust from multiple domestic kitchen exhaust systems, the construction of the system shall be in accordance with all of the following:

1. The shaft in which the duct is installed shall be constructed and fire-resistance rated as required by the *International Building Code*.
2. Dampers shall be prohibited in the exhaust duct, except as specified in Section 505.3. Penetrations of the shaft and ductwork shall be protected in accordance with Section 607.5.5, Exception 2.
3. Rigid metal ductwork shall be installed within the shaft to convey the exhaust. The ductwork shall be constructed of sheet steel having a minimum thickness of 0.0187 inch (0.4712 mm) (No. 26 gage) and in accordance with SMACNA Duct Construction Standards.
4. The ductwork within the shaft shall be designed and installed without offsets.
5. The exhaust fan motor design shall be in accordance with Section 503.2.
6. The exhaust fan motor shall be located outside of the airstream.
7. The exhaust fan shall run continuously, and shall be connected to a standby power source.
8. Exhaust fan operation shall be monitored in an approved location and shall initiate an audible or visual signal when the fan is not in operation.
9. Where the exhaust rate for an individual kitchen exceeds 400 cfm (0.19 m³/s) *makeup air* shall be provided in accordance with Section 505.4.
10. A cleanout opening shall be located at the base of the shaft to provide access to the duct to allow for cleanout and inspection. The finished openings shall be not less than 12 inches by 12 inches (305 mm by 305 mm).
11. Screens shall not be installed at the termination.
12. The common multistory duct system shall serve only kitchen exhaust and shall be independent of other exhaust systems.

Exception: Where labeled ductless range hoods are provided the local exhaust from the residential dwelling or sleeping unit kitchen area may be combined with the local bathroom exhaust ductwork where the exhaust register/grille in the kitchen is a minimum of 6 feet from the domestic range cooktop. The exhaust register/grille shall be provided with a minimum MERV 3 filter or mesh filter (washable) for trapping grease.

505.6 Other than Group R. In other than Group R *occupancies*, where domestic cooktops, ranges, and open-top broilers are used for domestic purposes, domestic cooking exhaust systems shall be provided.

EXHAUST SYSTEMS

[W] **506.3.2.4 Vibration isolation.** A vibration isolation connector for connecting a duct to a fan shall consist of noncombustible packing in a metal sleeve joint of *approved* design or shall be a coated-fabric flexible duct connector (~~*listed and labeled for the application*~~) rated for continuous duty at temperature of not less than 1500°F (816°C). Vibration isolation connectors shall be installed only at the connection of a duct to a fan inlet or outlet.

506.3.2.5 Grease duct test. Prior to the use or concealment of any portion of a grease duct system, a leakage test shall be performed. Ducts shall be considered to be concealed where installed in shafts or covered by coatings or wraps that prevent the ductwork from being visually inspected on all sides. The permit holder shall be responsible to provide the necessary *equipment* and perform the grease duct leakage test. A light test shall be performed to determine that all welded and brazed joints are liquid tight.

A light test shall be performed by passing a lamp having a power rating of not less than 100 watts through the entire section of ductwork to be tested. The lamp shall be open so as to emit light equally in all directions perpendicular to the duct walls. A test shall be performed for the entire duct system, including the hood-to-duct connection. The duct work shall be permitted to be tested in sections, provided that every joint is tested. For *listed* factory-built grease ducts, this test shall be limited to duct joints assembled in the field and shall exclude factory welds.

506.3.3 Grease duct supports. Grease duct bracing and supports shall be of noncombustible material securely attached to the structure and designed to carry gravity and seismic loads within the stress limitations of the *International Building Code*. Bolts, screws, rivets and other mechanical fasteners shall not penetrate duct walls.

506.3.4 Air velocity. Grease duct systems serving a Type I hood shall be designed and installed to provide an air velocity within the duct system of not less than 500 feet per minute (2.5 m/s).

Exception: The velocity limitations shall not apply within duct transitions utilized to connect ducts to differently sized or shaped openings in hoods and fans, provided that such transitions do not exceed 3 feet (914 mm) in length and are designed to prevent the trapping of grease.

[S] **506.3.5 Separation of grease duct system.** A separate grease duct system shall be provided for each Type I hood. (~~A separate grease duct system is not required~~) Multiple Type I hoods are permitted to be combined where all of the following conditions are met:

1. All interconnected hoods are located within the same story.
2. All interconnected hoods are located within the same room or in adjoining rooms.
3. Interconnecting ducts do not penetrate assemblies required to be fire-resistance rated.
4. The grease duct system does not serve solid-fuel-fired *appliances*.

506.3.6 Grease duct clearances. Where enclosures are not required, grease duct systems and exhaust *equipment* serving a Type I hood shall have a *clearance* to combustible construction of not less than 18 inches (457 mm), and shall have a *clearance* to noncombustible construction and gypsum wallboard attached to noncombustible structures of not less than 3 inches (76 mm).

Exceptions:

1. Factory-built commercial kitchen grease ducts *listed and labeled* in accordance with UL 1978.
2. *Listed and labeled* exhaust *equipment* installed in accordance with Section 304.1.
3. Where commercial kitchen grease ducts are continuously covered on all sides with a *listed and labeled* field-applied grease duct enclosure material, system, product or method of construction specifically evaluated for such purpose in accordance with ASTM E2336, the required *clearance* shall be in accordance with the listing of such material, system, product or method.

[S] **506.3.7 Prevention of grease accumulation in grease ducts.** Duct systems serving a Type I hood shall be constructed and installed so that grease cannot collect in any portion thereof, and the system shall slope not less than 1/4 unit vertical in 12 units horizontal (2-percent slope) toward the hood or toward a grease reservoir designed and installed in accordance with Section 506.3.7.1. Where horizontal ducts exceed 75 feet (22 860 mm) in length, the slope shall be not less than 1 unit vertical in 12 units horizontal (8.3-percent slope). Obstructions in the ductwork, such as duct-mounted sound attenuators or perforated acoustical louvers, are required to be listed and labeled per NFPA 96, UL 1978, or other applicable standard approved by the code official.

Exception: Factory-built grease ducts shall be installed at a slope that is in accordance with the listing and manufacturer's installation instructions.

506.3.7.1 Grease duct reservoirs. Grease duct reservoirs shall:

1. Be constructed as required for the grease duct they serve.
2. Be located on the bottom of the horizontal duct or the bottommost section of the duct riser.
3. Extend across the full width of the duct and have a length of not less than 12 inches (305 mm).

4. Have a depth of not less than 1 inch (25 mm).
5. Have a bottom that slopes to a drain.
6. Be provided with a cleanout opening constructed in accordance with Section 506.3.8 and installed to provide direct access to the reservoir. The cleanout opening shall be located on a side or on top of the duct so as to permit cleaning of the reservoir.
7. Be installed in accordance with the manufacturer's instructions where manufactured devices are utilized.

506.3.8 Grease duct cleanouts and openings. Grease duct cleanouts and openings shall comply with all of the following:

1. Grease ducts shall not have openings except where required for the operation and maintenance of the system.
2. Sections of grease ducts that are inaccessible from the hood or discharge openings shall be provided with cleanout openings spaced not more than 20 feet (6096 mm) apart and not more than 10 feet (3048 mm) from changes in direction greater than 45 degrees (0.79 rad).
3. Cleanouts and openings shall be equipped with tight-fitting doors constructed of steel having a thickness not less than that required for the duct.
4. Cleanout doors shall be installed liquid tight.
5. Door assemblies including any frames and gaskets shall be approved for the application and shall not have fasteners that penetrate the duct.
6. Gasket and sealing materials shall be rated for not less than 1,500°F (816°C).
7. Listed door assemblies shall be installed in accordance with the manufacturer's instructions.

506.3.8.1 Personnel entry. Where ductwork is large enough to allow entry of personnel, not less than one *approved* or *listed* opening having dimensions not less than 22 inches by 20 inches (559 mm by 508 mm) shall be provided in the horizontal sections, and in the top of vertical risers. Where such entry is provided, the duct and its supports shall be capable of supporting the additional load, and the cleanouts specified in Section 506.3.8 are not required.

506.3.8.2 Cleanouts serving in-line fans. A cleanout shall be provided for both the inlet side and outlet side of an in-line fan except where a duct does not connect to the fan. Such cleanouts shall be located within 3 feet (914 mm) of the fan duct connections.

[S] 506.3.9 Grease duct cleanout location, spacing and installation.

506.3.9.1 Grease duct horizontal cleanouts. Cleanouts serving horizontal sections of grease ducts shall:

1. Be spaced not more than 20 feet (6096 mm) apart.
2. Be located not more than 10 feet (3048 mm) from changes in direction that are greater than 45 degrees (0.79 rad).
3. Be located on the bottom only where other locations are not available and shall be provided with internal damming of the opening such that grease will flow past the opening without pooling. Bottom cleanouts and openings shall be approved for the application and installed liquid tight.
4. Not be closer than 1 inch (25 mm) from the edges of the duct.
5. Have opening dimensions of not less than 12 inches by 12 inches (305 mm by 305 mm). Where such dimensions preclude installation, the openings shall be not less than 12 inches (305 mm) on one side and shall be large enough to provide access for cleaning and maintenance.
6. Be located at grease reservoirs.
7. Be located within 3 feet (914 mm) of horizontal discharge fans.

[W][S] 506.3.9.2 Grease duct vertical cleanouts. Where ducts pass vertically through floors, cleanouts shall be provided. A minimum of one cleanout shall be provided on each floor. Cleanout openings shall be not less than 1-1/2 inches (38 mm) from all outside edges of the duct or welded seams. The opening minimum dimensions shall be 12 inches (305 mm) on each side.

506.3.10 Underground grease duct installation. Underground grease duct installations shall comply with all of the following:

1. Underground grease ducts shall be constructed of steel having a minimum thickness of 0.0575 inch (1.463 mm) (No. 16 gage) and shall be coated to provide protection from corrosion or shall be constructed of stainless steel having a minimum thickness of 0.0450 inch (1.140 mm) (No. 18 gage).
2. The underground duct system shall be tested and approved in accordance with Section 506.3.2.5 prior to coating or placement in the ground.
3. The underground duct system shall be completely encased in concrete with a minimum thickness of 4 inches (102 mm).
4. Ducts shall slope toward grease reservoirs.

EXHAUST SYSTEMS

5. A grease reservoir with a cleanout to allow cleaning of the reservoir shall be provided at the base of each vertical duct riser.
6. Cleanouts shall be provided with access to permit cleaning and inspection of the duct in accordance with Section 506.3.
7. Cleanouts in horizontal ducts shall be installed on the topside of the duct.
8. Cleanout locations shall be legibly identified at the point of access from the interior space.

[W][S] 506.3.11 Grease duct enclosures. A commercial kitchen grease duct serving a Type I hood that penetrates a ceiling, wall, floor or any concealed spaces shall be enclosed from the point of penetration to the outlet terminal. In-line exhaust fans not located outdoors shall be enclosed as required for grease ducts. A duct shall penetrate exterior walls only at locations where unprotected openings are permitted by the *International Building Code*. The duct enclosure shall serve a single grease duct and shall not contain other ducts, piping or wiring systems. Duct enclosures shall be a shaft enclosure in accordance with Section 506.3.11.1, a field-applied enclosure assembly in accordance with Section 506.3.11.2 or a factory-built enclosure assembly in accordance with Section 506.3.11.3. Duct enclosures shall have a fire-resistance rating of not less than that of the assembly penetrated, ~~(and not less than 1 hour.)~~ The duct enclosure need not exceed 2 hours but shall not be less than 1 hour. Fire dampers and smoke dampers shall not be installed in grease ducts.

Exceptions:

1. A duct enclosure shall not be required for a grease duct that penetrates only a nonfire-resistance-rated roof/ceiling assembly.
2. In buildings that are designed in accordance with *International Building Code* Section 510.2, grease duct enclosures that penetrate the 3-hour horizontal assembly are permitted to be protected in accordance with the exception to Section 510.2 Item 3.

506.3.11.1 Shaft enclosure. Grease ducts constructed in accordance with Section 506.3.1 shall be permitted to be enclosed in accordance with the *International Building Code* requirements for shaft construction. Such grease duct systems and exhaust equipment shall have a clearance to combustible construction of not less than 18 inches (457 mm), and shall have a clearance to noncombustible construction and gypsum wallboard attached to noncombustible structures of not less than 6 inches (152 mm). Duct enclosures shall be sealed around the duct at the point of penetration and vented to the outside of the building through the use of weather-protected openings.

Interpretation: Gypsum wallboard installed on a combustible substrate or on wood studs does not cause the wall to be considered as a noncombustible assembly, and the 18 inch minimum clearance still applies. The classification of combustible and noncombustible materials is not changed by the use of fire-retardant-treated wood products or fire rated (Type "X") gypsum wallboard.

506.3.11.2 Field-applied grease duct enclosure. Grease ducts constructed in accordance with Section 506.3.1 shall be enclosed by a *listed* and *labeled* field-applied grease duct enclosure material, systems, product, or method of construction specifically evaluated for such purpose in accordance with ASTM E2336. The surface of the duct shall be continuously covered on all sides from the point at which the duct originates to the outlet terminal. Duct penetrations shall be protected with a through-penetration firestop system tested and *listed* in accordance with ASTM E814 or UL 1479 and having a "F" and "T" rating equal to the fire-resistance rating of the assembly being penetrated. The grease duct enclosure and firestop system shall be installed in accordance with the listing and the manufacturer's instructions. Partial application of a field-applied grease duct enclosure shall not be installed for the sole purpose of reducing clearances to combustibles at isolated sections of grease duct. Exposed duct-wrap systems shall be protected where subject to physical damage.

506.3.11.3 Factory-built grease duct enclosure assemblies. Factory-built grease ducts incorporating integral enclosure materials shall be *listed* and *labeled* for use as grease duct enclosure assemblies specifically evaluated for such purpose in accordance with UL 2221. Duct penetrations shall be protected with a through-penetration firestop system tested and *listed* in accordance with ASTM E814 or UL 1479 and having an "F" and "T" rating equal to the fire-resistance rating of the assembly being penetrated. The grease duct enclosure assembly and firestop system shall be installed in accordance with the listing and the manufacturer's instructions.

506.3.12 Grease duct fire-resistive access opening. Where cleanout openings are located in ducts within a fire-resistance-rated enclosure, access openings shall be provided in the enclosure at each cleanout point. Access openings shall be equipped with tight-fitting sliding or hinged doors that are equal in fire-resistive protection to that of the shaft or enclosure. An *approved* sign shall be placed on access opening panels with wording as follows: "ACCESS PANEL. DO NOT OBSTRUCT."

506.3.13 Exhaust outlets serving Type I hoods. Exhaust outlets for grease ducts serving Type I hoods shall conform to the requirements of Sections 506.3.13.1 through 506.3.13.3.

506.3.13.1 Termination above the roof. Exhaust outlets that terminate above the roof shall have the discharge opening located not less than 40 inches (1016 mm) above the roof surface.

[S] 506.3.13.2 Termination through an exterior wall. Exhaust outlets shall be permitted to terminate through exterior walls where the smoke, grease, gases, vapors and odors in the discharge from such terminations do not create a public nuisance or a fire hazard. The installation of a pollution control unit in conjunction with an exhaust outlet shall be an approved method of eliminating smoke, grease, vapors and odors from discharging to the exterior. Such terminations shall not be located where protected openings are required by the *International Building Code*. Such terminations shall be located in accordance with Section 506.3.13.3 and shall not be located within 3 feet (914 mm) of any opening in the exterior wall except non-openable windows glazed with tempered or wired glass. The discharge outlets shall be not less than 10 feet (3.048 m) above the sidewalk or other walks, drives, streets or alleys. No portion of an exhaust outlet shall protrude into a public place less than 16 feet (4.876 m) above the ground. Whenever any portion of the exhaust outlet or duct protrudes beyond the property line over a public place, it is subject to the permit requirements of the Seattle Department of Transportation.

Note: See Director's Rule for the conditions where Type I hoods that are part of small commercial kitchen exhaust systems in taller buildings may be permitted to terminate at an exterior wall.

506.3.13.3 Termination location. Exhaust outlets shall be located not less than 10 feet (3048 mm) horizontally from parts of the same or contiguous buildings, adjacent buildings and adjacent property lines and shall be located not less than 10 feet (3048 mm) above the adjoining grade level. Exhaust outlets shall be located not less than 10 feet (3048 mm) horizontally from or not less than 3 feet (914 mm) above air intake openings into any building.

Exception: Exhaust outlets shall terminate not less than 5 feet (1524 mm) horizontally from parts of the same or contiguous building, an adjacent building, adjacent property line and air intake openings into a building where air from the exhaust outlet discharges away from such locations.

[S] 506.4 Ducts serving Type II hoods. Commercial kitchen exhaust systems serving Type II hoods shall comply with Sections 506.4.1 and 506.4.2.

Interpretation: For purposes of this section, property line includes any property line separating one lot from another lot, but does not include any property line separating a lot from a public street or alley right-of-way.

506.4.1 Ducts. Ducts and *plenums* serving Type II hoods shall be constructed of rigid metallic materials. Duct construction, installation, bracing and supports shall comply with Chapter 6. A duct serving a Type II hood that penetrates a fire-resistance-rated ceiling, floor or wall shall be in a rated enclosure from the point of penetration to the outlet with a rating equal to the fire-resistance rating of the assembly being penetrated. Ducts subject to positive pressure and ducts conveying moisture-laden or waste-heat-laden air shall be constructed, joined and sealed in an *approved* manner.

506.4.2 Type II terminations. Exhaust outlets serving Type II hoods shall terminate in accordance with the hood manufacturer's installation instructions and shall comply with all of the following:

1. Exhaust outlets shall terminate not less than 3 feet (914 mm) in any direction from openings into the building.
2. Outlets shall terminate not less than 10 feet (3048 mm) from property lines or buildings on the same lot.
3. Outlets shall terminate not less than 10 feet (3048 mm) above grade.
4. Outlets that terminate above a roof shall terminate not less than 30 inches (762 mm) above the roof surface.
5. Outlets shall terminate not less than 30 inches (762 mm) from exterior vertical walls.
6. Outlets shall be protected against local weather conditions.
7. Outlets shall not be directed onto walkways.
8. Outlets shall meet the provisions for exterior wall opening protectives in accordance with the *International Building Code*.

506.5 Exhaust equipment. Exhaust *equipment*, including fans and grease reservoirs, shall comply with Sections 506.5.1 through 506.5.6 and shall be of an *approved* design or shall be *listed* for the application.

506.5.1 Exhaust fans. Exhaust fan housings serving a Type I hood shall be constructed as required for grease ducts in accordance with Section 506.3.1.1.

Exception: Fans *listed* and *labeled* in accordance with UL 762.

506.5.1.1 Fan motor. Exhaust fan motors shall be located outside of the exhaust airstream.

506.5.1.2 In-line fan location. Where enclosed duct systems are connected to in-line fans not located outdoors, the fan shall be located in a room or space having the same fire-resistance rating as the duct enclosure. Access shall be provided

SECTION 507 COMMERCIAL KITCHEN HOODS

[S] **507.1 General.** Commercial kitchen exhaust hoods shall comply with the requirements of this section. Hoods shall be Type I or II and shall be designed to capture and confine cooking vapors and residues. A Type I or Type II hood shall be installed at or above *appliances* in accordance with Sections 507.2 and 507.3 and Table 507.2.1. Where any cooking *appliance* under a single hood requires a Type I hood, a Type I hood shall be installed. Where a Type II hood is required, a Type I or Type II hood shall be installed. Where a Type I hood is installed, the installation of the entire system, including the hood, ducts, exhaust *equipment* and *makeup air* system shall comply with the requirements of Sections 506, 507, 508 and 509.

Exceptions:

1. Factory-built commercial exhaust hoods that are *listed* and *labeled* in accordance with UL 710, and installed in accordance with Section 304.1, shall not be required to comply with Sections 507.1.5, 507.2.3, 507.2.5, 507.2.8, 507.3.1, 507.3.3, 507.4 and 507.5.
2. Factory-built commercial cooking recirculating systems that are *listed* and *labeled* in accordance with UL 710B, and installed in accordance with Section 304.1, shall not be required to comply with Sections 507.1.5, 507.2.3, 507.2.5, 507.2.8, 507.3.1, 507.3.3, 507.4 and 507.5. Spaces in which such systems are located shall be considered to be kitchens and shall be ventilated in accordance with Table 403.3.1.1. The kitchen exhaust system shall discharge in accordance with Section 501.3.1, item 3. For the purpose of determining the floor area required to be ventilated, each individual *appliance* shall be considered as occupying not less than 100 square feet (9.3 m²).
3. Where cooking *appliances* are equipped with integral down-draft exhaust systems and such *appliances* and exhaust systems are *listed* and *labeled* for the application in accordance with NFPA 96, a hood shall not be required at or above them.
4. Smoker ovens with integral exhaust systems, provided that the *appliance* is installed in accordance with the manufacturer's installation instructions, is listed and tested for the application, and complies with Chapter 5.

507.1.1 Operation. Commercial kitchen exhaust hood systems shall operate during the cooking operation. The hood exhaust rate shall comply with the listing of the hood or shall comply with Section 507.5. The exhaust fan serving a Type I hood shall have automatic controls that will activate the fan when any *appliance* that requires such Type I hood is turned on, or a means of interlock shall be provided that will prevent operation of such *appliances* when the exhaust fan is not turned on. Where one or more temperature or radiant energy sensors are used to activate a Type I hood exhaust fan, the fan shall activate not more than 15 minutes after the first *appliance* served by that hood has been turned on. A method of interlock between an exhaust hood system and *appliances* equipped with standing pilot burners shall not cause the pilot burners to be extinguished. A method of interlock between an exhaust hood system and cooking *appliances* shall not involve or depend on any component of a fire-extinguishing system.

The net exhaust volumes for hoods shall be permitted to be reduced during part-load cooking conditions, where engineered or *listed* multispeed or variable speed controls automatically operate the exhaust system to maintain capture and removal of cooking effluents as required by this section. Reduced volumes shall not be below that required to maintain capture and removal of effluents from the idle cooking *appliances* that are operating in a standby mode.

507.1.1.1 Multiple hoods utilizing a single exhaust system. Where heat or radiant energy sensors are utilized in hood systems consisting of multiple hoods served by a single exhaust system, such sensors shall be provided in each hood. Sensors shall be capable of being accessed from the hood outlet or from a cleanout location.

507.1.2 Domestic cooking appliances used for commercial purposes. Domestic cooking *appliances* utilized for commercial purposes shall be provided with Type I, ~~((or))~~ Type II or residential hoods ~~((as required for the type of appliances and processes))~~ in accordance with Sections 507.2 and 507.3 and Table 507.1.2. Domestic cooking *appliances* utilized for domestic cooking shall comply with Section 505.

EXHAUST SYSTEMS

**[W] [S] TABLE 507.1.2
TYPE OF HOOD REQUIRED FOR DOMESTIC COOKING APPLIANCES^{1,2}**

TYPE OF SPACE ³	TYPE OF COOKING	TYPE OF HOOD
Places of Religious Worship	1) Boiling, steaming and warming precooked food	Type II
	2) Roasting, pan frying and deep frying	Type I
Community or party room in apartment and condominium	1) Boiling, steaming and warming precooked food	Residential hood ⁴ or Type II ⁵
	2) Roasting, pan frying and deep frying	Type I
Day care	1) Boiling, steaming and warming precooked food	Residential hood ⁴ or Type II ⁵
	2) Roasting, pan frying and deep frying	Type I
Dormitory, boarding home, nursing home	1) Boiling, steaming and warming precooked food	Type II
	2) Roasting, pan frying and deep frying	Type I
Office lunch room	1) Boiling, steaming and warming precooked food	Residential hood ⁴ or Type II ⁵
	2) Roasting, pan frying and deep frying	Type I

¹ Commercial cooking appliances shall comply with Section 507.2.

² Requirements in this table apply to electric or gas fuel appliances only. Solid fuel appliances or charbroilers require Type I hoods.

³ The code official shall determine hood requirements for other types of spaces.

⁴ Residential hood shall vent to outside.

⁵ A Type II hood is required when the combined capacity of cooking appliances is more than 6 kW.

507.1.3 Fuel-burning appliances. Where vented fuel-burning *appliances* are located in the same room or space as the hood, provisions shall be made to prevent the hood system from interfering with normal operation of the *appliance* vents.

507.1.4 Cleaning. A hood shall be designed to provide for thorough cleaning of the entire hood.

507.1.5 Exhaust outlets. Exhaust outlets located within the hood shall be located so as to optimize the capture of particulate matter. Each outlet shall serve not more than a 12-foot (3658 mm) section of hood.

[S] 507.2 Type I hoods. Type I hoods shall be installed where cooking *appliances* produce grease or smoke as a result of the cooking process. Type I hoods shall be installed over *medium-duty, heavy-duty* and *extra-heavy-duty* cooking *appliances*.

Exceptions:

1. A Type I hood shall not be required for an electric cooking *appliance* where an approved testing agency provides documentation that the *appliance* effluent contains 5 mg/m³ or less of grease when tested at an exhaust flow rate of 500 cfm (0.236 m³/s) in accordance with UL 710B.
2. A Type I hood shall not be required in an R-2 an *occupancy* with not more than 16 residents.

507.2.1 Type I exhaust flow rate label. Type I hoods shall bear a label indicating the minimum exhaust flow rate in cfm per linear foot (1.55 L/s per linear meter) of hood that provides for capture and containment of the exhaust effluent for the cooking *appliances* served by the hood, based on the cooking *appliance* duty classifications defined in this code.

**[S] TABLE 507.2.1
TYPE OF HOOD REQUIRED FOR COMMERCIAL COOKING APPLIANCES**

TYPE OF APPLIANCE ^{1,2}	TYPE OF HOOD REQUIRED ²		
	TYPE I ³	TYPE II	NONE ⁴
Baking oven	Solid fuel	> 6 kW	≤ 6 kW
Charbroiler	All sizes		
Coffee maker		> 12 kW	≤ 12 kW
Coffee roaster ⁴		All sizes	
Convection ovens (electric)		> 6 kW	≤ 6 kW
Deep-fat fryer	All sizes		
Dishwasher		> 140°F	≤ 140°F
Grill	All sizes		
Hot dog display heater		> 6 kW	≤ 6 kW
Microwave oven			All sizes
Pastry oven		> 6 kW	≤ 6 kW
Pizza oven	Solid fuel	> 6 kW	≤ 6 kW
Popcorn maker		> 6 kW	≤ 6 kW
Roasting oven ⁵	> 6 kW	≤ 6 kW	
Roll warmer		> 6 kW	≤ 6 kW

**[S] TABLE 507.2.1—continued
TYPE OF HOOD REQUIRED FOR COMMERCIAL COOKING APPLIANCES**

TYPE OF APPLIANCE ^{1,2}	TYPE OF HOOD REQUIRED ²		
	TYPE I ³	TYPE II	NONE ⁴
Solid-fuel burning appliances	All sizes & all food products		
Soup warmer, soup preparation cooking unit		> 6 kW	≤ 6 kW
Steam reconstitution device		> 6 kW	≤ 6 kW
Steam table		> 6 kW	≤ 6 kW
Steamer		> 6 kW	≤ 6 kW
Toaster		> 6 kW	≤ 6 kW
Warming oven		> 6 kW	≤ 6 kW

1. The code official shall determine hood requirements for appliances not listed in the table.
2. Section 507.2 describes Type I and Type II kitchen hoods.
3. The definition of extra-heavy-duty cooking appliance includes all appliances utilizing solid fuel.
4. Puget Sound Clean Air Agency requires an after-burner for most coffee roasters to decrease particulates. See pscleanair.gov for more details.
5. Roasting ovens are used to cook raw or partially cooked food.
6. Where a cooking appliance is installed without hood under Section 507.1 exception or Table 507.2.1, general kitchen exhaust shall be required per Section 507.3.
7. A Type II hood is required when the combined capacity of cooking appliances, other than coffee makers, is more than 12 kW.

507.2.2 Type I extra-heavy-duty. Type I hoods for use over *extra-heavy-duty cooking appliances* shall not cover *heavy-, medium- or light-duty appliances*. Such hoods shall discharge to an exhaust system that is independent of other exhaust systems.

507.2.3 Type I materials. Type I hoods shall be constructed of steel having a minimum thickness of 0.0466 inch (1.181 mm) (No. 18 gage) or stainless steel not less than 0.0335 inch [0.8525 mm (No. 20 MSG)] in thickness.

507.2.4 Type I supports. Type I hoods shall be secured in place by noncombustible supports. Type I hood supports shall be adequate for the applied load of the hood, the unsupported ductwork, the effluent loading and the possible weight of personnel working in or on the hood.

507.2.5 Type I hoods. External hood joints, seams and penetrations for Type I hoods shall be made with a continuous external liquid-tight weld or braze to the lowest outermost perimeter of the hood. Internal hood joints, seams, penetrations, filter support frames and other appendages attached inside the hood shall not be required to be welded or brazed but shall be otherwise sealed to be grease tight.

Exceptions:

1. Penetrations shall not be required to be welded or brazed where sealed by devices that are *listed* for the application.
2. Internal welding or brazing of seams, joints and penetrations of the hood shall not be prohibited provided that the joint is formed smooth or ground so as to not trap grease, and is readily cleanable.

507.2.6 Clearances for Type I hood. A Type I hood shall be installed with a *clearance* to combustibles of not less than 18 inches (457 mm).

Exceptions:

1. *Clearance* shall not be required from gypsum wallboard or 1/2-inch (12.7 mm) or thicker cementitious wallboard attached to noncombustible structures provided that a smooth, cleanable, nonabsorbent and noncombustible material is installed between the hood and the gypsum or cementitious wallboard over an area extending not less than 18 inches (457 mm) in all directions from the hood.

Interpretation: Gypsum wallboard installed on a combustible substrate or on wood studs does not cause the wall to be considered a noncombustible assembly, and the 18 inch minimum *clearance* still applies. The classification of combustible and noncombustible materials is not changed by the use of fire-retardant-treated wood products or fire rated (Type “X”) gypsum wallboard.

2. Type I hoods *listed* and *labeled* for *clearances* less than 18 inches (457 mm) in accordance with UL 710 shall be installed with the *clearances* specified by such listings.

507.2.7 Type I hoods penetrating a ceiling. Type I hoods or portions thereof penetrating a ceiling, wall or furred space shall comply with Section 506.3.11. Field-applied grease duct enclosure systems, as addressed in Section 506.3.11.2, shall not be utilized to satisfy the requirements of this section.

EXHAUST SYSTEMS

Exception: The exhaust hood may penetrate the plane of the adjacent ceiling without a rated enclosure when the ceiling is a minimum of 18" from the hood and the area above the ceiling is separated from a plenum.

507.2.8 Type I grease filters. Type I hoods shall be equipped with grease filters *listed* and *labeled* in accordance with UL 1046. Grease filters shall be provided with access for cleaning or replacement. The lowest edge of a grease filter located above the cooking surface shall be not less than the height specified in Table 507.2.8.

**TABLE 507.2.8
MINIMUM DISTANCE BETWEEN THE LOWEST EDGE OF A GREASE FILTER
AND THE COOKING SURFACE OR THE HEATING SURFACE**

TYPE OF COOKING APPLIANCES	HEIGHT ABOVE COOKING SURFACE (feet)
Without exposed flame	0.5
Exposed flame and burners	2
Exposed charcoal and charbroil type	3.5

For SI: 1 foot = 304.8 mm.

507.2.8.1 Criteria. Filters shall be of such size, type and arrangement as will permit the required quantity of air to pass through such units at rates not exceeding those for which the filter or unit was designed or *approved*. Filter units shall be installed in frames or holders so as to be readily removable without the use of separate tools, unless designed and installed to be cleaned in place and the system is equipped for such cleaning in place. Where filters are designed and required to be cleaned, removable filter units shall be of a size that will allow them to be cleaned in a dishwashing machine or pot sink. Filter units shall be arranged in place or provided with drip-intercepting devices to prevent grease or other condensate from dripping into food or on food preparation surfaces.

507.2.8.2 Mounting position of grease filters. Filters shall be installed at an angle of not less than 45 degrees (0.79 rad) from the horizontal and shall be equipped with a drip tray beneath the lower edge of the filters.

507.2.9 Grease gutters for Type I hood. Grease gutters shall drain to an *approved* collection receptacle that is fabricated, designed and installed to allow access for cleaning.

[S] 507.3 Type II hoods. Type II hoods shall be installed (~~above~~) for collecting and removing steam, vapor, heat or odors from dishwashers and *appliances* that produce heat or moisture and do not produce grease or smoke as a result of the cooking process, except where the heat and moisture loads from such *appliances* are incorporated into the HVAC system design or into the design of a separate removal system. Type II hoods shall be installed (~~above~~) for collecting and removing steam, vapor, heat or odors from all *appliances* that produce products of combustion and do not produce grease or smoke as a result of the cooking process. Spaces containing cooking *appliances* that do not require Type II hoods shall be provided with exhaust at a rate of 0.70 cfm per square foot (0.00356 m³/(s • m²)). For the purpose of determining the floor area required to be exhausted, each individual *appliance* that is not required to be installed under a Type II hood shall be considered as occupying not less than 100 square feet (9.3 m²). Such additional square footage shall be provided with exhaust at a rate of 0.70 cfm per square foot [0.00356 m³/(s • m²)].

507.3.1 Type II hood materials. Type II hoods shall be constructed of steel having a minimum thickness of 0.0296 inch (0.7534 mm) (No. 22 gage) or stainless steel not less than 0.0220 inch (0.5550 mm) (No. 24 gage) in thickness, copper sheets weighing not less than 24 ounces per square foot (7.3 kg/m²) or of other *approved* material and gage.

507.3.2 Type II supports. Type II hood supports shall be adequate for the applied load of the hood, the unsupported ductwork, the effluent loading and the possible weight of personnel working in or on the hood.

507.3.3 Type II hoods joint, seams and penetrations. Joints, seams and penetrations for Type II hoods shall be constructed as set forth in Chapter 6, shall be sealed on the interior of the hood and shall provide a smooth surface that is readily cleanable and watertight.

507.4 Hood size and location. Hoods shall comply with the overhang, setback and height requirements in accordance with Sections 507.4.1 and 507.4.2, based on the type of hood.

507.4.1 Canopy size and location. The inside lower edge of canopy-type Type I and II commercial hoods shall overhang or extend a horizontal distance of not less than 6 inches (152 mm) beyond the edge of the top horizontal surface of the *appliance* on all open sides. The vertical distance between the front lower lip of the hood and such surface shall not exceed 4 feet (1219 mm).

Exception: The hood shall be permitted to be flush with the outer edge of the cooking surface where the hood is closed to the *appliance* side by a noncombustible wall or panel.

507.4.2 Noncanopy size and location. Noncanopy-type hoods shall be located not greater than 3 feet (914 mm) above the cooking surface. The edge of the hood shall be set back not greater than 1 foot (305 mm) from the edge of the cooking surface.

507.5 Capacity of hoods. Commercial food service hoods shall exhaust a minimum net quantity of air determined in accordance with this section and Sections 507.5.1 through 507.5.5. The net quantity of *exhaust air* shall be calculated by subtracting any airflow supplied directly to a hood cavity from the total exhaust flow rate of a hood. Where any combination of *heavy-duty*, *medium-duty* and *light-duty cooking appliances* are utilized under a single hood, the exhaust rate required by this section for the heaviest duty *appliance* covered by the hood shall be used for the entire hood.

[S] 507.5.1 Extra-heavy-duty (solid fuel) cooking appliances. The minimum net airflow for hoods, as determined by Section 507.1, used for *extra-heavy-duty cooking appliances* shall be determined as follows:

Type of Hood	CFM per linear foot of hood
Backshelf/pass-over	Not allowed
Double island canopy (per side)	550
Eyebrow	Not allowed
Single island canopy	700
Wall-mounted canopy	550

For SI: 1 cfm per linear foot = 1.55 L/s per linear meter.

507.5.2 Heavy-duty cooking appliances. The minimum net airflow for hoods, as determined by Section 507.1, used for *heavy-duty cooking appliances* shall be determined as follows:

Type of Hood	CFM per linear foot of hood
Backshelf/pass-over	400
Double island canopy (per side)	400
Eyebrow	Not allowed
Single island canopy	600
Wall-mounted canopy	400

For SI: 1 cfm per linear foot = 1.55 L/s per linear meter.

507.5.3 Medium-duty cooking appliances. The minimum net airflow for hoods, as determined by Section 507.1, used for *medium-duty cooking appliances* shall be determined as follows:

Type of Hood	CFM per linear foot of hood
Backshelf/pass-over	300
Double island canopy (per side)	300
Eyebrow	250
Single island canopy	500
Wall-mounted canopy	300

For SI: 1 cfm per linear foot = 1.55 L/s per linear meter.

507.5.4 Light-duty cooking appliances. The minimum net airflow for hoods, as determined by Section 507.1, used for *light-duty cooking appliances* and food service preparation shall be determined as follows:

Type of Hood	CFM per linear foot of hood
Backshelf/pass-over	250
Double island canopy (per side)	250
Eyebrow	250
Single island canopy	400
Wall-mounted canopy	200

For SI: 1 cfm per linear foot = 1.55 L/s per linear meter.

507.5.5 Dishwashing appliances. The minimum net airflow for Type II hoods used for dishwashing *appliances* shall be 100 cfm per linear foot (155 L/s per linear meter) of hood length.

Exception: Dishwashing *appliances* and *equipment* installed in accordance with Section 507.3.

507.6 Performance test. A performance test shall be conducted upon completion and before final approval of the installation of a ventilation system serving *commercial cooking appliances*. The test shall verify the rate of exhaust airflow required by

EXHAUST SYSTEMS

Section 507.5, makeup airflow required by Section 508 and proper operation as specified in this chapter. The permit holder shall furnish the necessary test *equipment* and devices required to perform the tests.

507.6.1 Capture and containment test. The permit holder shall verify capture and containment performance of the exhaust system. This field test shall be conducted with all *appliances* under the hood at operating temperatures, with all sources of outdoor air providing *makeup air* for the hood operating and with all sources of recirculated air providing conditioning for the space in which the hood is located operating. Capture and containment shall be verified visually by observing smoke or steam produced by actual or simulated cooking, such as that provided by smoke generators.

SECTION 508 COMMERCIAL KITCHEN MAKEUP AIR

[S] **508.1 Makeup air.** *Makeup air* shall be supplied during the operation of commercial kitchen exhaust systems that are provided for *commercial cooking appliances*. ~~((The amount of *makeup air* supplied to the building from all sources shall be approximately equal to the amount of *exhaust air* for all exhaust systems for the building.))~~ A separate *makeup air* system for the kitchen shall be capable of providing not less than 90 percent of the air to be exhausted. The *makeup air* shall not reduce the effectiveness of the exhaust system. *Makeup air* shall be provided by gravity or mechanical means or both. Mechanical *makeup air* systems shall be automatically controlled to start and operate simultaneously with the exhaust system. Exterior windows and doors shall not be used to provide commercial kitchen *makeup air*. *Makeup air* intake opening locations shall comply with Section 401.4.

Note: Refer to Section C403.7.7 of the *Seattle Energy Code* in addition to the requirements of this section.

Exceptions:

1. Where the total airflow for the exhaust system is less than 400 cfm, *makeup air* is not required; or
2. In atriums, food courts, and similar areas, occupant *ventilation air* that would otherwise exfiltrate or be exhausted by other mechanical exhaust systems may be used to provide all *makeup air*, or a portion of *makeup air* when a direct path through permanent openings exists for occupant *ventilation air* to transfer to the kitchen hood area. That portion of air not supplied by occupant *ventilation air* shall be provided by a separate *makeup air* system. The combined air quantity provided by a separate *makeup air* system and occupant *ventilation air* shall provide 100 percent of the air to be exhausted.

508.1.1 Makeup air temperature. The temperature differential between *makeup air* and the air in the conditioned space shall not exceed 10°F (6°C) if the amount of *makeup air* supply exceeds 2,500 cfm (1180 L/s) per space except where the added heating and cooling loads of the *makeup air* do not exceed the capacity of the HVAC system.

508.1.2 Air balance. Design plans for a facility with a commercial kitchen ventilation system shall include a schedule or diagram indicating the design outdoor air balance. The design outdoor air balance shall indicate all exhaust and replacement air for the facility, plus the net exfiltration if applicable. The total replacement air airflow rate shall equal the total exhaust airflow rate plus the net exfiltration.

508.2 Compensating hoods. Manufacturers of compensating hoods shall provide a label indicating the minimum exhaust flow, the maximum makeup airflow or both that provides capture and containment of the exhaust effluent.

Exception: Compensating hoods with *makeup air* supplied only from the front face discharge and side face discharge openings shall not be required to be labeled with the maximum makeup airflow.

SECTION 509 FIRE SUPPRESSION SYSTEMS

509.1 Where required. *Cooking appliances* required by Section 507.2 to have a Type I hood shall be provided with an *approved* automatic fire suppression system complying with the *International Building Code* and the *International Fire Code*.

SECTION 510 HAZARDOUS EXHAUST SYSTEMS

510.1 General. This section shall govern the design and construction of duct systems for hazardous exhaust and shall determine where such systems are required. Hazardous exhaust systems are systems designed to capture and control hazardous emissions generated from product handling or processes, and convey those emissions to the outdoors. Hazardous emissions include flammable vapors, gases, fumes, mists or dusts, and volatile or airborne materials posing a health hazard, such as toxic or corrosive materials. For the purposes of this section, the health-hazard rating of materials shall be as specified in NFPA 704.

For the purposes of the provisions of Section 510, a laboratory shall be defined as a facility where the use of chemicals is related to testing, analysis, teaching, research or developmental activities. Chemicals are used or synthesized on a nonproduction basis, rather than in a manufacturing process.

[S] 510.2 Where required. A hazardous exhaust system shall be required wherever operations involving the handling or processing of hazardous materials, in the absence of such exhaust systems and under normal operating conditions, have the potential to create one of the following conditions:

1. A flammable vapor, gas, fume, mist or dust is present in concentrations exceeding 25 percent of the lower flammability limit of the substance for the expected room temperature.
2. A vapor, gas, fume, mist or dust with a health-hazard rating of 4 is present in any concentration.
3. A vapor, gas, fume, mist or dust with a health-hazard rating of 1, 2 or 3 is present in concentrations exceeding 1 percent of the median lethal concentration of the substance for acute inhalation toxicity.

~~((Exception: Laboratories, as defined in Section 510.1, except where the concentrations listed in Item 1 are exceeded or a vapor, gas, fume, mist or dust with a health-hazard rating of 1, 2, 3 or 4 is present in concentrations exceeding 1 percent of the median lethal concentration of the substance for acute inhalation toxicity.))~~

In lieu of complying with this section, research and educational laboratories are permitted to comply with rules adopted by the Director for laboratory exhaust systems for hazardous materials.

Note: See Director's Rule 30-2005 for provisions on ventilation systems in research and educational laboratories.

[F] 510.2.1 Lumber yards and woodworking facilities. *Equipment* or machinery located inside buildings at lumber yards and woodworking facilities that generates or emits combustible dust shall be provided with an *approved* dust-collection and exhaust system installed in accordance with this section and the *International Fire Code*. *Equipment* and systems that are used to collect, process or convey combustible dusts shall be provided with an *approved* explosion-control system.

[F] 510.2.2 Combustible fibers. *Equipment* or machinery within a building that generates or emits combustible fibers shall be provided with an *approved* dust-collecting and exhaust system. Such systems shall comply with this code and the *International Fire Code*.

[S] 510.2.3 Model shops and other intermittent use facilities. *Equipment* or machinery located inside buildings that emit dust but are used on an intermittent basis, such as in model shops, research and development facilities, hobby, and other non-production uses, shall be provided with a local, point of use dust collection system. The dust collector is permitted to be a portable type with high efficiency filters to allow *exhaust air* to be discharged back into the space. Such collectors are not required to be provided with an *approved* explosion-control system. Such systems shall be limited to an aggregate airflow of no more than 1,500 cfm per room.

510.3 Design and operation. The design and operation of the exhaust system shall be such that flammable contaminants are diluted in noncontaminated air to maintain concentrations in the exhaust flow below 25 percent of the contaminant's lower flammability limit.

510.4 Incompatible materials and common shafts. Incompatible materials, as defined in the *International Fire Code*, shall not be exhausted through the same hazardous exhaust system. Hazardous exhaust systems shall not share common shafts with other duct systems, except where such systems are hazardous exhaust systems originating in the same fire area.

Exception: The provisions of this section shall not apply to laboratory exhaust systems where all of the following conditions apply:

1. All of the hazardous exhaust ductwork and other laboratory exhaust within both the occupied space and the shafts are under negative pressure while in operation.
2. The hazardous exhaust ductwork manifolded together within the occupied space must originate within the same fire area.
3. Hazardous exhaust ductwork originating in different fire areas and manifolded together in a common shaft shall meet the provisions of Section 717.5.3, Exception 1, Item 1.1 of the *International Building Code*.
4. Each control branch has a flow-regulating device.
5. Perchloric acid hoods and connected exhaust shall be prohibited from manifolding.
6. Radioisotope hoods are equipped with filtration, carbon beds or both where required by the *registered design professional*.
7. Biological safety cabinets are filtered.
8. Each hazardous exhaust duct system shall be served by redundant exhaust fans that comply with either of the following:

EXHAUST SYSTEMS

- 8.1. The fans shall operate simultaneously in parallel and each fan shall be individually capable of providing the required exhaust rate.
- 8.2. Each of the redundant fans is controlled so as to operate when the other fan has failed or is shut down for servicing.

510.5 Design. Systems for removal of vapors, gases and smoke shall be designed by the constant velocity or equal friction methods. Systems conveying particulate matter shall be designed employing the constant velocity method.

510.5.1 Balancing. Systems conveying explosive or radioactive materials shall be prebalanced by duct sizing. Other systems shall be balanced by duct sizing with balancing devices, such as dampers. Dampers provided to balance airflow shall have securely fixed minimum-position blocking devices to prevent restricting the flow below the required volume or velocity.

510.5.2 Emission control. The design of the system shall be such that the emissions are confined to the area in which they are generated by air currents, hoods or enclosures and shall be exhausted by a duct system to a safe location or treated by removing contaminants.

510.5.3 Hoods required. Hoods or enclosures shall be used where contaminants originate in a limited area of a space. The design of the hood or enclosure shall be such that air currents created by the exhaust systems will capture the contaminants and transport them directly to the exhaust duct.

510.5.4 Contaminant capture and dilution. The velocity and circulation of air in work areas shall be such that contaminants are captured by an airstream at the area where the emissions are generated and conveyed into a product-conveying duct system. Contaminated air from work areas where hazardous contaminants are generated shall be diluted below the thresholds specified in Section 510.2 with air that does not contain other hazardous contaminants.

510.5.5 Makeup air. *Makeup air* from all sources shall be provided during operations at a rate approximately equal to the rate that air is exhausted by the hazardous exhaust system. *Makeup air* shall be provided by gravity or mechanical means or both. Mechanical *makeup air* systems shall be automatically controlled to start and operate simultaneously with the exhaust system. The *makeup air* shall not reduce the effectiveness of the exhaust system. *Makeup air* intakes shall be located in accordance with Section 401.4.

510.5.6 Clearances. The minimum *clearance* between hoods and combustible construction shall be the *clearance* required by the duct system.

510.5.7 Ducts. Hazardous exhaust duct systems shall extend directly to the exterior of the building and shall not extend into or through ducts and *plenums*.

510.6 Penetrations. Penetrations of structural elements by a hazardous exhaust system shall conform to Sections 510.6.1 through 510.6.4.

Exception: Duct penetrations within Group H-5 *occupancies* as allowed by the *International Building Code*.

510.6.1 Fire dampers and smoke dampers. Fire dampers and smoke dampers are prohibited in hazardous exhaust ducts.

510.6.1.1 Shaft penetrations. Hazardous exhaust ducts that penetrate fire-resistance-rated shafts shall comply with Section 714.4.1 or 714.4.1.2 of the *International Building Code*.

510.6.2 Floors. Hazardous exhaust systems that penetrate a floor/ceiling assembly shall be enclosed in a fire-resistance-rated shaft constructed in accordance with the *International Building Code*.

510.6.3 Wall assemblies. Hazardous exhaust duct systems that penetrate fire-resistance-rated wall assemblies shall be enclosed in fire-resistance-rated construction from the point of penetration to the outlet terminal, except where the interior of the duct is equipped with an approved automatic fire suppression system. Ducts shall be enclosed in accordance with the *International Building Code* requirements for shaft construction and such enclosure shall have a minimum fire-resistance rating of not less than the highest fire-resistance-rated wall assembly penetrated.

510.6.4 Fire walls. Ducts shall not penetrate a fire wall.

510.7 Suppression required.

[S] 510.7.1 Ducts. Ducts shall be protected with an *approved* automatic fire suppression system installed in accordance with the *International Building Code*.

Exceptions:

1. An approved automatic fire suppression system shall not be required in ducts conveying materials, fumes, mists and vapors that are nonflammable and noncombustible under all conditions and at any concentrations.
2. Automatic fire suppression systems shall not be required in metallic and noncombustible, non-metallic exhaust ducts in semiconductor fabrication facilities.

3. An *approved* automatic fire suppression system shall not be required in ducts where the largest cross-sectional diameter of the duct is less than 10 inches (254 mm).
4. For laboratories, as defined in Section 510.1, automatic fire protection systems shall not be required ~~((#))~~ for metallic ducts that serve laboratory hoods or exhaust systems.
5. An *approved* automatic fire suppression system is not required in metallic ducts serving fume hoods if all fume hoods served by the duct are equipped with an *approved* fire suppression system.

~~((510.7.1))~~ **510.7.2 Duct cleanout.** Ducts conveying combustible dust as part of a dust collection system shall be equipped with cleanouts that are provided with approved access, predesigned to be disassembled for cleaning, or engineered for automatic cleanouts. Where provided, cleanouts shall be located at the base of each vertical duct riser and at intervals not exceeding 20 feet (6096 mm) in horizontal sections of duct.

[S] 510.7.3 Fume hoods. *Approved* automatic fire suppression shall be installed in fume hoods within which operations are conducted involving hazardous materials that have the potential to create a flammable vapor, gas, fume, mist, or dust in concentrations exceeding 25 percent of the lower flammability limit of the substance or mixture for the expected room temperature in the absence of the fume hood and under normal operating conditions.

510.8 Duct construction. Ducts used to convey hazardous exhaust shall be constructed of materials *approved* for installation in such an exhaust system and shall comply with one of the following:

1. Ducts shall be constructed of *approved* G90 galvanized sheet steel, with a minimum nominal thickness as specified in Table 510.8.
2. Ducts used in systems exhausting nonflammable corrosive fumes or vapors shall be constructed of nonmetallic materials that exhibit a flame spread index of 25 or less and a smoke-developed index of 50 or less when tested in accordance with ASTM E84 or UL 723 and that are *listed* and *labeled* for the application.

Where the products being exhausted are detrimental to the duct material, the ducts shall be constructed of alternative materials that are compatible with the exhaust.

**TABLE 510.8
MINIMUM DUCT THICKNESS**

DIAMETER OF DUCT OR MAXIMUM SIDE DIMENSION	MINIMUM NOMINAL THICKNESS		
	Nonabrasive materials	Nonabrasive/abrasive materials	Abrasive materials
0–8 inches	0.028 inch (No. 24 gage)	0.034 inch (No. 22 gage)	0.040 inch (No. 20 gage)
9–18 inches	0.034 inch (No. 22 gage)	0.040 inch (No. 20 gage)	0.052 inch (No. 18 gage)
19–30 inches	0.040 inch (No. 20 gage)	0.052 inch (No. 18 gage)	0.064 inch (No. 16 gage)
Over 30 inches	0.052 inch (No. 18 gage)	0.064 inch (No. 16 gage)	0.079 inch (No. 14 gage)

For SI: 1 inch = 25.4 mm.

510.8.1 Duct joints. Ducts shall be made tight with lap joints having a minimum lap of 1 inch (25 mm). Joints used in ANSI/SMACNA Round Industrial Duct Construction Standards and ANSI/SMACNA Rectangular Industrial Duct Construction Standards are also acceptable.

510.8.2 Clearance to combustibles. Ducts shall have a *clearance* to combustibles in accordance with Table 510.8.2. Exhaust gases having temperatures in excess of 600°F (316°C) shall be exhausted to a *chimney* in accordance with Section 511.2.

**TABLE 510.8.2
CLEARANCE TO COMBUSTIBLES**

TYPE OF EXHAUST OR TEMPERATURE OF EXHAUST (°F)	CLEARANCE TO COMBUSTIBLES (inches)
Less than 100	1
100–600	12
Flammable vapors	6

For SI: 1 inch = 25.4 mm, °C = [(°F) – 32]/1.8.

510.8.3 Explosion relief. Systems exhausting potentially explosive mixtures shall be protected with an *approved* explosion relief system or by an *approved* explosion prevention system designed and installed in accordance with NFPA 69. An explosion relief system shall be designed to minimize the structural and mechanical damage resulting from an explosion or

deflagration within the exhaust system. An explosion prevention system shall be designed to prevent an explosion or deflagration from occurring.

510.9 Supports. Ducts shall be supported at intervals not exceeding 10 feet (3048 mm). Supports shall be constructed of noncombustible material.

SECTION 511 DUST, STOCK AND REFUSE CONVEYING SYSTEMS

511.1 Dust, stock and refuse conveying systems. Dust, stock and refuse conveying systems shall comply with the provisions of Section 510, Sections 511.1.1 through 511.2 and the *International Fire Code*.

[S] 511.1.1 Collectors and separators. Collectors and separators involving such systems as centrifugal separators, bag filter systems and similar devices, and associated supports shall be constructed of noncombustible materials and shall be located on the exterior of the building or structure. A collector or separator shall not be located nearer than 10 feet (3048 mm) to combustible construction or to an unprotected wall or floor opening, unless the collector is provided with a metal vent pipe that extends above the highest part of any roof with a distance of 30 feet (9144 mm).

Exceptions:

1. Collectors such as “Point of Use” collectors, close extraction weld fume collectors, spray finishing booths, stationary grinding tables, sanding booths, and integrated or machine-mounted collectors shall be permitted to be installed indoors provided that the installation is in accordance with the *International Fire Code* and NFPA 70.
2. Collectors in independent exhaust systems handling combustible dusts shall be permitted to be installed indoors provided that such collectors are installed in compliance with the *International Fire Code* and ~~((NFPA 70))~~ the *Seattle Electrical Code*.

511.1.2 Discharge pipe. Discharge piping shall conform to the requirements for ducts, including clearances required for high-heat *appliances*, as contained in this code. A delivery pipe from a cyclone collector shall not convey refuse directly into the firebox of a boiler, furnace, Dutch oven, refuse burner, incinerator or other *appliance*.

511.1.3 Conveying systems exhaust discharge. An exhaust system shall discharge to the outside of the building either directly by flue or indirectly through the bin or vault into which the system discharges except where the contaminants have been removed. Exhaust system discharge shall be permitted to be recirculated provided that the solid particulate has been removed at a minimum efficiency of 99.9 percent at 10 microns (10.01 mm), vapor concentrations are less than 25 percent of the LFL, and *approved equipment* is used to monitor the vapor concentration.

511.1.4 Spark protection. The outlet of an open-air exhaust terminal shall be protected with an *approved* metal or other noncombustible screen to prevent the entry of sparks.

511.1.5 Explosion control. Explosion control shall be provided in accordance with the requirements of the *International Fire Code* on all systems that convey combustible dust or combustible refuse or stock that produces combustible dusts in such a manner that the concentration and conditions could create a fire or explosion hazard. Determination of concentrations or conditions that are deemed to not create a fire or explosion hazard shall be based on a Dust Hazard Analysis prepared in accordance with Section 2203.2 of the *International Fire Code*.

511.1.5.1 Screens. Where a screen is installed in a safety relief vent, the screen shall be attached so as to permit ready release under the explosion pressure.

511.1.5.2 Hoods. The relief vent shall be provided with an *approved* noncombustible cowl or hood, or with a counter-balanced relief valve or cover arranged to prevent the escape of hazardous materials, gases or liquids.

511.2 Exhaust outlets. Outlets for exhaust that exceed 600°F (315°C) shall be designed as a *chimney* in accordance with Table 511.2.

**TABLE 511.2
CONSTRUCTION, CLEARANCE AND TERMINATION REQUIREMENTS FOR SINGLE-WALL METAL CHIMNEYS**

CHIMNEYS SERVING	MINIMUM THICKNESS		TERMINATION			CLEARANCE				
	Walls (inch)	Lining	Above roof opening (feet)	Above any part of building within (feet)			Combustible construction (inches)		Noncombustible construction	
				10	25	50	Interior inst.	Exterior inst.	Interior inst.	Exterior inst.
High-heat appliances (Over 2,000°F) ^a	0.127 (No. 10 MSG)	4-1/2" laid on 4-1/2" bed	20	—	—	20	See Note c			

CHIMNEYS SERVING	MINIMUM THICKNESS		TERMINATION				CLEARANCE			
	Walls (inch)	Lining	Above roof opening (feet)	Above any part of building within (feet)			Combustible construction (inches)		Noncombustible construction	
				10	25	50	Interior inst.	Exterior inst.	Interior inst.	Exterior inst.
Low-heat appliances (1,000°F normal operation)	0.127 (No. 10 MSG)	None	3	2	—	—	18	6	Up to 18" diameter, 2" Over 18" diameter, 4"	
Medium-heat appliances (2,000°F maximum) ^b	0.127 (No. 10 MSG)	Up to 18" dia.— 2-1/2" Over 18"—4-1/2" on 4-1/2" bed	10	—	10	—	36	24		

For SI: 1 inch = 25.4 mm, 1 foot = 304.8 mm, °C = [(°F) – 32]/1.8.

- a. Lining shall extend from bottom to top of outlet.
- b. Lining shall extend from 24 inches below connector to 24 feet above.
- c. Clearance shall be as specified by the design engineer and shall have sufficient clearance from buildings and structures to avoid overheating combustible materials (maximum 160°F).

SECTION 512 SUBSLAB SOIL EXHAUST SYSTEMS

512.1 General. Where a subslab soil exhaust system is provided, the duct shall conform to the requirements of this section.

[S] 512.2 Materials. Subslab soil exhaust system duct material shall be air duct material *listed* and *labeled* to the requirements of UL 181 for Class 0 air ducts, or any of the following piping materials that comply with the (~~International~~) *Uniform Plumbing Code* as building sanitary drainage and vent pipe: cast iron; galvanized steel; copper or copper-alloy pipe and tube of a weight not less than type DWV; and plastic piping.

512.3 Grade. Exhaust system ducts shall not be trapped and shall have a minimum slope of 1/8 unit vertical in 12 units horizontal (1-percent slope).

512.4 Termination. Subslab soil exhaust system ducts shall extend through the roof and terminate not less than 6 inches (152 mm) above the roof and not less than 10 feet (3048 mm) from any operable openings or air intake.

512.5 Identification. Subslab soil exhaust ducts shall be permanently identified within each floor level by means of a tag, stencil or other *approved* marking.

SECTION 513 SMOKE CONTROL SYSTEMS

[F] 513.1 Scope and purpose. This section applies to mechanical and passive smoke control systems that are required by the *International Building Code* or the *International Fire Code*. The purpose of this section is to establish minimum requirements for the design, installation and acceptance testing of smoke control systems that are intended to provide a tenable environment for the evacuation or relocation of occupants. These provisions are not intended for the preservation of contents, the timely restoration of operations, or for assistance in fire suppression or overhaul activities. Smoke control systems regulated by this section serve a different purpose than the smoke and heat removal provisions found in Section 910 of the *International Building Code* or the *International Fire Code*.

[F] 513.2 General design requirements. Buildings, structures, or parts thereof required by the *International Building Code* or the *International Fire Code* to have a smoke control system or systems shall have such systems designed in accordance with the applicable requirements of Section 909 of the *International Building Code* and the generally accepted and well-established principles of engineering relevant to the design. The *construction documents* shall include sufficient information and detail to describe adequately the elements of the design necessary for the proper implementation of the smoke control systems. These documents shall be accompanied with sufficient information and analysis to demonstrate compliance with these provisions.

[F] 513.3 Special inspection and test requirements. In addition to the ordinary inspection and test requirements that buildings, structures and parts thereof are required to undergo, smoke control systems subject to the provisions of Section 909 of the *International Building Code* shall undergo special inspections and tests sufficient to verify the proper commissioning of the smoke control design in its final installed condition. The design submission accompanying the *construction documents* shall clearly detail procedures and methods to be used and the items subject to such inspections and tests. Such commissioning shall be in accordance with generally accepted engineering practice and, where possible, based on published standards for the

EXHAUST SYSTEMS

particular testing involved. The special inspections and tests required by this section shall be conducted under the same terms as found in Section 1704 of the *International Building Code*.

Note: See Seattle Fire Department (SFD) Administrative Rule 9.02.19.

[F] 513.4 Analysis. A rational analysis supporting the types of smoke control systems to be employed, their methods of operation, the systems supporting them and the methods of construction to be utilized shall accompany the submitted *construction documents* and shall include, but not be limited to, the items indicated in Sections 513.4.1 through 513.4.7.

[F] 513.4.1 Stack effect. The system shall be designed such that the maximum probable normal or reverse stack effects will not adversely interfere with the system's capabilities. In determining the maximum probable stack effects, altitude, elevation, weather history and interior temperatures shall be used.

[F] 513.4.2 Temperature effect of fire. Buoyancy and expansion caused by the design fire in accordance with Section 513.9 shall be analyzed. The system shall be designed such that these effects do not adversely interfere with its capabilities.

[F] 513.4.3 Wind effect. The design shall consider the adverse effects of wind. Such consideration shall be consistent with the wind-loading provisions of the *International Building Code*.

[F] 513.4.4 HVAC systems. The design shall consider the effects of the heating, ventilating and air-conditioning (HVAC) systems on both smoke and fire transport. The analysis shall include all permutations of systems' status. The design shall consider the effects of fire on the HVAC systems.

[F] 513.4.5 Climate. The design shall consider the effects of low temperatures on systems, property and occupants. Air inlets and exhausts shall be located so as to prevent snow or ice blockage.

[F] 513.4.6 Duration of operation. All portions of active or engineered smoke control systems shall be capable of continued operation after detection of the fire event for a period of not less than either 20 minutes or 1.5 times the calculated egress time, whichever is greater.

[F] 513.4.7 Smoke control system interaction. The design shall consider the interaction effects of the operation of multiple smoke control systems for all design scenarios.

[S][F] 513.5 Smoke barrier construction. Smoke barriers required for ((~~passive~~)) engineered smoke control and a smoke control system using the pressurization method shall comply with Section 709 of the *International Building Code*. The maximum allowable leakage area shall be the aggregate area calculated using the following leakage area ratios:

1. Walls: $A/A_w = 0.00100$
2. Interior exit stairways and ramps and exit passageways: $A/A_w = 0.00035$
3. Enclosed exit access stairways and ramps and all other shafts: $A/A_w = 0.00150$
4. Floors and roofs: $A/A_F = 0.00050$

where:

A = Total leakage area, square feet (m^2).

A_F = Unit floor or roof area of barrier, square feet (m^2).

A_w = Unit wall area of barrier, square feet (m^2).

The leakage area ratios shown do not include openings created by gaps around doors and operable windows. The total leakage area of the smoke barrier shall be determined in accordance with Section 513.5.1 and tested in accordance with Section 513.5.2.

[F] 513.5.1 Total leakage area. Total leakage area of the barrier is the product of the smoke barrier gross area times the allowable leakage area ratio, plus the area of other openings such as gaps around doors and operable windows.

[F] 513.5.2 Testing of leakage area. Compliance with the maximum total leakage area shall be determined by achieving the minimum air pressure difference across the barrier with the system in the smoke control mode for mechanical smoke control systems utilizing the pressurization method. Compliance with the maximum total leakage area of passive smoke control systems shall be verified through methods such as door fan testing or other methods, as *approved* by the fire code official.

[F] 513.5.3 Opening protection. Openings in smoke barriers shall be protected by automatic-closing devices actuated by the required controls for the mechanical smoke control system. Door openings shall be protected by door assemblies complying with the requirements of the *International Building Code* for doors in smoke barriers.

Exceptions:

1. Passive smoke control systems with automatic-closing devices actuated by spot-type smoke detectors *listed* for releasing service installed in accordance with the *International Building Code*.

[S][F] 513.11 (~~(Standby)~~) **Emergency power.** The smoke control system shall be supplied with (~~(standby)~~) emergency power in accordance with Section 2702 of the *International Building Code*.

[F] 513.11.1 **Equipment room.** The (~~(standby)~~) emergency power source and its transfer switches shall be in a room separate from the normal power transformers and switch gear and ventilated directly to and from the exterior. The room shall be enclosed with not less than 1-hour fire-resistance-rated fire barriers constructed in accordance with Section 707 of the *International Building Code* or horizontal assemblies constructed in accordance with Section 711 of the *International Building Code*, or both.

[F] 513.11.2 **Power sources and power surges.** Elements of the smoke management system relying on volatile memories or the like shall be supplied with uninterruptible power sources of sufficient duration to span 15-minute primary power interruption. Elements of the smoke management system susceptible to power surges shall be suitably protected by conditioners, suppressors or other *approved* means.

[F] 513.11.3 **Wiring.** In addition to meeting requirements of the *Seattle Electrical Code*, all wiring regardless of voltage, shall have fire-resistance-rated protection of at least two hours or as required in rules promulgated by the *code official*.

Exception: Subject to the approval of the *code official*, fire-resistance-rating is not required for wiring located in a parking garage.

[F] 513.12 **Detection and control systems.** Fire detection systems providing control input or output signals to mechanical smoke control systems or elements thereof shall comply with the requirements of Section 907 of the *International Building Code*. Such systems shall be equipped with a control unit complying with UL 864 and listed as smoke control *equipment*.

[F] 513.12.1 **Verification.** Control systems for mechanical smoke control systems shall include provisions for verification. Verification shall include positive confirmation of actuation, testing, manual override and the presence of power downstream of all disconnects. A preprogrammed weekly test sequence shall report abnormal conditions audibly, visually and by printed report. The preprogrammed weekly test shall operate all devices, *equipment* and components used for smoke control.

Exception: Where verification of individual components tested through the preprogrammed weekly testing sequence will interfere with, and produce unwanted effects to, normal building operation, such individual components are permitted to be bypassed from the preprogrammed weekly testing, where *approved* by the building official and in accordance with both of the following:

1. Where the operation of components is bypassed from the preprogrammed weekly test, presence of power downstream of all disconnects shall be verified weekly by a listed control unit.
2. Testing of all components bypassed from the preprogrammed weekly test shall be in accordance with Section 909.20.6 of the *International Fire Code*.

[S][F] 513.12.2 **Wiring.** (~~(In addition to meeting the requirements of NFPA 70, all wiring, regardless of voltage, shall be fully enclosed within continuous raceways.)~~) See Section 513.11.

[F] 513.12.3 **Activation.** Smoke control systems shall be activated in accordance with the *International Building Code* or the *International Fire Code*.

[S][F] 513.12.4 **Automatic control.** Where complete automatic control is required or used, the automatic control sequences shall be initiated from an appropriately zoned automatic sprinkler system complying with Section 903.3.1.1 of the *International Fire Code*, from manual controls provided with *ready access* for the fire department, and any smoke detectors (~~(required by engineering analysis)~~) in the building.

[F] 513.13 **Control-air tubing.** Control-air tubing shall be of sufficient size to meet the required response times. Tubing shall be flushed clean and dry prior to final connections. Tubing shall be adequately supported and protected from damage. Tubing passing through concrete or masonry shall be sleeved and protected from abrasion and electrolytic action.

[F] 513.13.1 **Materials.** Control-air tubing shall be hard-drawn copper, Type L, ACR in accordance with ASTM B42, ASTM B43, ASTM B68, ASTM B88, ASTM B251 and ASTM B280. Fittings shall be wrought copper or copper alloy, solder type in accordance with ASME B16.18 or ASME B16.22. Changes in direction shall be made with appropriate tool bends. Copper-alloy compression-type fittings shall be used at final connection to devices; other joints shall be brazed using a BCuP5 brazing alloy with solidus above 1,100°F (593°C) and liquidus below 1,500°F (816°C). Brazing flux shall be used on copper-to-copper alloy joints only.

Exception: Nonmetallic tubing used within control panels and at the final connection to devices provided that all of the following conditions are met:

1. Tubing shall comply with the requirements of Section 602.2.1.3.
2. Tubing and connected device shall be completely enclosed within a galvanized or paint-grade steel enclosure having a minimum thickness of 0.0296 inch (0.7534 mm) (No. 22 gage). Entry to the enclosure shall be by

EXHAUST SYSTEMS

copper tubing with a protective grommet of Neoprene or Teflon or by suitable brass compression to male barbed adapter.

3. Tubing shall be identified by appropriately documented coding.
4. Tubing shall be neatly tied and supported within the enclosure. Tubing bridging cabinets and doors or movable devices shall be of sufficient length to avoid tension and excessive stress. Tubing shall be protected against abrasion. Tubing connected to devices on doors shall be fastened along hinges.

[F] 513.13.2 Isolation from other functions. Control tubing serving other than smoke control functions shall be isolated by automatic isolation valves or shall be an independent system.

[F] 513.13.3 Testing. Control-air tubing shall be tested at three times the operating pressure for not less than 30 minutes without any noticeable loss in gauge pressure prior to final connection to devices.

[F] 513.14 Marking and identification. The detection and control systems shall be clearly marked at all junctions, accesses and terminations.

[F] 513.15 Control diagrams. Identical control diagrams shall be provided and maintained as required by the *International Fire Code*.

[F] 513.16 Fire fighter's smoke control panel. A fire fighter's smoke control panel for fire department emergency response purposes only shall be provided in accordance with the *International Fire Code*.

[F] 513.17 System response time. Smoke control system activation shall comply with the *International Fire Code*.

[F] 513.18 Acceptance testing. Devices, *equipment*, components and sequences shall be tested in accordance with the *International Fire Code*.

[F] 513.19 System acceptance. Acceptance of the smoke control system shall be in accordance with the *International Fire Code*.

SECTION 514 ENERGY RECOVERY VENTILATION SYSTEMS

514.1 General. Energy recovery ventilation systems shall be installed in accordance with this section. Where required for purposes of energy conservation, energy recovery ventilation systems shall comply with the *International Energy Conservation Code*. Ducted heat recovery ventilators shall be *listed* and *labeled* in accordance with UL 1812. Nonducted heat recovery ventilators shall be *listed* and *labeled* in accordance with UL 1815.

514.2 Prohibited applications. Energy recovery ventilation systems shall not be used in the following systems:

1. Hazardous exhaust systems covered in Section 510.
2. Dust, stock and refuse systems that convey explosive or flammable vapors, fumes or dust.
3. Smoke control systems covered in Section 513.
4. Commercial kitchen exhaust systems serving Type I hoods.
5. Clothes dryer exhaust systems covered in Section 504.

Exception: The application of ERV *equipment* that recovers sensible heat only utilizing coil-type heat exchangers shall not be limited by this section.

514.3 Access. A means of access shall be provided to the heat exchanger and other components of the system as required for service, maintenance, repair or replacement.

514.4 Recirculated air. Air conveyed within energy recovery systems shall not be considered as recirculated air where the energy recovery ventilation system is constructed to limit cross-leakage between air streams to less than 10 percent of the total airflow design capacity.

[S] SECTION 515 WASTE OR LINEN CHUTE VENTING

[S] 515.1 Chute venting and roof termination. The full diameter of waste and linen chutes shall extend a minimum of 3 feet (0.92 m) above the building roof and be gravity vented per NFPA 82.

Exceptions:

1. Waste and linen chutes are permitted to be mechanically ventilated by an exhaust fan in lieu of gravity venting. The exhaust fan shall be located outside the building at the top of the chute.

2. Where the trash chute does not extend to the highest floor of the building below the roof, the trash chute shall be permitted to vent to a sidewall louver termination by gravity venting or mechanical venting. The horizontal extension of the trash chute shall have the same cross-sectional area as the chute and shall be enclosed in rated construction equal to the rating of the shaft enclosure. No operable openings shall be located within 10 feet of the sidewall louver termination.

CHAPTER 6

DUCT SYSTEMS

User note:

About this chapter: Chapter 6 addresses duct systems used in HVAC systems and some exhaust systems. Some exhaust system ducts are addressed in Chapter 5, such as kitchen exhaust ducts and clothes dryer exhaust ducts. This chapter addresses air plenums such as above-ceiling and below-floor plenums. Section 607 covers fire and smoke dampers, consistent with the requirements of the International Building Code®.

SECTION 601 GENERAL

601.1 Scope. Duct systems used for the movement of air in air-conditioning, heating, ventilating and exhaust systems shall conform to the provisions of this chapter except as otherwise specified in Chapters 5 and 7.

Exception: Ducts discharging combustible material directly into any *combustion* chamber shall conform to the requirements of NFPA 82.

[W][S][BE] 601.2 Air movement in egress elements. Corridors shall not serve as supply, return, exhaust, relief or *ventilation* air ducts.

Exceptions:

1. Use of a corridor as a source of *makeup air* for exhaust systems in rooms that open directly onto such corridors, including toilet rooms, bathrooms, dressing rooms, ((~~smoking lounges~~)) and janitor closets, shall be permitted, provided that each such corridor is directly supplied with ((~~outdoor~~)) air at a rate greater than the rate of *makeup air* taken from the corridor.
2. Where located within a *dwelling unit*, the use of corridors for conveying return air shall not be prohibited.
3. Where located within tenant spaces of 1,000 square feet (93 m²) or less in area, use of corridors for conveying return air is permitted.
4. Transfer air movement required to maintain pressurization difference within health care facilities in accordance with ASHRAE 170.
5. Where such air is part of an engineered smoke control system.
6. Air supplied to corridors serving residential occupancies shall not be considered as providing ventilation air to the dwelling units and sleeping units subject to the following:
 - 6.1. The air supplied to the corridor is 100 percent outside air; and
 - 6.2. The dwelling units have conforming ventilation air independent of the air supplied to the corridor; and
 - 6.3. For other than high-rise buildings, the supply fan will automatically shut off upon activation of corridor smoke detectors installed in accordance with Section 606.2.4; or
 - 6.4. For high-rise buildings, the supply fan will automatically shut off upon activation of the smoke detectors required by Seattle Fire Code Section 907.2.12.1 or upon receipt of another approved fire alarm signal. The supply fan is not required to be automatically shut off when used as part of an approved building stairwell or elevator hoistway pressurization system. Corridor smoke detectors shall be installed in accordance with Section 606.2.5.

[BE] 601.2.1 Corridor ceiling. Use of the space between the corridor ceiling and the floor or roof structure above as a return air *plenum* is permitted for one or more of the following conditions:

1. The corridor is not required to be of fire-resistance-rated construction.
2. The corridor is separated from the *plenum* by fire-resistance-rated construction.
3. The air-handling system serving the corridor is shut down upon activation of the air-handling unit smoke detectors required by this code.
4. The air-handling system serving the corridor is shut down upon detection of sprinkler waterflow where the building is equipped throughout with an automatic sprinkler system.
5. The space between the corridor ceiling and the floor or roof structure above the corridor is used as a component of an *approved* engineered smoke control system.

SECTION 602 PLENUMS

[S] **602.1 General.** Supply, return, exhaust, relief and ventilation air *plenums* shall be limited to uninhabited crawl spaces, areas above a ceiling or below the floor, attic spaces, mechanical *equipment* rooms and the framing cavities addressed in Section 602.3. *Plenums* shall be limited to one fire area. Air systems that serve multiple fire areas shall be ducted from the boundary of the fire area served directly to the air-handling *equipment*. Fuel-fired *appliances* shall not be installed within a *plenum*.

[S] **602.2 Construction.** *Plenum* enclosure construction materials that are exposed to the airflow shall comply with the requirements of Section 703.5 of the *International Building Code* or such materials shall have a flame spread index of not more than 25 and a smoke-developed index of not more than 50 when tested in accordance with ASTM E84 or UL 723.

The use of gypsum boards to form *plenums* shall be limited to systems where the air temperatures do not exceed 125°F (52°C) and the building and mechanical system design conditions are such that the gypsum board surface temperature will be maintained above the airstream dew-point temperature as determined by the registered design professional. Supply air *plenums* formed by gypsum boards shall not be incorporated in air-handling systems utilizing *direct evaporative cooling* systems.

602.2.1 Materials within plenums. Except as required by Sections 602.2.1.1 through 602.2.1.8, materials within *plenums* shall be noncombustible or shall be *listed* and *labeled* as having a flame spread index of not more than 25 and a smoke-developed index of not more than 50 when tested in accordance with ASTM E84 or UL 723.

Exceptions:

1. Rigid and flexible ducts and connectors shall conform to Section 603.
2. Duct coverings, linings, tape and connectors shall conform to Sections 603 and 604.
3. This section shall not apply to materials exposed within *plenums* in one- and two-family dwellings.
4. This section shall not apply to smoke detectors.
5. Combustible materials fully enclosed within one of the following:
 - 5.1. Continuous noncombustible raceways or enclosures.
 - 5.2. Approved gypsum board assemblies.
 - 5.3. Materials *listed* and *labeled* for installation within a *plenum* and listed for the application.
6. Materials in Group H, Division 5 fabrication areas and the areas above and below the fabrication area that share a common air recirculation path with the fabrication area.

602.2.1.1 Wiring. Combustible electrical wires and cables and optical fiber cables exposed within a *plenum* shall be *listed* and *labeled* as having a peak optical density not greater than 0.50, an average optical density not greater than 0.15, and a flame spread distance not greater than 5 feet (1524 mm) when tested in accordance with NFPA 262, or shall be installed in metal raceways or metal sheathed cable. Combustible optical fiber and communication raceways exposed within a *plenum* shall be *listed* and *labeled* as having a peak optical density not greater than 0.5, an average optical density not greater than 0.15, and a flame spread distance not greater than 5 feet (1524 mm) when tested in accordance with UL 2024. Only plenum-rated wires and cables shall be installed in plenum-rated raceways.

602.2.1.2 Fire sprinkler piping. Plastic fire sprinkler piping exposed within a *plenum* shall be used only in wet pipe systems and shall be *listed* and *labeled* as having a peak optical density not greater than 0.50, an average optical density not greater than 0.15, and a flame spread distance not greater than 5 feet (1524 mm) when tested in accordance with UL 1887.

602.2.1.3 Pneumatic tubing. Combustible pneumatic tubing exposed within a *plenum* shall be *listed* and *labeled* as having a peak optical density not greater than 0.50, an average optical density not greater than 0.15, and a flame spread distance not greater than 5 feet (1524 mm) when tested in accordance with UL 1820.

602.2.1.4 Electrical equipment in plenums. Electrical *equipment* exposed within a *plenum* shall comply with Sections 602.2.1.4.1 and 602.2.1.4.2.

602.2.1.4.1 Equipment in metallic enclosures. Electrical *equipment* with metallic enclosures exposed within a *plenum* shall be permitted.

602.2.1.4.2 Equipment in combustible enclosures. Electrical *equipment* with combustible enclosures exposed within a *plenum* shall be *listed* and *labeled* for such use in accordance with UL 2043.

602.2.1.5 Discrete plumbing and mechanical products in plenums. Where discrete plumbing and mechanical products and appurtenances are located in a *plenum* and have exposed combustible material, they shall be *listed* and *labeled* for such use in accordance with UL 2043.

**SECTION 603
DUCT CONSTRUCTION AND INSTALLATION**

603.1 General. An air distribution system shall be designed and installed to supply the required distribution of air. The installation of an air distribution system shall not affect the fire protection requirements specified in the *International Building Code*. Ducts shall be constructed, braced, reinforced and installed to provide structural strength and durability.

603.2 Duct sizing. Ducts installed within a single *dwelling unit* shall be sized in accordance with ACCA Manual D, the *appliance* manufacturer’s installation instructions or other approved methods. Ducts installed within all other buildings shall be sized in accordance with the *ASHRAE Handbook of Fundamentals* or other equivalent computation procedure.

603.3 Duct classification. Ducts shall be classified based on the maximum operating pressure of the duct at pressures of positive or negative 0.5, 1.0, 2.0, 3.0, 4.0, 6.0 or 10.0 inches (1 inch w.c. = 248.7 Pa) of water column. The pressure classification of ducts shall equal or exceed the design pressure of the air distribution in which the ducts are utilized.

603.4 Metallic ducts. Metallic ducts shall be constructed as specified in the *SMACNA HVAC Duct Construction Standards—Metal and Flexible*.

Exception: Ducts installed within single *dwelling units* shall have a minimum thickness as specified in Table 603.4.

**TABLE 603.4
DUCT CONSTRUCTION MINIMUM SHEET METAL THICKNESS FOR SINGLE DWELLING UNITS^a**

ROUND DUCT DIAMETER (inches)	STATIC PRESSURE			
	1/2-inch water gauge		1-inch water gauge	
	Thickness (inches)		Thickness (inches)	
	Galvanized	Aluminum	Galvanized	Aluminum
< 12	0.013	0.018	0.013	0.018
12 to 14	0.013	0.018	0.016	0.023
15 to 17	0.016	0.023	0.019	0.027
18	0.016	0.023	0.024	0.034
19 to 20	0.019	0.027	0.024	0.034
RECTANGULAR DUCT DIMENSION (inches)	STATIC PRESSURE			
	1/2-inch water gauge		1-inch water gauge	
	Thickness (inches)		Thickness (inches)	
	Galvanized	Aluminum	Galvanized	Aluminum
≤ 8	0.013	0.018	0.013	0.018
9 to 10	0.013	0.018	0.016	0.023
11 to 12	0.016	0.023	0.019	0.027
13 to 16	0.019	0.027	0.019	0.027
17 to 18	0.019	0.027	0.024	0.034
19 to 20	0.024	0.034	0.024	0.034

For SI: 1 inch = 25.4 mm, 1-inch water gauge = 249 Pa.

a. Ductwork that exceeds 20 inches by dimension or exceeds a pressure of 1-inch water gauge shall be constructed in accordance with *SMACNA HVAC Duct Construction Standards—Metal and Flexible*.

603.4.1 Minimum fasteners. Round metallic ducts shall be mechanically fastened by means of not less than three sheet metal screws or rivets spaced equally around the joint.

Exception: Where a duct connection is made that is partially inaccessible, three screws or rivets shall be equally spaced on the exposed portion so as to prevent a hinge effect.

603.4.2 Duct lap. Crimp joints for round and oval metal ducts shall be lapped not less than 1 inch (25 mm) and the male end of the duct shall extend into the adjoining duct in the direction of airflow.

603.5 Nonmetallic ducts. Nonmetallic ducts shall be constructed with Class 0 or Class 1 duct material and shall comply with UL 181. Fibrous duct construction shall conform to the *SMACNA Fibrous Glass Duct Construction Standards* or *NAIMA Fibrous Glass Duct Construction Standards*. The air temperature within nonmetallic ducts shall not exceed 250°F (121°C).

[W][S] 603.5.1 Gypsum ducts. The use of gypsum boards to form air shafts (ducts) shall be limited to return air systems where the air temperatures do not exceed 125°F (52°C) and the gypsum board surface temperature is maintained above the airstream dew-point temperature as determined by the registered design professional. Supply air ducts formed by gypsum boards shall not be incorporated in air-handling systems utilizing *direct evaporative cooling* systems.

DUCT SYSTEMS

Exceptions:

1. Gypsum boards are permitted for ducts that are only used for stairway or elevator pressurization supply or relief air. The gypsum duct shall not attach directly to the equipment.
2. Gypsum boards coated on the inside with epoxy paint or foil-facing may be used for ventilation systems serving parking garages.
3. Gypsum boards coated on the inside with epoxy paint or foil-facing may be used for exhaust air ducts.

Note: Gypsum ducts shall be sealed in accordance with *Seattle Energy Code* Section C403.10.1.1.

603.5.2 Phenolic ducts. Nonmetallic phenolic ducts shall be constructed and installed in accordance with the SMACNA *Phenolic Duct Construction Standards*.

603.6 Flexible air ducts and flexible air connectors. Flexible air ducts, both metallic and nonmetallic, shall comply with Sections 603.6.1, 603.6.1.1, 603.6.3 and 603.6.4. Flexible air connectors, both metallic and nonmetallic, shall comply with Sections 603.6.2 through 603.6.4.

603.6.1 Flexible air ducts. Flexible air ducts, both metallic and nonmetallic, shall be tested in accordance with UL 181. Such ducts shall be *listed* and *labeled* as Class 0 or Class 1 flexible air ducts and shall be installed in accordance with Section 304.1.

603.6.1.1 Duct length. Flexible air ducts shall not be limited in length.

603.6.2 Flexible air connectors. Flexible air connectors, both metallic and nonmetallic, shall be tested in accordance with UL 181. Such connectors shall be *listed* and *labeled* as Class 0 or Class 1 flexible air connectors and shall be installed in accordance with Section 304.1.

603.6.2.1 Connector length. Flexible air connectors shall be limited in length to 14 feet (4267 mm).

603.6.2.2 Connector penetration limitations. Flexible air connectors shall not pass through any wall, floor or ceiling.

603.6.3 Air temperature. The design temperature of air to be conveyed in flexible air ducts and flexible air connectors shall be less than 250°F (121°C).

603.6.4 Flexible air duct and air connector clearance. Flexible air ducts and air connectors shall be installed with a minimum *clearance* to an *appliance* as specified in the *appliance* manufacturer's installation instructions.

603.7 Rigid duct penetrations. Duct system penetrations of walls, floors, ceilings and roofs and air transfer openings in such building components shall be protected as required by Section 607. Ducts in a private garage that penetrate a wall or ceiling that separates a dwelling from a private garage shall be continuous, shall be constructed of sheet steel having a thickness of not less than 0.0187 inch (0.4712 mm) (No. 26 gage) and shall not have openings into the garage. Fire and smoke dampers are not required in such ducts passing through the wall or ceiling separating a dwelling from a private garage except where required by Chapter 7 of the *International Building Code*.

603.8 Underground ducts. Ducts shall be *approved* for underground installation. Metallic ducts not having an *approved* protective coating shall be completely encased in not less than 2 inches (51 mm) of concrete.

603.8.1 Slope. Ducts shall have a minimum slope of 1/8 inch per foot (10.4 mm/m) to allow drainage to a point provided with access.

603.8.2 Sealing. Ducts shall be sealed, secured and tested prior to concrete encasement or direct burial. Ducts shall be leak tested as required by Section C403 of the *International Energy Conservation Code*.

603.8.3 Plastic ducts and fittings. Plastic ducts shall be constructed of PVC having a minimum pipe stiffness of 8 psi (55 kPa) at 5-percent deflection when tested in accordance with ASTM D2412. Plastic duct fittings shall be constructed of either PVC or high-density polyethylene. Plastic duct and fittings shall be utilized in underground installations only. The maximum design temperature for systems utilizing plastic duct and fittings shall be 150°F (66°C).

603.9 Joints, seams and connections. Longitudinal and transverse joints, seams and connections in metallic and nonmetallic ducts shall be constructed as specified in SMACNA *HVAC Duct Construction Standards—Metal and Flexible* and NAIMA *Fibrous Glass Duct Construction Standards*. Joints, longitudinal and transverse seams and connections in ductwork shall be securely fastened and sealed with welds, gaskets, mastics (adhesives), mastic-plus-embedded-fabric systems, liquid sealants or tapes. Tapes and mastics used to seal fibrous glass ductwork shall be *listed* and *labeled* in accordance with UL 181A and shall be marked "181 A-P" for pressure-sensitive tape, "181 A-M" for mastic or "181 A-H" for heat-sensitive tape. Tapes and mastics used to seal metallic and flexible air ducts and flexible air connectors shall comply with UL 181B and shall be marked "181 B-FX" for pressure-sensitive tape or "181 B-M" for mastic. Duct connections to flanges of air distribution system *equipment* shall be sealed and mechanically fastened. Mechanical fasteners for use with flexible nonmetallic air ducts shall comply with UL 181B and shall be marked "181 B-C." Closure systems used to seal all ductwork shall be installed in accordance with the manufacturer's instructions.

Exception: For ducts having a static pressure classification of less than 2 inches of water column (500 Pa), additional closure systems shall not be required for continuously welded joints and seams and locking-type joints and seams. This exception shall not apply to snap-lock and button-lock type joints and seams located outside of conditioned spaces.

603.10 Supports. Ducts shall be supported in accordance with SMACNA *HVAC Duct Construction Standards—Metal and Flexible*. Flexible and other factory-made ducts shall be supported in accordance with the manufacturer’s instructions.

[S] 603.10.1 Seismic loads. Bracing for ducts shall be designed to resist seismic loading, using accepted engineering practices and Chapter 16 of the *International Building Code*.

Interpretation: Duct bracing that complies with the SMACNA guideline “Seismic Restraint Manual Guidelines for Mechanical Systems” is deemed to comply with Section 603.10 and the *International Building Code*.

603.11 Furnace connections. Ducts connecting to a furnace shall have a *clearance* to combustibles in accordance with the furnace manufacturer’s installation instructions.

603.12 Condensation. Provisions shall be made to prevent the formation of condensation on the exterior of any duct.

[BS] 603.13 Flood hazard areas. For structures in flood hazard areas, ducts shall be located above the elevation required by Section 1612 of the *International Building Code* for utilities and attendant equipment or shall be designed and constructed to prevent water from entering or accumulating within the ducts during floods up to such elevation. If the ducts are located below the elevation required by Section 1612 of the *International Building Code* for utilities and attendant equipment, the ducts shall be capable of resisting hydrostatic and hydrodynamic loads and stresses, including the effects of buoyancy, during the occurrence of flooding up to such elevation.

[S] 603.14 Location. Ducts shall not be installed in or within 4 inches (102 mm) of the earth, except where such ducts comply with Section 603.8. Ducts installed in parking garages shall provide a clear floor height of not less than 6 feet 6 inches at the vehicle and pedestrian traffic areas, except where a minimum vertical clearance of 98 inches must be provided for required van-accessible parking spaces, access aisles serving them, and vehicular routes between the van-accessible parking spaces and the garage entrance and exit.

603.15 Mechanical protection. Ducts installed in locations where they are exposed to mechanical damage by vehicles or from other causes shall be protected by *approved* barriers.

603.16 Weather protection. Ducts including linings, coverings and vibration isolation connectors installed on the exterior of the building shall be protected against the elements.

603.17 Air dispersion systems. Air dispersion systems shall:

1. Be installed entirely in exposed locations.
2. Be utilized in systems under positive pressure.
3. Not pass through or penetrate fire-resistant-rated construction.
4. Be *listed* and *labeled* in compliance with UL 2518.

603.18 Registers, grilles and diffusers. Duct registers, grilles and diffusers shall be installed in accordance with the manufacturer’s instructions. Volume dampers or other means of supply air adjustment shall be provided in the branch ducts or at each individual duct register, grille or diffuser. Each volume damper or other means of supply air adjustment used in balancing shall be provided with access.

603.18.1 Floor registers. Floor registers shall resist, without structural failure, a 200-pound (90.8 kg) concentrated load on a 2-inch-diameter (51 mm) disc applied to the most critical area of the exposed face.

603.18.2 Prohibited locations. Diffusers, registers and grilles shall be prohibited in the floor or its upward extension within toilet and bathing rooms required by the *International Building Code* to have smooth, hard, non-absorbent surfaces.

Exception: *Dwelling units.*

SECTION 604 INSULATION

604.1 General. Duct insulation shall conform to the requirements of Sections 604.2 through 604.13 and the *International Energy Conservation Code*.

604.2 Surface temperature. Ducts that operate at temperatures exceeding 120°F (49°C) shall have sufficient thermal insulation to limit the exposed surface temperature to 120°F (49°C).

604.3 Coverings and linings. Duct coverings and linings, including adhesives where used, shall have a flame spread index not more than 25 and a smoke-developed index not more than 50, when tested in accordance with ASTM E84 or UL 723, using the specimen preparation and mounting procedures of ASTM E2231. Duct coverings and linings shall not flame, glow, smol-

SECTION 605 AIR FILTERS

[W] 605.1 General. ~~((Heating and air conditioning))~~ Air handlers and ventilation systems shall be provided with approved air filters in accordance with Section 605.4. Filters shall be installed such that all return air, recirculated air, outdoor air and makeup air is filtered upstream from any heat exchanger or coil. Filters shall be installed in an approved convenient location. Liquid adhesive coatings used on filters shall have a flash point not lower than 325°F (163°C).

Exceptions:

1. Cooling coils that are designed, controlled and operated to provide sensible cooling only do not require filtration at the terminal device.
2. Ambient air that enters the building through intentional openings for natural ventilation or by infiltration is not required to be filtered.
3. Recirculated air serving systems without wetted cooling coils or with unducted heater (hydronic coils, fossil fuel heating elements or electric resistance heating elements) do not require filtration at the terminal device.

605.2 Approval. Media-type and electrostatic-type air filters shall be *listed* and *labeled*. Media-type air filters shall comply with UL 900. High-efficiency particulate air filters shall comply with UL 586. Electrostatic-type air filters shall comply with UL 867. Air filters utilized within *dwelling units* shall be designed for the intended application and shall not be required to be *listed* and *labeled*.

605.3 Airflow over the filter. Ducts shall be constructed to allow an even distribution of air over the entire filter.

[W] 605.4 Particulate matter removal. Particulate matter filters or air cleaners shall have a minimum efficiency reporting value (MERV) of not less than the following:

1. MERV 13 for ducted air handlers and ventilation systems serving occupiable spaces in Groups A, B, E, M, R and I occupancies.
2. MERV 8 for ducted air handlers and ventilation systems serving occupiable spaces in Groups F, H, S, and U occupancies.
3. MERV 4 for unducted air handlers and fan coil units.

Exceptions:

1. Ducted air handlers and ventilation systems 500 cfm or less shall have a filter not less than MERV 8.
2. Recirculated air at fan powered variable air volume terminal units with hydronic heating coils or electric resistance heating elements shall have a filter not less than MERV 8.
3. Exhaust or relief air upstream of a heat exchanger or coil shall have a filter not less than MERV 6.

[S] 605.5 Smoke filtration. Air handlers and energy recovery ventilators serving occupiable spaces each with individual capacity greater than 500 cfm shall provide a filter box capable of housing a filter with a minimum efficiency reporting value (MERV) of not less than 13.

Exception: Air handlers that process 100 percent recirculated air with no outdoor air are not required to comply with this section.

SECTION 606 SMOKE DETECTION SYSTEMS CONTROL

606.1 Controls required. Air distribution systems shall be equipped with smoke detectors *listed* and *labeled* for installation in air distribution systems, as required by this section. Duct smoke detectors shall comply with UL 268A. Other smoke detectors shall comply with UL 268.

[S] 606.2 Where required. Smoke detectors shall be installed where indicated in Sections 606.2.1 through ~~((606.2.3))~~ 606.2.5.

Exception: Smoke detectors shall not be required where air distribution systems are incapable of spreading smoke beyond the enclosing walls, floors and ceilings of the room or space in which the smoke is generated.

[S] 606.2.1 Return air systems. Smoke detectors shall be installed in return air systems with a design capacity greater than 2,000 cfm (0.9 m³/s), in the return air duct or *plenum* upstream of any filters, *exhaust air* connections, outdoor air connections, or decontamination *equipment* and *appliances*.

Exceptions:

1. Smoke detectors are not required in the return air system where all portions of the building served by the air distribution system are protected by area smoke detectors connected to a fire alarm system in accordance with the *International Fire Code*. The area smoke detection system shall comply with Section 606.4.

DUCT SYSTEMS

2. Smoke detectors are not required in the air system where all of the air is exhausted and not recirculated back to any portion of the building. Additionally, smoke detectors are not required in the supply system that provide the makeup air for the exhaust system.

[S] 606.2.2 Common supply and return air systems. Where multiple air-handling systems share common supply or return air ducts or *plenums* with a combined design capacity greater than 2,000 cfm (0.9 m³/s), the return air system shall be provided with smoke detectors in accordance with Section 606.2.1.

Exception: Individual smoke detectors shall not be required for each fan-powered terminal unit, provided that such units do not have an individual design capacity greater than 2,000 cfm (0.9 m³/s) and will be shut down by activation of one of the following:

1. Smoke detectors required by Sections 601.2, 606.2.1 and 606.2.3.
2. An *approved* area smoke detector system located in the return air *plenum* serving such units.
3. An area smoke detector system as prescribed in the exception to Section 606.2.1.

~~(In all cases, the smoke detectors shall comply with Sections 606.4 and 606.4.1.)~~

The shutdown of fan-powered terminal units may be performed by a building automation system upon activation of smoke detection as described in Section 606.2.2, Exception Items 1, 2, or 3. The building automation system is not required to be listed as a smoke control system and is not required to comply with UL Standard 864: Standard for Control Units and Accessories for Fire Alarm Systems.

606.2.3 Return air risers. Where return air risers serve two or more stories and serve any portion of a return air system having a design capacity greater than 15,000 cfm (7.1 m³/s), smoke detectors shall be installed at each story. Such smoke detectors shall be located upstream of the connection between the return air riser and any air ducts or *plenums*.

[W] 606.2.4 Corridors serving Group R occupancies in other than high-rise buildings. Corridors that serve Group R occupancies in other than high-rise buildings and that are mechanically ventilated with supply air shall be equipped with smoke detectors spaced in accordance with NFPA 72. The supply fan shall automatically shut off upon activation of the corridor smoke detectors.

Exception: Corridor smoke detection is not required when air is returned back to the supply fan from the corridor and return air smoke detectors are installed in the return air duct or plenum upstream of any filters, exhaust air connections, outdoor air connections, or decontamination equipment and appliances designed to automatically shut off the supply fan.

[W] 606.2.5 Corridors serving Group R occupancies in high-rise buildings. Corridors that serve Group R occupancies in high-rise buildings and that are mechanically ventilated with supply air shall be equipped with smoke detectors that are spaced in accordance with NFPA 72 and air supply inlets to the corridor shall be provided with smoke/fire dampers. The supply inlet smoke/fire dampers shall automatically close upon activation of the corridor smoke detectors.

Exceptions:

1. Corridor smoke detection is not required to close the supply inlet smoke/fire dampers when the smoke/fire dampers are used as part of an approved building stairwell or elevator hoistway pressurization smoke control system.
2. Corridor smoke detection is not required when air is returned back to the supply fan from the corridor and return air smoke detectors are installed in the return air duct or plenum upstream of any filters, exhaust air connections, outdoor air connections, or decontamination equipment and appliances designed to automatically shut off the supply fan.

[F] 606.3 Installation. Smoke detectors required by this section shall be installed in accordance with NFPA 72. The required smoke detectors shall be installed to monitor the entire airflow conveyed by the system including return air and exhaust or relief air. Access shall be provided to smoke detectors for inspection and maintenance.

[F] 606.4 Controls operation. Upon activation, the smoke detectors shall shut down all operational capabilities of the air distribution system in accordance with the listing and labeling of *appliances* used in the system. Air distribution systems that are part of a smoke control system shall switch to the smoke control mode upon activation of a detector.

[S][F] 606.4.1 Supervision. The duct smoke detectors shall be connected to ~~((a fire alarm system))~~ the building's fire alarm control unit where a fire alarm system is required by Section 907.2 of the *International Fire Code*. Duct detectors shall not activate a fire alarm signal. The actuation of a duct smoke detector shall activate a visible and audible supervisory signal at a constantly attended location. In facilities that are required to be monitored by a supervising station, duct smoke detectors shall report only as a supervisory signal, not as a fire alarm.

Exceptions:

1. The supervisory signal at a constantly attended location is not required where the duct smoke detector activates the building's alarm-indicating *appliances*.

DUCT SYSTEMS

2. Class I or II leakage rating as specified in Section 607.3.2.2.

[BF] 607.3.3 Damper actuation. Damper actuation shall be in accordance with Sections 607.3.3.1 through 607.3.3.5 as applicable.

[BF] 607.3.3.1 Fire damper actuation. Primary heat-responsive devices used to actuate fire dampers shall meet one of the following requirements:

1. The operating temperature shall be approximately 50°F (28°C) above the normal temperature within the duct system, but not less than 160°F (71°C).
2. The operating temperature shall be not more than 350°F (177°C) where located in a smoke control system complying with Section 909 of the *International Building Code*.

Informative Note: Dampers associated with exhaust fans used for hoistway and stairway pressurization are permitted to comply with Section 607.3.3.1, item 2.

[BF] 607.3.3.2 Smoke damper actuation. The smoke damper shall close upon actuation of a *listed* smoke detector or detectors installed in accordance with Section 907.3 of the *International Building Code* and one of the following methods, as applicable:

1. Where a smoke damper is installed within a duct, a smoke detector shall be installed inside the duct or outside the duct with sampling tubes protruding into the duct. The detector or tubes within the duct shall be within 5 feet (1524 mm) of the damper. Air outlets and inlets shall not be located between the detector or tubes and the damper. The detector shall be *listed* for the air velocity, temperature and humidity anticipated at the point where it is installed. Other than in mechanical smoke control systems, dampers shall be closed upon fan shutdown where local smoke detectors require a minimum velocity to operate.
2. Where a smoke damper is installed above smoke barrier doors in a smoke barrier, a spot-type detector shall be installed on either side of the smoke barrier door opening. The detector shall be listed for releasing service if used for direct interface with the damper.
3. Where a smoke damper is installed within an unducted opening in a wall, a spot-type detector shall be installed within 5 feet (1524 mm) horizontally of the damper. The detector shall be listed for releasing service if used for direct interface with the damper.
4. Where a smoke damper is installed in a corridor wall or ceiling, the damper shall be permitted to be controlled by a smoke detection system installed in the corridor.
5. Where a smoke detection system is installed in all areas served by the duct in which the damper will be located, the smoke dampers shall be permitted to be controlled by the smoke detection system.

[BF] 607.3.3.3 Combination fire/smoke damper actuation. Combination fire/smoke damper actuation shall be in accordance with Sections 607.3.3.1 and 607.3.3.2. Combination fire/smoke dampers installed in smoke control system shaft penetrations shall not be activated by local area smoke detection unless it is secondary to the smoke management system controls.

[BF] 607.3.3.4 Ceiling radiation damper actuation. The operating temperature of a ceiling radiation damper actuation device shall be 50°F (28°C) above the normal temperature within the duct system, but not less than 160°F (71°C).

[BF] 607.3.3.5 Corridor damper actuation. Corridor damper actuation shall be in accordance with Sections 607.3.3.1 and 607.3.3.2.

[BF] 607.4 Access and identification. Access and identification of fire and smoke dampers shall comply with Sections 607.4.1 through 607.4.2.

[BF] 607.4.1 Access. Fire and smoke dampers shall be provided with an *approved* means of access that is large enough to permit inspection and maintenance of the damper and its operating parts. Dampers equipped with fusible links, internal operators or both shall be provided with an access door that is not less than 12 inches (305 mm) square or provided with a removable duct section.

[BF] 607.4.1.1 Fire-resistance rating. The access shall not affect the integrity of fire-resistance-rated assemblies. The access openings shall not reduce the fire-resistance rating of the assembly. Access doors in ducts shall be tight fitting and suitable for the required duct construction.

[BF] 607.4.1.2 Restricted access. Where space constraints or physical barriers restrict access to a damper for periodic inspection and testing, the damper shall be a single- or multi-blade damper and shall comply with the remote inspection requirements of NFPA 80 or NFPA 105.

[BF] 607.4.2 Identification. Access points shall be permanently identified on the exterior by a label having letters not less than 1/2 inch (12.7 mm) in height reading: FIRE/SMOKE DAMPER, SMOKE DAMPER or FIRE DAMPER.

[BF] 607.5 Where required. Fire dampers, smoke dampers, combination fire/smoke dampers, ceiling radiation dampers and corridor dampers shall be provided at the locations prescribed in Sections 607.5.1 through 607.5.7. Where an assembly is required to have both fire dampers and smoke dampers, combination fire/smoke dampers or a fire damper and smoke damper shall be provided.

[BF] 607.5.1 Fire walls. Ducts and air transfer openings permitted in fire walls in accordance with Section 706.11 of the *International Building Code* shall be protected with *listed* fire dampers installed in accordance with their listing.

[BF] 607.5.1.1 Horizontal exits. A *listed smoke damper* designed to resist the passage of smoke shall be provided at each point that a duct or air transfer opening penetrates a *fire wall* that serves as a horizontal *exit*.

[W][BF] 607.5.2 Fire barriers. Ducts and air transfer openings that penetrate fire barriers shall be protected with *listed* fire dampers installed in accordance with their listing. Ducts and air transfer openings shall not penetrate enclosures for interior exit stairways and ramps and exit passageways except as permitted by Sections 1023.5 and 1024.6, respectively, of the *International Building Code*.

Exception: Fire dampers are not required at penetrations of fire barriers where any of the following apply:

1. Penetrations are tested in accordance with ASTM E119 or UL 263 as part of the fire-resistance-rated assembly.
2. Ducts are used as part of an *approved* smoke control system in accordance with Section 513 and where the fire damper would interfere with the operation of the smoke control system.
3. Such walls are penetrated by fully ducted HVAC systems, have a required fire-resistance rating of 1 hour or less, are in areas of other than Group H and are in buildings equipped throughout with an automatic sprinkler system in accordance with Section 903.3.1.1 or 903.3.1.2 of the *International Building Code*. For the purposes of this exception, a fully ducted HVAC system shall be a duct system for the structure's HVAC system. Such a duct system shall be constructed of sheet steel not less than 26 gage [0.0217 inch (0.55 mm)] thickness and shall be continuous from the air-handling *appliance* or *equipment* to the air outlet and inlet terminals. Flexible air connectors shall be permitted in a fully ducted system, limited to the following installations:
 - 3.1. Nonmetallic flexible connections that connect a duct to an air handling unit or *equipment* located within a mechanical room or located outdoors in accordance with Section 603.9.
 - 3.2. Nonmetallic flexible air connectors in accordance with Section 603.6.2 that connect an overhead metal duct to a (~~ceiling~~) diffuser, grille or register where the metal duct and (~~ceiling~~) diffuser, grille or register are located within the same room.

[BF] 607.5.2.1 Horizontal exits. A *listed smoke damper* designed to resist the passage of smoke shall be provided at each point that a duct or air transfer opening penetrates a *fire barrier* that serves as a horizontal *exit*.

[W][BF] 607.5.3 Fire partitions. Ducts and air transfer openings that penetrate fire partitions shall be protected with *listed* fire dampers installed in accordance with their listing.

Exception: In *occupancies* other than Group H, fire dampers are not required where any of the following apply:

1. Corridor walls in buildings equipped throughout with an automatic sprinkler system in accordance with Section 903.3.1.1 or 903.3.1.2 of the *International Building Code* and the duct is protected as a through penetration in accordance with Section 714 of the *International Building Code*.
2. The partitions are tenant partitions in covered and open mall buildings where the walls are not required by provisions elsewhere in the *International Building Code* to extend to the underside of the floor or roof sheathing, slab or deck above.
3. The duct system is constructed of *approved* materials in accordance with Section 603 and the duct penetrating the wall complies with all of the following requirements:
 - 3.1. The duct shall not exceed 100 square inches (0.06 m²).
 - 3.2. The duct shall be constructed of steel not less than 0.0217 inch (0.55 mm) in thickness.
 - 3.3. The duct shall not have openings that communicate the corridor with adjacent spaces or rooms.
 - 3.4. The duct shall be installed above a ceiling.
 - 3.5. The duct shall not terminate at a wall register in the fire-resistance-rated wall.
 - 3.6. A minimum 12-inch-long (305 mm) by 0.060-inch-thick (1.52 mm) steel sleeve shall be centered in each duct opening. The sleeve shall be secured to both sides of the wall and all four sides of the sleeve with minimum 1-1/2-inch by 1-1/2-inch by 0.060-inch (38 mm by 38 mm by 1.52 mm) steel retaining angles. The retaining angles shall be secured to the sleeve and the wall with No. 10 (M5) screws. The annular space between the steel sleeve and the wall opening shall be filled with rock (mineral) wool batting on all sides.

DUCT SYSTEMS

- Such walls are penetrated by ducted HVAC systems, have a required fire-resistance rating of 1 hour or less, and are in areas of other than Group H and are in buildings equipped throughout with an automatic sprinkler system in accordance with Section 903.3.1.1 or 903.3.1.2 of the *International Building Code*. For the purposes of this exception, a ducted HVAC system shall be a duct system for conveying supply, return or *exhaust air* as part of the structure's HVAC system. Such a duct system shall be constructed of sheet steel not less than 26 gage in thickness and shall be continuous from the air-handling *appliance* or *equipment* to the air outlet and inlet terminals.

- 4.1. Nonmetallic flexible connections that connect a duct to an air-handling unit or equipment located within a mechanical room or located outdoors in accordance with Section 603.9.
- 4.2. Nonmetallic flexible air connectors in accordance with Section 603.6.2 that connect an overhead metal duct to a diffuser, grille, or register where the metal duct and diffuser, grille, or register are located in the same room. Where the fully ducted HVAC system metal ductwork penetrates a corridor fire partition, the ductwork shall be continuous without openings to the corridor, to a mechanical room, or to a shaft enclosure.

[BF] 607.5.4 Corridors/smoke barriers. A *listed* smoke damper designed to resist the passage of smoke shall be provided at each point a duct or air transfer opening penetrates a smoke barrier wall or a corridor enclosure required to have smoke and draft control doors in accordance with the *International Building Code*.

A corridor damper shall be provided where corridor ceilings, constructed as required for the corridor walls as permitted in Section 708.4, Exception 3, of the *International Building Code*, are penetrated.

A ceiling radiation damper shall be provided where the ceiling membrane of a fire-resistance-rated floor/ceiling or roof/ceiling assembly, constructed as permitted in Section 708.4, Exception 2, of the *International Building Code*, is penetrated.

Smoke dampers and smoke damper actuation methods shall comply with Section 607.5.4.1.

Exceptions:

- Smoke dampers are not required in corridor penetrations where the building is equipped throughout with an *approved* smoke control system in accordance with Section 513 and smoke dampers are not necessary for the operation and control of the system.
- Smoke dampers are not required in smoke barrier penetrations where the openings in ducts are limited to a single smoke compartment and the ducts are constructed of steel.
- Smoke dampers are not required in corridor penetrations where the duct is constructed of steel not less than 0.019 inch (0.48 mm) in thickness and there are no openings serving the corridor.
- Smoke dampers are not required in smoke barriers required by Section 407.5 of the *International Building Code* for Group I-2, Condition 2 where the HVAC system is fully ducted in accordance with Section 603 and where buildings are equipped throughout with an automatic sprinkler system in accordance with Section 903.3.1.1 of the *International Building Code* and equipped with quick-response sprinklers in accordance with Section 903.3.2 of the *International Building Code*.

[BF] 607.5.4.1 Smoke damper. Smoke dampers shall close as required by Section 607.3.3.2.

[S][BF] 607.5.5 Shaft enclosures. Shaft enclosures that are permitted to be penetrated by ducts and air transfer openings shall be protected with *listed* fire and smoke dampers installed in accordance with their listing.

Exceptions:

- Fire dampers are not required at penetrations of shafts where any of the following apply:
 - Steel exhaust subducts having a wall thickness of not less than 0.0187 inch (0.4712 mm) extend not less than 22 inches (559 mm) vertically in exhaust shafts and an exhaust fan is installed at the upper terminus of the shaft that is powered continuously, in accordance with Section 909.11 of the *International Building Code*, so as to maintain a continuous airflow upward to the outdoors.
 - Penetrations are tested in accordance with ASTM E119 or UL 263 as part of the fire-resistance-rated assembly.
 - Ducts are used as part of an *approved* smoke control system in accordance with Section 909 of the *International Building Code*, and where the fire damper will interfere with the operation of the smoke control system.
 - The penetrations are in parking garage exhaust or supply shafts that are separated from other building shafts by not less than 2-hour fire-resistance-rated construction.

2. In Group B and R *occupancies* equipped throughout with an automatic sprinkler system in accordance with Section 903.3.1.1 of the *International Building Code*, smoke dampers are not required at penetrations of shafts where kitchen, clothes dryer, bathroom, ~~((and))~~ toilet room, ~~accessory storage, and accessory trash room~~ exhaust openings with steel exhaust subducts, having a wall thickness of not less than 0.0187 inch (0.4712 mm), extend not less than 22 inches (559 mm) vertically and the exhaust fan at the upper terminus is ~~((powered continuously in accordance with the provisions of Section 909.11 of the International Building Code))~~ provided with a legally required standby power system in accordance with *Seattle Electrical Code* Section 701, and maintains airflow upward to the outdoors.
3. Smoke dampers are not required at penetrations of exhaust or supply shafts in parking garages that are separated from other building shafts by not less than 2-hour fire-resistance-rated construction.
4. Smoke dampers are not required at penetrations of shafts where ducts are used as part of an *approved* mechanical smoke control system designed in accordance with Section 909 of the *International Building Code* and where the smoke damper will interfere with the operation of the smoke control system.
5. Fire dampers and combination fire/smoke dampers are not required in kitchen and clothes dryer exhaust systems where dampers are prohibited by this code.

[BF] 607.5.5.1 Continuous upward flow. Fire dampers and smoke dampers shall not be installed in shafts that are required to maintain continuous airflow upward where closure of the damper would result in the loss of airflow.

[BF] 607.5.5.2 Enclosure at the bottom. Shaft enclosures that do not extend to the bottom of the building or structure shall be protected in accordance with Section 713.11 of the *International Building Code*.

[BF] 607.5.6 Exterior walls. Ducts and air transfer openings in fire-resistance-rated exterior walls required to have protected openings in accordance with Section 705.10 of the *International Building Code* shall be protected with *listed* fire dampers installed in accordance with their listing.

[BF] 607.5.7 Smoke partitions. A *listed* smoke damper designed to resist the passage of smoke shall be provided at each point where an air transfer opening penetrates a smoke partition. Smoke dampers and smoke damper actuation methods shall comply with Section 607.3.3.2.

Exception: Where the installation of a smoke damper will interfere with the operation of a required smoke control system in accordance with Section 513, *approved* alternative protection shall be used.

[BF] 607.6 Horizontal assemblies. Penetrations by air ducts of a floor, floor/ceiling assembly or the ceiling membrane of a roof/ceiling assembly shall be protected by a shaft enclosure that complies with Section 713 and Sections 717.6.1 through 717.6.3 of the *International Building Code* or shall comply with Sections 607.6.1 through 607.6.3.

[BF] 607.6.1 Through penetrations. In *occupancies* other than Groups I-2 and I-3, a duct constructed of *approved* materials in accordance with Section 603 that penetrates a fire-resistance-rated floor/ceiling assembly that connects not more than two stories is permitted without shaft enclosure protection provided that a *listed* fire damper is installed at the floor line or the duct is protected in accordance with Section 714.5 of the *International Building Code*. For air transfer openings, see Item 6, Section 712.1.9 of the *International Building Code*.

Exception: A duct is permitted to penetrate three floors or less without a fire damper at each floor provided that it meets all of the following requirements:

1. The duct shall be contained and located within the cavity of a wall and shall be constructed of steel having a minimum thickness of 0.0187 inch (0.4712 mm) (No. 26 gage).
2. The duct shall open into only one *dwelling unit* or *sleeping unit* and the duct system shall be continuous from the unit to the exterior of the building.
3. The duct shall not exceed a 4-inch (102 mm) nominal diameter and the total area of such ducts shall not exceed 100 square inches for any 100 square feet (64 516 mm² per 9.3 m²) of the floor area.
4. The annular space around the duct is protected with materials that prevent the passage of flame and hot gases sufficient to ignite cotton waste when subjected to ASTM E119 or UL 263 time-temperature conditions under a minimum positive pressure differential of 0.01 inch (2.49 Pa) of water at the location of the penetration for the time period equivalent to the fire-resistance rating of the construction penetrated.
5. Grille openings located in a ceiling of a fire-resistance-rated floor/ceiling or roof/ceiling assembly shall be protected with a *listed* ceiling radiation damper installed in accordance with Section 607.6.2.1.

[BF] 607.6.2 Membrane penetrations. Ducts and air transfer openings constructed of *approved* materials, in accordance with Section 603, that penetrate the ceiling membrane of a fire-resistance-rated floor/ceiling or roof/ceiling assembly shall be protected with one of the following:

1. A shaft enclosure in accordance with Section 713 of the *International Building Code*.

CHAPTER 7

COMBUSTION AIR

User note:

About this chapter: Chapter 7 defers to the International Fuel Gas Code® for combustion air provisions for gas-fired appliances. This code addresses oil-fired and solid-fuel-fired appliances; therefore, Chapter 7 is brief, referring to the manufacturer for solid-fuel appliances and NFPA 31 for oil-fired appliances. Combustion air must be provided to appliances to prevent poor combustion that can create multiple health and safety hazards.

SECTION 701 GENERAL

[S] 701.1 Scope. This chapter shall apply to oil-burning *appliances* and *equipment* to ensure that adequate air for safe *combustion* is provided. Solid fuel-burning *appliances*, *fireplaces* and *fireplace stoves* shall be provided with *combustion air* in accordance with the *appliance* manufacturer's installation instructions and *International Building Code* Section 2111. (~~Oil-fired appliances shall be provided with combustion air in accordance with NFPA 31. The methods of providing combustion air in this chapter do not apply to fireplaces, fireplace stoves and direct~~) *Direct-vent appliances* shall be provided with *combustion air* in accordance with the *appliance* manufacturer's installation instructions. The requirements for combustion and dilution air for gas-fired *appliances* shall be in accordance with the *International Fuel Gas Code*.

701.2 Dampened openings. Where combustion air openings are provided with volume, smoke or fire dampers, the dampers shall be interlocked with the firing cycle of the *appliances* served, so as to prevent operation of any *appliance* that draws combustion air from the room or space when any of the dampers are closed. Manual dampers shall not be installed in combustion air ducts. Ducts not provided with dampers and that pass through rated construction shall be enclosed in a shaft in accordance with the *International Building Code*.

[S] 701.3 Oil-burning appliance and equipment installation location. Oil-burning *appliances* and *equipment* shall be installed in locations where available ventilation permits satisfactory *combustion* of oil, proper venting of *combustion* gases, and maintenance of safe ambient temperatures under normal conditions of use. *Appliances* shall be located so that they do not interfere with the supply of air within the space.

Note: The provisions of Chapter 7 are based on NFPA 31-2016.

[S] 701.4 Tight construction. Where buildings are so tight that normal infiltration does not provide sufficient air for *combustion*, outside air shall be introduced.

[S] 701.5 Combustion air ducts. *Combustion* air ducts shall:

1. Be of galvanized steel complying with Chapter 6 or of equivalent corrosion-resistant material *approved* for this application.
Exception: Within *dwelling units*, unobstructed stud and joist spaces shall not be prohibited from conveying *combustion* air, provided that not more than one required fireblock is removed.
2. Have a minimum cross-sectional dimension of 3 inches (76 mm).
3. Terminate in an unobstructed space allowing free movement of *combustion* air to the *appliances*.
4. Have the same cross-sectional areas as the free area of the openings to which they connect.
5. Serve a single *appliance* enclosure.
6. Not serve both upper and lower *combustion* air openings where both such openings are used. The separation between ducts serving upper and lower *combustion* air openings shall be maintained to the source of *combustion* air.
7. Not be screened where terminating in an attic space.
8. Not slope downward toward the source of *combustion* air, where serving the upper required *combustion* air opening.

[S] 701.6 Prohibited sources. Openings and ducts shall not connect *appliance* enclosures with a space in which the operation of a fan will adversely affect the flow of the *combustion* air. *Combustion* air shall not be obtained from a hazardous location, except where the fuel-fired *appliances* are located within the hazardous location and are installed in accordance with this code. *Combustion* air shall not be taken from a refrigeration *machinery room*, except where a refrigerant vapor detector system is installed to automatically shut off the *combustion* process in the event of refrigerant leakage. *Combustion* air shall not be obtained from any location below the *design flood elevation*.

[S] 701.7 Opening location and protection. *Combustion* air openings to the outdoors shall comply with the location and protection provisions of Sections 401.4 and 401.5 applicable to outdoor air intake openings.

[S] SECTION 702 APPLIANCES LOCATED IN UNCONFINED SPACES

[S] 702.1 Unconfined spaces. In *unconfined spaces* air for *combustion* and ventilation shall be obtained directly from outdoors or from spaces that freely communicate with outdoors by means of a permanent opening or openings having a total free area of not less than 1 in.² per 5000 Btu/hr (28 in.² per gal/hr) (4.4 cm²/kW), based on the total input rating of all appliances in the space.

Exception: In buildings built prior to the 1986 edition of the *Washington State Energy Code with Seattle Amendments*, air for *combustion* shall be permitted to be supplied by normal infiltration.

[S] SECTION 703 APPLIANCES LOCATED IN CONFINED SPACES

[S] 703.1 Confined spaces. For appliances installed in confined spaces, air for *combustion* and ventilation shall be provided using one of the methods set forth in this section.

[S] 703.2 All air taken from inside the building. Where all *combustion* air will be taken from inside the building, the confined space shall be provided with two permanent openings as shown in Figure 703.2.1, one near the top of the space and one near the bottom.

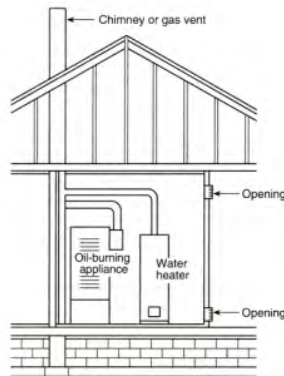

**FIGURE 703.2.1
APPLIANCES LOCATED IN CONFINED SPACES – ALL AIR TAKEN FROM INSIDE THE BUILDING**

[S] 703.2.1 Size of openings. Each opening shall have a free area of not less than 1 in.² per 1000 Btu/hr (140 in.² per gal/hr) (22 cm²/kW), based on the total input rating of all appliances in the space.

[S] 703.2.2 Source of air. Each opening shall freely communicate with interior areas of the building that, in turn, have adequate infiltration from the outside.

[S] 703.3 All air taken from outdoors. Where all air will be taken from outdoors, the confined space shall be provided with two permanent openings, one near the top of the space and one in or near the bottom.

[S] 703.3.1 Source of air. The openings shall communicate directly or by means of ducts with the outdoors or to spaces such as an attic or crawl space, that themselves freely communicate with the outdoors, as shown in Figure 703.3.2.1, Figure 703.3.2.2, and Figure 703.3.2.3.

[S] 703.3.2 Vertical ducts. Where communicating with the outdoors directly or by means of vertical ducts, each opening shall have a free area of not less than 1 inch² per 4000 Btu/hr (35 inch² per gal/hr) (5.5 cm²/kW), based on the total input rating of all appliances in the space.

[S] 703.3.3 Horizontal ducts. Where communicating with the outdoors by means of horizontal ducts, each opening shall have a free area of not less than 1 inch² per 2000 Btu/hr (70 inch² per gal/hr) (11 cm²/kW), based on the total input rating of all appliances in the space.

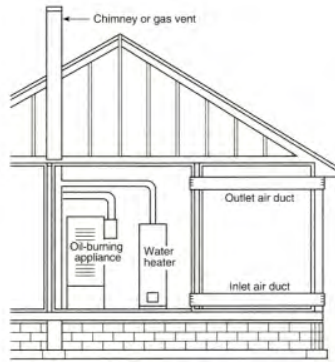

FIGURE 703.3.2.1
APPLIANCES LOCATED IN CONFINED SPACES –
ALL AIR FROM OUTDOORS

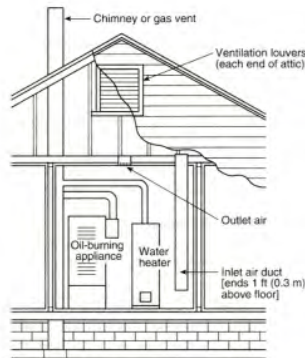
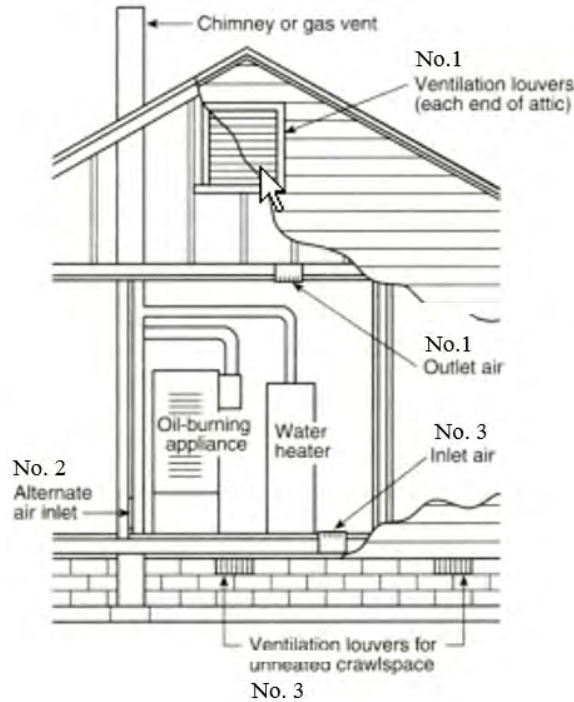

FIGURE 703.3.2.2
APPLIANCES LOCATED IN CONFINED SPACES –
ALL AIR FROM OUTDOORS THROUGH VENTILATED ATTIC

COMBUSTION AIR



Notes:

- Ducts used for make-up air can be connected to the cold air return of the heating system only if they connect directly to outdoor air.
- Nos. 1, 2, and 3 mark alternate locations for air from outdoors.
- Provide attic ventilation louvers at each end of attic with alternate air inlet No. 1.
- Provide crawl space ventilation louvers for unheated crawl space with alternate air inlet No. 3.

FIGURE 703.3.2.3
APPLIANCES LOCATED IN CONFINED SPACES, WITH VENTILATION AIR FROM INSIDE BUILDING AND COMBUSTION AIR FROM OUTSIDE, VENTILATED ATTIC, OR VENTILATED CRAWL SPACE

[S] 703.4 Ventilation air taken from inside the building—Combustion air taken from outdoors. Where *ventilation air* will be taken from inside the building and *combustion air* will be taken from outdoors, the confined space shall be provided with two openings for ventilation, located and sized as specified in Section 703.2 and as shown in Figure 703.3.2.3. In addition, there shall be one opening communicating directly with the outdoors or to spaces, such as an attic or crawl space, that freely communicates with the outdoors and has a free area of not less than 1 in.² per 5000 Btu/hr (28 in.² per gal/hr) (4.4 cm²/kW), based on the total input of all appliances in the space.

[S] SECTION 704 **COMBUSTION AIR FOR COMMERCIAL AND INDUSTRIAL INSTALLATIONS**

[S] 704.1 General. For commercial and industrial oil-burning *equipment*, permanent means for supplying an ample amount of outside air shall be provided in accordance with this section.

[S] 704.2 Size of openings. For furnace or boiler rooms adjacent to outside walls and where *combustion air* is provided by *natural ventilation* from the outside, there shall be a permanent air supply inlet having a total free area of not less than 1 in.² per 4000 Btu/hr (35 in.² per gal/hr) (5.5 cm²/kW), based on the total input rating of the burner or burners, but in no case less than 35 in.² (0.425 m²). For furnace or boiler rooms that are not adjacent to outside walls, the *combustion air* shall be supplied in a manner acceptable to the building official.

[S] SECTION 705 **LOUVERS AND GRILLES**

[S] 705.1 Louvers and grilles. In calculating the free area required by Sections 701, 702, 703 and 704, the blocking effect of louvers, grilles, or screens protecting openings shall be taken into consideration.

[S] 705.2 Screens. Screens used in louvers or grilles shall not be smaller than 1/4 in (6.3 mm) mesh and shall be accessible for cleaning.

[S] 705.3 Size of openings. If the free area through a particular design of louver or grille is known, it shall be used in calculating the size of the opening needed to provide the free area required. If the free area of the design is not known, it shall be assumed that wood louvers will have 20 percent to 25 percent free area and metal louvers and grilles will have 60 percent to 75 percent free area.

[S] SECTION 706
SPECIAL CONDITIONS

[S] 706.1 Special conditions. Where an appliance is installed in a location where the operation of exhaust fans, kitchen ventilation systems, clothes dryers or fireplaces can create conditions of unsatisfactory *combustion* or venting, special provisions shall be made subject to the approval of the building official.

CHIMNEYS AND VENTS

SECTION 804 DIRECT-VENT, INTEGRAL VENT AND MECHANICAL DRAFT SYSTEMS

804.1 Direct-vent terminations. Vent terminals for *direct-vent appliances* shall be installed in accordance with the manufacturer's instructions.

804.2 Appliances with integral vents. *Appliances* incorporating integral venting means shall be installed in accordance with their listings and the manufacturer's installation instructions.

804.2.1 Terminal clearances. *Appliances* designed for natural draft venting and incorporating integral venting means shall be located so that a minimum *clearance* of 9 inches (229 mm) is maintained between vent terminals and from any openings through which *combustion* products enter the building. *Appliances* using forced draft venting shall be located so that a minimum *clearance* of 12 inches (305 mm) is maintained between vent terminals and from any openings through which *combustion* products enter the building.

804.3 Mechanical draft systems. Mechanical draft systems of either forced or induced draft design shall be *listed* and *labeled* in accordance with UL 378 and shall comply with Sections 804.3.1 through 804.3.8.

804.3.1 Forced draft systems. Forced draft systems and all portions of induced draft systems under positive pressure during operation shall be designed and installed so as to be gas tight to prevent leakage of *combustion* products into a building.

804.3.2 Automatic shutoff. Power exhausters serving automatically fired *appliances* shall be electrically connected to each *appliance* to prevent operation of the *appliance* when the power exhauster is not in operation.

804.3.3 Termination. The termination of *chimneys* or vents equipped with power exhausters shall be located not less than 10 feet (3048 mm) from the lot line or from adjacent buildings. The exhaust shall be directed away from the building.

[S] **804.3.4 Horizontal terminations.** Horizontal terminations shall comply with the following requirements:

1. Where located adjacent to walkways, the termination of mechanical draft systems shall be not less than ~~((7))~~ 10 feet ~~((2134))~~ 3048 mm) above the level of the walkway.
2. Vents shall terminate not less than 3 feet (914 mm) above any forced air inlet located within 10 feet (3048 mm).
3. The vent system shall terminate not less than 4 feet (1219 mm) below, 4 feet (1219 mm) horizontally from or 1 foot (305 mm) above any door, window or gravity air inlet into the building.
4. The vent termination point shall not be located closer than 3 feet (914 mm) to an interior corner formed by two walls perpendicular to each other.
5. The vent termination shall not be mounted directly above or within 3 feet (914 mm) horizontally from an oil tank vent or gas meter.
6. The bottom of the vent termination shall be located not less than 12 inches (305 mm) above finished grade.

[S] **804.3.5 Vertical terminations.** Vertical terminations shall comply with the following requirements:

1. Where located adjacent to walkways, the termination of mechanical draft systems shall be not less than ~~((7))~~ 10 feet ~~((2134))~~ 3048 mm) above the level of the walkway.
2. Vents shall terminate not less than 3 feet (914 mm) above any forced air inlet located within 10 feet (3048 mm), ~~(horizontally.)~~
3. Where the vent termination is located below an adjacent roof structure, the termination point shall be located not less than 3 feet (914 mm) from such structure.
4. The vent shall terminate not less than 4 feet (1219 mm) below, 4 feet (1219 mm) horizontally from or 1 foot (305 mm) above any door, window or gravity air inlet for the building.
5. A vent cap shall be installed to prevent rain from entering the vent system.
6. The vent termination shall be located not less than 3 feet (914 mm) horizontally from any portion of the roof structure.

804.3.6 Exhauster connections. An *appliance* vented by natural draft shall not be connected into a vent, *chimney* or vent connector on the discharge side of a mechanical flue exhauster.

804.3.7 Exhauster sizing. Mechanical flue exhausters and the vent system served shall be sized and installed in accordance with the manufacturer's installation instructions.

804.3.8 Mechanical draft systems for manually fired appliances and fireplaces. A mechanical draft system shall be permitted to be used with manually fired *appliances* and fireplaces where such system complies with all of the following requirements:

1. The mechanical draft device shall be *listed* and *labeled* in accordance with UL 378, and shall be installed in accordance with the manufacturer's instructions.

SPECIFIC APPLIANCES, FIREPLACES AND SOLID FUEL-BURNING EQUIPMENT

labeled in accordance with the requirements of UL 1482 and shall be installed in accordance with the manufacturer's instructions. New wood-burning residential hydronic heaters shall be EPA certified.

905.2 Connection to fireplace. The connection of solid fuel *appliances* to *chimney* flues serving fireplaces shall comply with Sections 801.7 and 801.10.

905.3 Hearth extensions. Hearth extensions for fireplace stoves shall be installed in accordance with the listing of the fireplace stove. The hearth extension shall be readily distinguishable from the surrounding floor area. *Listed* and *labeled* hearth extensions shall comply with UL 1618.

SECTION 906 FACTORY-BUILT BARBECUE APPLIANCES

906.1 General. Factory-built barbecue *appliances* shall be of an *approved* type and shall be installed in accordance with the manufacturer's instructions, this chapter and Chapters 3, 5, 7 and 8, and the *International Fuel Gas Code*.

SECTION 907 INCINERATORS AND CREMATORIES

907.1 General. Incinerators and crematories shall be *listed* and *labeled* in accordance with UL 791 and shall be installed in accordance with the manufacturer's instructions.

SECTION 908 COOLING TOWERS, EVAPORATIVE CONDENSERS AND FLUID COOLERS

908.1 General. A cooling tower used in conjunction with an air-conditioning *appliance* shall be installed in accordance with the manufacturer's instructions. Factory-built cooling towers shall be *listed* in accordance with UL 1995 or UL/CSA 60335-2-40.

908.2 Access. Cooling towers, evaporative condensers and fluid coolers shall be provided with ready access.

908.3 Location. Cooling towers, evaporative condensers and fluid coolers shall be located to prevent the discharge of vapor plumes from entering occupied spaces. Plume discharges shall be not less than 5 feet (1524 mm) above or 20 feet (6096 mm) away from any ventilation inlet to a building. Location on the property shall be as required for buildings in accordance with the *International Building Code*.

908.4 Support and anchorage. Supports for cooling towers, evaporative condensers and fluid coolers shall be designed in accordance with the *International Building Code*. Seismic restraints shall be as required by the *International Building Code*.

[S] **908.5 Water supply.** Cooling towers, evaporative coolers and fluid coolers shall be provided with an approved water supply, sized for peak demand. The quality of water shall be provided in accordance with the *equipment* manufacturer's recommendations. The piping system and protection of the potable water supply system shall be installed as required by the (~~*International*~~) *Uniform Plumbing Code*.

908.6 Drainage. Drains, overflows and blowdown provisions shall be indirectly connected to an *approved* disposal location. Discharge of chemical waste shall be *approved* by the appropriate regulatory authority.

908.7 Refrigerants and hazardous fluids. Heat exchange *equipment* that contains a refrigerant and that is part of a closed refrigeration system shall comply with Chapter 11. Heat exchange *equipment* containing heat transfer fluids which are flammable, combustible or hazardous shall comply with the *International Fire Code*.

908.8 Cooling towers. Cooling towers, both open circuit and closed circuit type, and evaporative condensers shall comply with Sections 908.8.1 and 908.8.2.

908.8.1 Conductivity or flow-based control of cycles of concentration. Cooling towers and evaporative condensers shall include controls that automate system bleed based on conductivity, fraction of metered makeup volume, metered bleed volume, recirculating pump run time or bleed time.

908.8.2 Drift eliminators. Cooling towers and evaporative condensers shall be equipped with drift eliminators that have a maximum drift rate of 0.005 percent of the circulated water flow rate as established in the *equipment's* design specifications.

SPECIFIC APPLIANCES, FIREPLACES AND SOLID FUEL-BURNING EQUIPMENT

SECTION 913 CLOTHES DRYERS

913.1 General. Clothes dryers shall be installed in accordance with the manufacturer's instructions. Electric residential clothes dryers shall be tested in accordance with UL 2158. Electric coin-operated clothes dryers shall be tested in accordance with UL 2158. Electric commercial clothes dryers shall be tested in accordance with UL 1240.

913.2 Exhaust required. Clothes dryers shall be exhausted in accordance with Section 504.

913.3 Clearances. Clothes dryers shall be installed with *clearance* to combustibles in accordance with the manufacturer's instructions.

SECTION 914 SAUNA HEATERS

914.1 Location and protection. Sauna heaters shall be located so as to minimize the possibility of accidental contact by a person in the room.

914.1.1 Guards. Sauna heaters shall be protected from accidental contact by an *approved* guard or barrier of material having a low coefficient of thermal conductivity. The guard shall not substantially affect the transfer of heat from the heater to the room.

914.2 Installation. Sauna heaters shall be *listed* and *labeled* in accordance with UL 875 and shall be installed in accordance with their listing and the manufacturer's instructions.

914.3 Access. Panels, grilles and access doors that are required to be removed for normal servicing operations shall not be attached to the building.

914.4 Heat and time controls. Sauna heaters shall be equipped with a thermostat that will limit room temperature to 194°F (90°C). If the thermostat is not an integral part of the sauna heater, the heat-sensing element shall be located within 6 inches (152 mm) of the ceiling. If the heat-sensing element is a capillary tube and bulb, the assembly shall be attached to the wall or other support, and shall be protected against physical damage.

914.4.1 Timers. A timer, if provided to control main burner operation, shall have a maximum operating time of 1 hour. The control for the timer shall be located outside the sauna room.

914.5 Sauna room. A ventilation opening into the sauna room shall be provided. The opening shall be not less than 4 inches by 8 inches (102 mm by 203 mm) located near the top of the door into the sauna room.

914.5.1 Warning notice. The following permanent notice, constructed of *approved* material, shall be mechanically attached to the sauna room on the outside:

WARNING: DO NOT EXCEED 30 MINUTES IN SAUNA. EXCESSIVE EXPOSURE CAN BE HARMFUL TO HEALTH. ANY PERSON WITH POOR HEALTH SHOULD CONSULT A PHYSICIAN BEFORE USING SAUNA.

The words shall contrast with the background and the wording shall be in letters not less than 1/4-inch (6.4 mm) high.

Exception: This section shall not apply to one- and two-family dwellings.

SECTION 915 ENGINE AND GAS TURBINE-POWERED EQUIPMENT AND APPLIANCES

915.1 General. The installation of liquid-fueled stationary internal *combustion* engines and gas turbines, including exhaust, fuel storage and piping, shall meet the requirements of NFPA 37. Stationary engine generator assemblies shall meet the requirements of UL 2200.

915.2 Powered equipment and appliances. Permanently installed *equipment* and *appliances* powered by internal *combustion* engines and turbines shall be installed in accordance with the manufacturer's instructions and NFPA 37.

[W][S] 915.3 Installation of emergency and legally required power systems. Emergency power systems and legally required standby power systems required by the *International Building Code* or *International Fire Code* shall be installed in accordance with the *International Fire Code*, NFPA 70, NFPA 110, and NFPA 111.

Exceptions:

1. Where located within a sprinklered parking garage of Type I or II construction, emergency power and legally required standby power systems with fixed fuel quantities meeting the limits of Section 605.4 of the *International Fire Code*, and their transfer switches, are not required to be in a separate room. Other occupancies located in the story where the system is located shall be separated from the system by fire barriers with a minimum 1-hour fire resistance rating.

SPECIFIC APPLIANCES, FIREPLACES AND SOLID FUEL-BURNING EQUIPMENT

2. Combustion and radiator intake air are permitted to be transferred from the adjacent garage. Radiator discharge air is permitted to be transferred to the adjacent garage. Radiator ventilation intake and discharge air locations shall be separated to maintain the radiator ventilation intake air temperature below the maximum temperature allowed to meet the emergency and legally required standby power system loads.

915.3.1 Air intakes. Air intake opening locations for combustion and radiator cooling intake air shall be located on the exterior of the building in accordance with NFPA 110 and a minimum of 5 feet from the property line.

915.3.2 Air outlets. Air outlet opening locations shall comply with the following:

1. Combustion exhaust shall be located on the exterior of the building in accordance with Section 501.3.1 Item 2 for product conveying exhaust.
2. Radiator cooling outlet air shall be located on the exterior of the building in accordance with NFPA 110, a minimum of 5 feet from the property line and a minimum of 2 feet above grade.

915.4 Installation of optional standby power systems. Optional standby power systems shall be installed in accordance with the International Fire Code, NFPA 37, NFPA 70, and NFPA 111 as applicable.

915.4.1 Air intakes. Air intake opening locations for combustion and radiator cooling intake air shall be located on the exterior of the building in accordance with NFPA 110 and a minimum of 5 feet from the property line and may be located within an open or enclosed parking garage with sufficient exterior permanent opening area to provide the intake air.

915.4.2 Air outlets. Air outlet opening locations shall comply with the following:

1. Combustion exhaust shall be located on the exterior of the building in accordance with Section 501.3.1 Item 2 for product conveying exhaust.
2. Radiator cooling outlet air shall be located a minimum of 5 feet from the property line and may be discharged into an open or enclosed parking garage with sufficient exterior permanent opening area to relieve heat from the generator.

SECTION 916 POOL AND SPA HEATERS

916.1 General. Pool and spa heaters shall be installed in accordance with the manufacturer's instructions. Oil-fired pool and spa heaters shall be tested in accordance with UL 1261. Pool and spa heat pump water heaters shall comply with UL 1995, UL/CSA 60335-2-40 or CSA C22.2 No. 236.

Exception: Portable residential spas and portable residential exercise spas shall comply with UL 1563 or CSA C22.2 No. 218.1.

SECTION 917 COOKING APPLIANCES

917.1 Cooking appliances. *Cooking appliances* that are designed for permanent installation, including ranges, ovens, stoves, broilers, grills, fryers, griddles and barbecues, shall be *listed, labeled* and installed in accordance with the manufacturer's instructions. Commercial electric cooking *appliances* shall be *listed and labeled* in accordance with UL 197. Household electric ranges shall be *listed and labeled* in accordance with UL 858. Microwave cooking *appliances* shall be *listed and labeled* in accordance with UL 923. Oil-burning stoves shall be *listed and labeled* in accordance with UL 896. Solid-fuel-fired ovens shall be *listed and labeled* in accordance with UL 2162.

917.2 Domestic appliances. *Cooking appliances* installed within *dwelling units* and within areas where domestic cooking operations occur shall be *listed and labeled* as household-type *appliances* for domestic use.

[S] SECTION 918 (~~FORCED-AIR WARM-AIR FURNACES~~) AIR HANDLING UNITS

918.1 Forced-air furnaces. Oil-fired furnaces shall be tested in accordance with UL 727. Electric furnaces shall be tested in accordance with UL 1995 or UL/CSA 60335-2-40. Solid fuel furnaces shall be tested in accordance with UL 391. Forced-air furnaces shall be installed in accordance with the listings and the manufacturer's instructions.

918.2 Heat pumps. Electric heat pumps shall be tested in accordance with UL 1995 or UL/CSA 60335-2-40.

918.3 Dampers. Volume dampers shall not be placed in the air inlet to a furnace in a manner that will reduce the required air to the furnace.

SPECIFIC APPLIANCES, FIREPLACES AND SOLID FUEL-BURNING EQUIPMENT

SECTION 926 GASEOUS HYDROGEN SYSTEMS

926.1 Installation. The installation of gaseous hydrogen systems shall be in accordance with the applicable requirements of this code, the *International Fire Code*, the *International Fuel Gas Code* and the *International Building Code*.

SECTION 927 RADIANT HEATING SYSTEMS

927.1 General. Electric radiant heating systems shall be installed in accordance with the manufacturer's instructions and shall be *listed* for the application.

[S] **927.2 Clearances.** *Clearances* for radiant heating panels or elements to any wiring, outlet boxes and junction boxes used for installing electrical devices or mounting luminaires shall be in accordance with the *International Building Code* and ((NFPA-70)) *the Seattle Electrical Code*.

927.3 Installation on wood or steel framing. Radiant panels installed on wood or steel framing shall conform to the following requirements:

1. Heating panels shall be installed parallel to framing members and secured to the surface of framing members or shall be mounted between framing members.
2. Mechanical fasteners shall penetrate only the unheated portions provided for this purpose. Panels shall not be fastened at any point closer than 1/4 inch (6.4 mm) to an element. Other methods of attachment of the panels shall be in accordance with the panel installation instructions.
3. Unless *listed* and *labeled* for field cutting, heating panels shall be installed as complete units.

927.4 Installation in concrete or masonry. Radiant heating systems installed in concrete or masonry shall conform to the following requirements:

1. Radiant heating systems shall be identified as being suitable for the installation, and shall be secured in place as specified in the manufacturer's instructions.
2. Radiant heating panels and radiant heating panel sets shall not be installed where they bridge expansion joints unless they are protected from expansion and contraction.

927.5 Finish surfaces. Finish materials installed over radiant heating panels and systems shall be installed in accordance with the manufacturer's instructions. Surfaces shall be secured so that fasteners do not pierce the radiant heating elements.

SECTION 928 EVAPORATIVE COOLING EQUIPMENT

928.1 General. Evaporative cooling *equipment* shall:

1. Be installed in accordance with the manufacturer's instructions.
2. Be installed on level platforms in accordance with Section 304.10.
3. Have openings in exterior walls or roofs flashed in accordance with the *International Building Code*.
4. Be provided with an approved water supply, sized for peak demand. The quality of water shall be provided in accordance with the *equipment* manufacturer's recommendations. The piping system and protection of the potable water supply system shall be installed as required by the *International Plumbing Code*.
5. Have air intake opening locations in accordance with Section 401.4.

SECTION 929 UNVENTED ALCOHOL FUEL-BURNING DECORATIVE APPLIANCES

929.1 General. *Unvented alcohol fuel-burning decorative appliances* shall be *listed* and *labeled* in accordance with UL 1370 and shall be installed in accordance with the conditions of the listing, manufacturer's installation instructions and Chapter 3.

SECTION 930 LARGE-DIAMETER CEILING FANS

930.1 General. Where provided, large-diameter ceiling fans shall be tested and *labeled* in accordance with AMCA 230, *listed* and *labeled* in accordance with UL 507, and installed in accordance with the manufacturer's instructions.

CHAPTER 10

BOILERS, WATER HEATERS AND PRESSURE VESSELS

Note: Chapter 10 is not adopted in The City of Seattle.
Boilers, water heaters, and pressure vessels are regulated by the *Seattle Boiler and Pressure Vessel Code*.

CHAPTER 11

REFRIGERATION

User note:

***About this chapter:** Chapter 11 provides for the protection of life and property from the potential fire and health hazards associated with refrigerant chemicals and the machinery that contains such chemicals. Some refrigerants are toxic, some are flammable and some are both. This chapter refers to the International Fire Code®, ASHRAE 15 and IAR standards 2 through 5.*

SECTION 1101 GENERAL

1101.1 Scope. This chapter shall govern the design, installation, construction and repair of refrigeration systems that vaporize and liquefy a fluid during the refrigerating cycle. Permanently installed refrigerant storage systems and other components shall be considered as part of the refrigeration system to which they are attached.

[S] 1101.1.1 Refrigerants other than ammonia. Refrigerant piping design and installation for systems containing a refrigerant other than ammonia, including pressure vessels and pressure relief devices, shall comply with this chapter, ~~((and))~~ ASHRAE 15 and the Seattle Boiler and Pressure Vessel Code.

1101.1.2 Ammonia refrigerant. Refrigeration systems using ammonia as the refrigerant shall comply with IAR 2, IAR 3, IAR 4 and IAR 5 and shall not be required to comply with this chapter.

1101.2 Factory-built equipment and appliances. *Listed and labeled* self-contained, factory-built *equipment and appliances* shall be tested in accordance with the applicable standards specified in Table 1101.2. Such *equipment and appliances* are deemed to meet the design, manufacture and factory test requirements of this code if installed in accordance with their listing and the manufacturer’s instructions.

**TABLE 1101.2
FACTORY-BUILT EQUIPMENT AND APPLIANCES**

EQUIPMENT	STANDARDS
Refrigeration fittings, including press-connect, flared and threaded	UL 109 and UL 207
Air-conditioning equipment	UL 1995 or UL/CSA 60335-2-40
Packaged terminal air conditioners and heat pumps	UL 484 or UL/CSA 60335-2-40
Split-system air conditioners and heat pumps	UL 1995 or UL/CSA 60335-2-40
Dehumidifiers	UL 474 or UL/CSA 60335-2-40
Unit coolers	UL 412 or UL/CSA 60335-2-89
Commercial refrigerators, freezers, beverage coolers and walk-in coolers	UL 471 or UL/CSA 60335-2-89
Refrigerating units and walk-in coolers	UL 427 or UL 60335-2-89
Refrigerant-containing components and accessories	UL 207

1101.3 Protection. Any portion of a refrigeration system that is subject to physical damage shall be protected in an *approved* manner.

[S] 1101.4 Water connection. Water supply and discharge connections associated with refrigeration systems shall be made in accordance with this code and the ~~((International))~~ *Uniform Plumbing Code.*

1101.5 Fuel gas connection. Fuel gas devices, *equipment and appliances* used with refrigeration systems shall be installed in accordance with the *International Fuel Gas Code.*

1101.6 Maintenance. Mechanical refrigeration systems shall be maintained in proper operating condition, free from accumulations of oil, dirt, waste, excessive corrosion, other debris and leaks.

1101.7 Change in refrigerant type. The type of refrigerant in refrigeration systems having a refrigerant circuit containing more than 220 pounds (99.8 kg) of Group A1 or 30 pounds (13.6 kg) of any other group refrigerant shall not be changed without prior notification to the code official and compliance with the applicable code provisions for the new refrigerant type.

[F] 1101.8 Refrigerant discharge. Notification of refrigerant discharge shall be provided in accordance with the *International Fire Code.*

1101.9 Locking access port caps. Refrigerant circuit access ports located outdoors shall be fitted with locking-type tamper-resistant caps or shall be otherwise secured to prevent unauthorized access.

Exceptions:

1. *Machinery rooms* are not required for *listed equipment* and *appliances* containing not more than 6.6 pounds (3 kg) of refrigerant, regardless of the refrigerant’s safety classification, where installed in accordance with the *equipment’s* or *appliance’s* listing and the *equipment* or *appliance* manufacturer’s installation instructions.
2. Piping in compliance with Section 1107 is allowed in other locations to connect components installed in a *machinery room* with those installed outdoors.

1104.2.1 Institutional occupancies. The amounts shown in Table 1103.1 shall be reduced by 50 percent for all areas of institutional *occupancies* except kitchens, laboratories and mortuaries. The total of all Group A2, B2, A3 and B3 refrigerants shall not exceed 550 pounds (250 kg) in occupied areas or *machinery rooms*.

[S] 1104.2.2 Industrial occupancies and refrigerated rooms. This section applies only to rooms and spaces that: are within industrial *occupancies*; contain a refrigerant evaporator; are maintained at temperatures below 68°F (20°C); and are used for manufacturing, food and beverage preparation, meat cutting, other processes and storage. Where a *machinery room* would otherwise be required by Section 1104.2, a *machinery room* shall not be required where all of the following conditions are met:

1. The space containing the machinery is separated from other *occupancies* by tight construction with tight-fitting doors.
2. Access is restricted to authorized personnel.
3. Refrigerant detectors are installed as required for *machinery rooms* in accordance with Section 1105.3.

Exception: Refrigerant detectors are not required in unoccupied areas that contain only continuous piping that does not include valves, valve assemblies, *equipment* or *equipment* connections.

4. Surfaces having temperatures exceeding 800°F (427°C) and open flames are not present where any Group A2, B2, A3 or B3 refrigerant is used (see Section 1104.3.4).
5. All electrical *equipment* and *appliances* conform to Class I, Division 2, *hazardous location* classification requirements of ((NFPA 70)) the Seattle Electrical Code where the quantity of any Group A2, B2, A3 or B3 refrigerant in a single independent circuit would exceed 25 percent of the lower flammability limit (LFL) upon release to the space.
6. All refrigerant-containing parts in systems with a total connected compressor power exceeding 100 horsepower (hp) (74.6 kW)—except evaporators used for refrigeration or dehumidification, condensers used for heating, control and pressure relief valves for either, low-probability pumps and connecting piping—are located either outdoors or in a *machinery room*.



1104.3 Refrigerant restrictions. Refrigerant applications, maximum quantities and use shall be restricted in accordance with Sections 1104.3.1 through 1104.3.4.

1104.3.1 Air conditioning for human comfort. In other than industrial *occupancies* where the quantity in a single independent circuit does not exceed the amount in Table 1103.1, Group B1, B2 and B3 refrigerants shall not be used in high-probability systems for air conditioning for human comfort.

1104.3.2 Nonindustrial occupancies. Group A2 and B2 refrigerants shall not be used in high-probability systems where the quantity of refrigerant in any independent refrigerant circuit exceeds the amount shown in Table 1104.3.2. Group A3 and B3 refrigerants shall not be used except where *approved*.

Exception: This section does not apply to laboratories where the floor area per occupant is not less than 100 square feet (9.3 m²).

**TABLE 1104.3.2
MAXIMUM PERMISSIBLE QUANTITIES OF REFRIGERANTS**

TYPE OF REFRIGERATION SYSTEM	MAXIMUM POUNDS FOR VARIOUS OCCUPANCIES			
	Institutional	Public assembly	Residential	All other occupancies
Sealed absorption system				
In exit access	0	0	3.3	3.3
In adjacent outdoor locations	0	0	22	22
In other than exit access	0	6.6	6.6	6.6
Unit systems				
In other than exit access	0	0	6.6	6.6

For SI: 1 pound = 0.454 kg.

1104.3.3 All occupancies. The total of all Group A2, B2, A3 and B3 refrigerants shall not exceed 1,100 pounds (499 kg) except where *approved*.

REFRIGERATION

1104.3.4 Protection from refrigerant decomposition. Where any device having an open flame or surface temperature greater than 800°F (427°C) is used in a room containing more than 6.6 pounds (3 kg) of refrigerant in a single independent circuit, a hood and exhaust system shall be provided in accordance with Section 510. Such exhaust system shall exhaust *combustion* products to the outdoors.

Exception: A hood and exhaust system shall not be required where any of the following apply:

1. The refrigerant is R-718 (water) or R-744 (carbon dioxide).
2. The *combustion* air is ducted from the outdoors in a manner that prevents leaked refrigerant from being combusted.
3. A refrigerant detector is used to stop the *combustion* in the event of a refrigerant leak (see Sections 1105.3 and 1105.5).

1104.4 Volume calculations. Volume calculations shall be in accordance with Sections 1104.4.1 through 1104.4.3.

1104.4.1 Noncommunicating spaces. Where the refrigerant-containing parts of a system are located in one or more spaces that do not communicate through permanent openings or HVAC ducts, the volume of the smallest, enclosed occupied space shall be used to determine the permissible quantity of refrigerant in the system.

1104.4.2 Communicating spaces. Where an evaporator or condenser is located in an air duct system, the volume of the smallest, enclosed occupied space served by the duct system shall be used to determine the maximum allowable quantity of refrigerant in the system.

Exception: If airflow to any enclosed space cannot be reduced below one-quarter of its maximum, the entire space served by the air duct system shall be used to determine the maximum allowable quantity of refrigerant in the system.

[S] 1104.4.3 Plenums. Where the space above a suspended ceiling is continuous and part of the supply or return air *plenum* system, this space shall be included in calculating the volume of the enclosed space.

Interpretation: For variable refrigerant flow systems, the total allowable quantity of refrigerant in the system includes the refrigerant in the condensing unit, refrigerant controller, fan coil, and all associated piping.

SECTION 1105 MACHINERY ROOM, GENERAL REQUIREMENTS

[BF] 1105.1 Design and construction. *Machinery rooms* shall be designed and constructed in accordance with the *International Building Code* and this section.

1105.2 Openings. Ducts and air handlers in the *machinery room* that operate at a lower pressure than the room shall be sealed to prevent any refrigerant leakage from entering the airstream.

[S][F] 1105.3 Refrigerant ((~~detector~~)) detection system. ((Refrigerant detectors in *machinery rooms* shall be provided as required by Sections 608.9 and 608.18 of the *International Fire Code*.) Refrigeration *machinery rooms* shall contain a refrigerant detection system with an audible and visual alarm. The detector, or a sampling tube that draws air to the detector, shall be located in an area where refrigerant from a leak will concentrate. The alarm shall be actuated at a value not greater than the corresponding TLV-TWA values shown in this code for the refrigerant classification. Detectors and alarms shall be placed in approved locations. The detectors shall transmit a signal to an approved location.

1105.4 Tests. Periodic tests of the mechanical ventilating system shall be performed in accordance with manufacturer's specifications and as required by the code official.

1105.5 Fuel-burning appliances. Fuel-burning *appliances* and *equipment* having open flames and that use *combustion* air from the *machinery room* shall not be installed in a *machinery room*.

Exceptions:

1. Where the refrigerant is water (R-718) or carbon dioxide (R-744).
2. Fuel-burning *appliances* shall not be prohibited in the same *machinery room* with refrigerant-containing *equipment* or *appliances* where *combustion* air is ducted from outside the *machinery room* and sealed in such a manner as to prevent any refrigerant leakage from entering the *combustion* chamber, or where a refrigerant vapor detector is employed to automatically shut off the *combustion* process in the event of refrigerant leakage.

[S] 1105.6 Ventilation. *Machinery rooms* shall ((~~be mechanically ventilated~~)) have continuous mechanical ventilation to the outdoors.

Informative Note: The requirement for continuous mechanical ventilation to the outdoors means that fire dampers are not allowed on *machinery room* ventilation ducts.

Exception: Where a refrigerating system is located outdoors more than 20 feet (6096 mm) from any building opening and is enclosed by a penthouse, lean-to or other open structure, natural (~~(or mechanical)~~) ventilation shall be ~~((provided))~~ permitted. There shall be no openings to the building. Location of the openings shall be based on the relative density of the refrigerant to air. The free-aperture cross section for the ventilation of the *machinery room* shall be not less than:

$$F = \sqrt{G} \quad \text{(Equation 11-1)}$$

For SI: $F = 0.138\sqrt{G}$

where:

F = The free opening area in square feet (m²).

G = The mass of refrigerant in pounds (kg) in the largest system, any part of which is located in the *machinery room*.

1105.6.1 Discharge location. The discharge of the air shall be to the outdoors in accordance with Chapter 5. Exhaust from mechanical ventilation systems shall be discharged not less than 20 feet (6096 mm) from a property line or openings into buildings.

1105.6.1.1 Indoor exhaust opening location. Indoor mechanical exhaust intake openings shall be located where refrigerant leakage is likely to concentrate based on the refrigerant's relative density to air, and the locations of the air current paths and refrigerating machinery.

1105.6.2 Makeup air. Provisions shall be made for *makeup air* to replace that being exhausted. Openings for *makeup air* shall be located to avoid intake of *exhaust air*. Supply and exhaust ducts to the *machinery room* shall not serve any other area, shall be constructed in accordance with Chapter 5 and shall be covered with corrosion-resistant screen of not less than 1/4-inch (6.4 mm) mesh.

1105.6.3 Ventilation rate. Mechanical ventilation systems shall be capable of exhausting the minimum quantity of air both at normal operating and emergency conditions, as required by Sections 1105.6.3.1 and 1105.6.3.2. Multiple fans or multi-speed fans shall be allowed to produce the emergency ventilation rate and to obtain a reduced airflow for normal ventilation.

[S] 1105.6.3.1 Quantity—normal ventilation. During occupied conditions, the mechanical ventilation system shall exhaust the larger of the following:

1. Not less than 0.5 cfm per square foot (0.0025 m³/s • m²) of *machinery room* area, ~~((or 20 cfm (0.009 m³/s) per person.))~~
2. A volume required to limit the room temperature rise to 18°F (10°C) taking into account the ambient heating effect of all machinery in the room.
3. Not less than 20 cfm (0.009 m³/s) per person.

[S] 1105.6.3.1.1 Quantity—unoccupied condition. During unoccupied conditions, the mechanical ventilation system is permitted to exhaust the larger of the following:

1. Not less than 0.25 cfm per square foot (0.00125 m³/s • m²) of *machinery room* area; or
2. A volume required to limit the room temperature rise to 18°F (10°C) taking into account the ambient heating effect of all machinery in the room.

The system shall be provided with controls that increase the ventilation to the rate required for occupied spaces when the space is illuminated.

1105.6.3.2 Quantity—emergency conditions. Upon actuation of the refrigerant detector required in Section 1105.3, the mechanical ventilation system shall *exhaust air* from the *machinery room* in the following quantity:

$$Q = 100 \times \sqrt{G} \quad \text{(Equation 11-2)}$$

For SI: $Q = 0.07 \times \sqrt{G}$

where:

Q = The airflow in cubic feet per minute (m³/s).

G = The design mass of refrigerant in pounds (kg) in the largest system, any part of which is located in the *machinery room*.

[S][F] 1105.6.4 Standby source of power required. Where *mechanical ventilation*, treatment systems, temperature control, alarm, detection or other electrically operated systems are required, such systems shall be provided with a legally required standby source of power. See the *International Building Code* Chapter 27 and *Seattle Electrical Code* Article 701.

Exception: Legally required standby power is not required where an *approved* fail-safe engineered system is installed.

REFRIGERATION

[S] **1105.7 Termination of relief devices.** Pressure relief devices, fusible plugs and purge systems located within the *machinery room* shall terminate outside of the structure at a location not less than 15 feet (4572 mm) above the adjoining grade level and not less than 20 feet (6096 mm) from any window, ventilation opening or exit.

Note: For additional requirements regarding termination of relief devices for flammable refrigerants, toxic and highly toxic refrigerants, treatment systems, and flaring systems, see Section 606 of the *International Fire Code*.

[F] **1105.8 Emergency pressure control system.** Emergency pressure control systems shall be provided in accordance with Section 608.11 of the *International Fire Code*.

[BE] **1105.9 Means of egress.** *Machinery rooms* larger than 1,000 square feet (93 m²) shall have not less than two exits or exit access doorways. Where two exit access doorways are required, one such doorway is permitted to be served by a fixed ladder or an alternating tread device. Exit access doorways shall be separated by a horizontal distance equal to one-half the maximum horizontal dimension of the room. All portions of *machinery rooms* shall be within 150 feet (45 720 mm) of an exit or exit access doorway. An increase in exit access travel distance is permitted in accordance with Section 1017.1 of the *International Building Code*. Exit and exit access doorways shall swing in the direction of egress travel and shall be equipped with panic hardware, regardless of the occupant load served. Exit and exit access doorways shall be tight fitting and self-closing.

SECTION 1106 MACHINERY ROOM, SPECIAL REQUIREMENTS

1106.1 General. Where required by Section 1104.2, the *machinery room* shall meet the requirements of this section in addition to the requirements of Section 1105.

1106.2 Elevated temperature. There shall not be an open flame-producing device or continuously operating hot surface over 800°F (427°C) permanently installed in the room.

1106.3 Flammable refrigerants. Where refrigerants of Groups A2, A3, B2 and B3 are used, the *machinery room* shall conform to the Class I, Division 2, *hazardous location* classification requirements of NFPA 70.

Exception: *Machinery rooms* for systems containing Group A2L *refrigerants* that are provided with ventilation in accordance with Section 1106.4.

1106.4 Special requirements for Group A2L refrigerant machinery rooms. *Machinery rooms* with systems containing Group A2L *refrigerants* that do not conform to the Class I, Division 2, *hazardous location* electrical requirements of NFPA 70, as permitted by the exception to Section 1106.3, shall comply with Sections 1106.4.1 through 1106.4.3.

Exception: *Machinery rooms* conforming to the Class I, Division 2, *hazardous location* classification requirements of NFPA 70 are not required to comply with Sections 1106.4.1 and 1106.4.2.

[F] **1106.4.1 Ventilation system activation.** Ventilation shall be activated by the refrigerant detection system in the *machinery room*. Refrigerant detection systems shall be in accordance with Section 608.9 of the *International Fire Code* and all of the following:

1. The detectors shall activate at or below a refrigerant concentration of 25 percent of the LFL.
2. Upon activation, the detection system shall activate the emergency ventilation system required by Section 1106.4.2.
3. The detection, signaling and control circuits shall be supervised.

1106.4.2 Emergency ventilation system. An emergency ventilation system shall be provided at the minimum exhaust rate specified in ASHRAE 15 or Table 1106.4.2. Shutdown of the emergency ventilation system shall be by manual means.

**[W] TABLE 1106.4.2
MINIMUM EXHAUST RATES**

REFRIGERANT	Q(m/sec)	Q(cfm)
R32	15.4	32,600
R143A	13.6	28,700
R444A	6.46	13,700
R444B	10.6	22,400
R445A	7.83	16,600
R446A	23.9	50,700
R447A	23.8	50,400
R451A	7.04	15,000
R451B	7.05	15,000
R1234yf	7.80	16,600
R1234ze(E)	5.92	12,600

1106.4.3 Emergency ventilation system discharge. The emergency ventilation system point of discharge to the atmosphere shall be located outside of the structure at not less than 15 feet (4572 mm) above the adjoining grade level and not less than 20 feet (6096 mm) from any window, *ventilation* opening or *exit*.

[F] 1106.5 Remote controls. Remote control of the mechanical *equipment* and *appliances* located in the *machinery room* shall comply with Sections 1106.5.1 and 1106.5.2.

[F] 1106.5.1 Refrigeration system emergency shutoff. A clearly identified switch of the break-glass type or with an approved tamper-resistant cover shall provide off-only control of refrigerant compressors, refrigerant pumps, and normally closed, automatic refrigerant valves located in the *machinery room*. Additionally, this *equipment* shall be automatically shut off whenever the refrigerant vapor concentration in the *machinery room* exceeds the vapor detector's upper detection limit or 25 percent of the LEL, whichever is lower.

[F] 1106.5.2 Ventilation system. A clearly identified switch of the break-glass type or with an approved tamper-resistant cover shall provide on-only control of the *machinery room* ventilation fans.

[F] 1106.6 Emergency signs and labels. Refrigeration units and systems shall be provided with *approved* emergency signs, charts, and labels in accordance with the *International Fire Code*.

[S][F] 1106.7 Alarm activation. Where continuous ventilation is provided, failure of the ventilation system shall automatically activate an audible and visual alarm.

SECTION 1107 PIPING MATERIAL

1107.1 Piping. Refrigerant piping material for other than R-717 (ammonia) systems shall conform to the requirements in this section. Piping material and installations for R-717 (ammonia) refrigeration systems shall comply with IIAR 2.

1107.2 Used materials. Used pipe, fittings, valves and other materials that are to be reused shall be clean and free from foreign materials and shall be approved for reuse.

1107.3 Materials rating. Materials, joints and connections shall be rated for the operating temperature and pressure of the refrigerant system. Materials shall be suitable for the type of refrigerant and type of lubricant in the refrigerant system. Magnesium alloys shall not be used in contact with any halogenated refrigerants. Aluminum, zinc, magnesium and their alloys shall not be used in contact with R-40 (methyl chloride).

1107.4 Piping materials standards. Refrigerant pipe shall conform to one or more of the standards listed in Table 1107.4. The exterior of the pipe shall be protected from corrosion and degradation.

REFRIGERATION

**[S] TABLE 1107.4
REFRIGERANT PIPE**

PIPING MATERIAL	STANDARD
Aluminum tube	ASTM B210 ASTM B491/B491M
Brass (copper alloy) pipe	ASTM B43
Copper linesets	ASTM B280, ASTM B1003
Copper pipe	ASTM B42, ASTM B302
Copper tube ^a	ASTM B68, ASTM B75, ASTM B88, ASTM B280, ASTM B819
Steel pipe ^b	ASTM A53, ASTM A106
Steel tube	ASTM A254, ASTM A334

- a. Soft annealed copper tubing larger than 1-3/8 inch (35 mm) O.D. shall not be used for field-assembled refrigerant piping unless it is protected from mechanical damage.
- b. ASTM A53, ~~((Type F steel pipe shall not be used for))~~ refrigerant lines having an operating temperature less than -20°F (-29°C) shall be designed to meet the requirements of ASME B31.5, *Refrigeration Piping and Heat Transfer Components*.

1107.4.1 Steel pipe Groups A2, A3, B2 and B3. The minimum weight of steel pipe for Group A2, A3, B2 and B3 refrigerants shall be Schedule 80 for sizes 1-1/2 inches or less in diameter.

1107.5 Pipe fittings. Refrigerant pipe fittings shall be approved for installation with the piping materials to be installed, and shall conform to one of more of the standards listed in Table 1107.5 or shall be listed and labeled as complying with UL 207.

**TABLE 1107.5
REFRIGERANT PIPE FITTINGS**

FITTING MATERIAL	STANDARD
Aluminum	ASTM B361
Brass (copper alloy)	ASME B16.15, ASME B16.24
Copper	ASME B16.15, ASME B16.18, ASME B16.22, ASME B16.24, ASME B16.26, ASME B16.50
Steel	ASTM A105, ASTM A181, ASTM A193, ASTM A234, ASTM A420, ASTM A707

1107.5.1 Copper brazed field swaged. The minimum and maximum cup depth of field-fabricated copper brazed swaged fitting connections shall comply with Table 1107.5.1.

**TABLE 1107.5.1
COPPER BRAZED SWAGED CUP DEPTHS**

FITTING SIZE (inch)	MINIMUM DEPTH (inch)	MAXIMUM DEPTH (inch)
1/8	0.15	0.23
3/16	0.16	0.24
1/4	0.17	0.26
3/8	0.20	0.30
1/2	0.22	0.33
5/8	0.24	0.36
3/4	0.25	0.38
1	0.28	0.42
1-1/4	0.31	0.47
1-1/2	0.34	0.51
2	0.40	0.60
2-1/2	0.47	0.71
3	0.53	0.80
3-1/2	0.59	0.89
4	0.64	0.96

For SI: 1 inch = 25.4 mm.

1107.6 Valves. Valves shall be of materials that are compatible with the type of piping material, refrigerants and oils in the system. Valves shall be listed and labeled and rated for the temperatures and pressures of the refrigerant systems in which the valves are installed.

REFRIGERATION

1109.8.2 Refrigerating systems containing more than 100 pounds (45 kg) of refrigerant. In addition to stop valves required by Section 1109.8.1, systems containing more than 100 pounds (45 kg) of refrigerant shall have stop valves installed in the following locations:

1. Each inlet of each liquid receiver.
2. Each inlet and each outlet of each condenser where more than one condenser is used in parallel.

Exceptions:

1. Stop valves shall not be required at the inlet of a receiver in a condensing unit nor at the inlet of a receiver that is an integral part of the condenser.
2. Systems utilizing nonpositive displacement compressors.

1109.8.3 Stop valve support. Stop valves shall be supported to prevent detrimental stress and strain on the refrigerant piping system. The piping system shall not be utilized to support stop valves on copper tubing or aluminum tubing 1 inch (25.4 mm) outside diameter or larger.

1109.8.4 Identification. Stop valves shall be identified where their intended purpose is not obvious. Where valves are identified by a numbering or lettering system, legend(s) or key(s) for the valve identification shall be located in the room containing the indoor refrigeration *equipment*. The minimum height of lettering of the identification label shall be 1/2 inch (12.7 mm).

SECTION 1110 REFRIGERATION PIPING SYSTEM TEST

1110.1 General. Refrigerant piping systems, other than R-717 (ammonia) refrigeration systems, that are erected in the field shall be pressure tested for strength and leak tested for tightness, in accordance with the requirements of this section, after installation and before being placed in operation. Tests shall include both the high- and low-pressure sides of each system.

Exception: *Listed and labeled equipment*, including compressors, condensers, vessels, evaporators, gas bulk storage tanks, safety devices, pressure gauges and control mechanisms, shall not be required to be tested.

[S] **1110.2 Exposure of refrigerant piping system.** Refrigerant pipe and joints installed in the field shall be exposed for visual inspection and testing prior to being covered or enclosed.

Exception: Factory-insulated piping line sets are exempt from exposing piping material for visual inspection.

1110.3 Test gases. The medium used for pressure testing the refrigerant system shall be one of the following inert gases: oxygen-free nitrogen, helium or argon. For R-744 refrigerant systems, carbon dioxide shall be allowed as the test medium. For R-718 refrigerant systems, water shall be allowed as the test medium. Oxygen, air, combustible gases and mixtures containing such gases shall not be used as a test medium. Systems erected on the premises with tubing not exceeding 5/8 inch (15.9 mm) outside diameter shall be allowed to use the refrigerant identified on the nameplate label or marking as the test medium.

1110.4 Test apparatus. The means used to pressurize the refrigerant piping system shall have on its outlet side a test pressure measuring device and either a pressure-limiting device or a pressure-reducing device. The test pressure measuring device shall have an accuracy of ± 3 percent or less of the test pressure and shall have a resolution of 5 percent or less of the test pressure.

1110.5 Piping system pressure test and leak test. The refrigerant piping system shall be tested as a whole or separate tests shall be conducted for the low-pressure side and high-pressure side of the piping system. The refrigerant piping system shall be tested in accordance with both of the following methods:

1. The system shall be pressurized for a period of not less than 60 minutes to not less than the lower of the design pressures or the setting of the pressure relief device(s). The design pressures for testing shall be the pressure *listed* on the label nameplate of the condensing unit, compressor, compressor unit, pressure vessel or other system component with a nameplate. Additional test gas shall not be added to the system after the start of the pressure test. The system shall not show loss of pressure on the test pressure measuring device during the pressure test. Where using refrigerant as a test medium in accordance with Section 1110.3, the test pressure shall be not less than the saturation dew point pressure at 77°F (25°C).
2. A vacuum of 500 microns shall be achieved. After achieving a vacuum, the system shall be isolated from the vacuum pump. The system pressure shall not rise above 1,500 microns for a period of not less than 10 minutes.

1110.5.1 Joints and refrigerant-containing parts in air ducts. Joints and all refrigerant-containing parts of a refrigerating system located in an air duct of an air-conditioning system that conveys conditioned air to and from human-occupied spaces shall be tested at a pressure of 150 percent of the higher of the design pressure or pressure relief device setting.

1110.5.2 Limited charge systems. Limited charge systems with a pressure relief device, erected on the premises, shall be tested at a pressure not less than one and one-half times the pressure setting of the relief device. *Listed and labeled* limited charge systems shall be tested at the *equipment or appliance* design pressure.

CHAPTER 12

HYDRONIC PIPING

User note:

About this chapter: Chapter 12 addresses the piping systems used in heating and cooling systems. Such piping typically conveys water, water and antifreeze solutions, steam and condensate. The fluids conveyed are heated or cooled by boilers, chillers and heat pumps, which are all components of HVAC systems.

SECTION 1201 GENERAL

[S] 1201.1 Scope. The provisions of this chapter shall govern the construction, installation, *alteration* and repair of hydronic piping systems. This chapter shall apply to hydronic piping systems that are part of heating, ventilation and air-conditioning systems. Such piping systems shall include steam, hot water, chilled water, steam condensate and ground source heat pump loop systems. Potable cold and hot water distribution systems shall be installed in accordance with the ((*International*)) *Uniform Plumbing Code*.

1201.2 Sizing. Piping and piping system components for hydronic systems shall be sized for the demand of the system.

1201.3 Standards. As an alternative to the provisions of Sections 1202 and 1203, piping shall be designed, installed, inspected and tested in accordance with ASME B31.9.

SECTION 1202 MATERIAL

1202.1 Piping. Piping material shall conform to the standards cited in this section.

Exception: Embedded piping regulated by Section 1209.

1202.2 Used materials. Reused pipe, fittings, valves or other materials shall be clean and free from foreign materials and shall be *approved* by the code official for reuse.

1202.3 Material rating. Materials shall be rated for the operating temperature and pressure of the hydronic system. Materials shall be suitable for the type of fluid in the hydronic system.

1202.4 Piping materials standards. Hydronic pipe shall conform to the standards listed in Table 1202.4. The exterior of the pipe shall be protected from corrosion and degradation.

**TABLE 1202.4
HYDRONIC PIPE**

MATERIAL	STANDARD (see Chapter 15)
Acrylonitrile butadiene styrene (ABS) plastic pipe	ASTM D1527; ASTM F2806
Chlorinated polyvinyl chloride (CPVC) plastic pipe	ASTM D2846; ASTM F441; ASTM F442
Chlorinated polyvinyl chloride/aluminum/chlorinated polyvinyl chloride (CPVC/AL/CPVC)	ASTM F2855
Copper or copper-alloy pipe	ASTM B42; ASTM B43; ASTM B302
Copper or copper-alloy tube (Type K, L or M)	ASTM B75; ASTM B88; ASTM B135; ASTM B251
Cross-linked polyethylene/aluminum/cross-linked polyethylene (PEX-AL-PEX) pressure pipe	ASTM F1281; CSA CAN/CSA-B-137.10
Cross-linked polyethylene (PEX) tubing	ASTM F876; ASTM F3253; CSA B137.5
Ductile iron pipe	AWWA C115/A21.15; AWWA C151/A21.51
Lead pipe	FS WW-P-325B
Polyethylene/aluminum/polyethylene (PE-AL-PE) pressure pipe	ASTM F1282; CSA B137.9
Polypropylene (PP) plastic pipe	ASTM F2389
Polyvinyl chloride (PVC) plastic pipe	ASTM D1785; ASTM D2241
Raised temperature polyethylene (PE-RT)	ASTM F2623; ASTM F2769; CSA B137.18

SECTION 1205 VALVES

1205.1 Where required. Shutoff valves shall be installed in hydronic piping systems in the locations indicated in Sections 1205.1.1 through 1205.1.6.

1205.1.1 Heat exchangers. Shutoff valves shall be installed on the supply and return side of a heat exchanger.

Exception: Shutoff valves shall not be required where heat exchangers are integral with a boiler; or are a component of a manufacturer's boiler and heat exchanger packaged unit and are capable of being isolated from the hydronic system by the supply and return valves required by Section 1005.1.

1205.1.2 Central systems. Shutoff valves shall be installed on the building supply and return of a central utility system.

1205.1.3 Pressure vessels. Shutoff valves shall be installed on the connection to any pressure vessel.

1205.1.4 Pressure-reducing valves. Shutoff valves shall be installed on both sides of a pressure-reducing valve.

1205.1.5 Equipment and appliances. Shutoff valves shall be installed on connections to mechanical *equipment* and *appliances*. This requirement does not apply to components of a hydronic system such as pumps, air separators, metering devices and similar *equipment*.

1205.1.6 Expansion tanks. Shutoff valves shall be installed at connections to nondiaphragm-type expansion tanks.

1205.2 Reduced pressure. A pressure relief valve shall be installed on the low-pressure side of a hydronic piping system that has been reduced in pressure. The relief valve shall be set at the maximum pressure of the system design. The valve shall be installed in accordance with Section 1006.

SECTION 1206 PIPING INSTALLATION

1206.1 General. Piping, valves, fittings and connections shall be installed in accordance with the conditions of approval.

[S] **1206.2 System drain down.** Hydronic piping systems shall be designed and installed to permit the system to be drained. Where the system drains to the plumbing drainage system, the installation shall conform to the requirements of the (~~International~~) *Uniform Plumbing Code*.

Exception: The buried portions of systems embedded underground or under floors.

[S] **1206.3 Protection of potable water.** The potable water system shall be protected from backflow in accordance with the (~~International~~) *Uniform Plumbing Code*.

1206.4 Pipe penetrations. Openings for pipe penetrations in walls, floors or ceilings shall be larger than the penetrating pipe. Openings through concrete or masonry building elements shall be sleeved. The annular space surrounding pipe penetrations shall be protected in accordance with the *International Building Code*.

1206.5 Clearance to combustibles. A pipe in a hydronic piping system in which the exterior temperature exceeds 250°F (121°C) shall have a minimum *clearance* of 1 inch (25 mm) to combustible materials.

1206.6 Contact with building material. A hydronic piping system shall not be in direct contact with building materials that cause the piping material to degrade or corrode, or that interfere with the operation of the system.

1206.7 Water hammer. The flow velocity of the hydronic piping system shall be controlled to reduce the possibility of water hammer. Where a quick-closing valve creates water hammer, an *approved* water-hammer arrestor shall be installed. The arrestor shall be located within a range as specified by the manufacturer of the quick-closing valve.

1206.8 Steam piping pitch. Steam piping shall be installed to drain to the boiler or the steam trap. Steam systems shall not have drip pockets that reduce the capacity of the steam piping.

1206.9 Strains and stresses. Piping shall be installed so as to prevent detrimental strains and stresses in the pipe. Provisions shall be made to protect piping from damage resulting from expansion, contraction and structural settlement. Piping shall be installed so as to avoid structural stresses or strains within building components.

1206.9.1 Flood hazard. Piping located in a flood hazard area shall be capable of resisting hydrostatic and hydrodynamic loads and stresses, including the effects of buoyancy, during the occurrence of flooding to the *design flood elevation*.

1206.10 Pipe support. Pipe shall be supported in accordance with Section 305.

1206.11 Condensation. Provisions shall be made to prevent the formation of condensation on the exterior of piping.

HYDRONIC PIPING

SECTION 1207 TRANSFER FLUID

1207.1 Flash point. The flash point of transfer fluid in a hydronic piping system shall be not less than 50°F (28°C) above the maximum system operating temperature.

1207.2 Makeup water. The transfer fluid shall be compatible with the makeup water supplied to the system.

SECTION 1208 TESTS

1208.1 General. Hydronic piping systems shall be tested hydrostatically at one and one-half times the maximum system design pressure, but not less than 100 psi (689 kPa). The duration of each test shall be not less than 15 minutes.

Exception: For PEX piping systems, testing with a compressed gas shall be an alternative to hydrostatic testing where compressed air or other gas pressure testing is specifically authorized by all of the manufacturers' instructions for the PEX pipe and fitting products installed at the time the system is being tested, and compressed air or other gas testing is not otherwise prohibited by applicable codes, laws or regulations outside of this code.

SECTION 1209 EMBEDDED PIPING

1209.1 Materials. Piping for heating panels shall be standard-weight steel pipe, Type L copper tubing, polybutylene or other *approved* plastic pipe or tubing rated at 100 psi (689 kPa) at 180°F (82°C).

1209.2 Pressurizing during installation. Piping to be embedded in concrete shall be pressure tested prior to pouring concrete. During pouring, the pipe shall be maintained at the proposed operating pressure.

1209.3 Embedded joints. Joints of pipe or tubing that are embedded in a portion of the building, such as concrete or plaster, shall be in accordance with the requirements of Sections 1209.3.1 through 1209.3.5.

1209.3.1 Steel pipe joints. Steel pipe shall be welded by electrical arc or oxygen/acetylene method.

1209.3.2 Copper tubing joints. Copper tubing shall be joined by brazing complying with Section 1203.3.1.

1209.3.3 Polybutylene joints. Polybutylene pipe and tubing shall be installed in continuous lengths or shall be joined by heat fusion in accordance with Section 1203.9.1.

1209.3.4 Polyethylene of raised temperature (PE-RT) joints. PE-RT tubing shall be installed in continuous lengths or shall be joined by hydronic fittings listed in Table 1202.5.

1209.3.5 Cross-linked polyethylene (PEX) joints. PEX tubing shall be installed in continuous lengths or shall be joined by hydronic fittings listed in Table 1202.5.

1209.4 Not embedded related piping. Joints of other piping in cavities or running exposed shall be joined by *approved* methods in accordance with manufacturer's installation instructions and related sections of this code.

[W][S] 1209.5 Insulation and thermal break required. Radiant floor heating and snow melt systems shall be provided with insulation and a thermal break in accordance with Sections 1209.5.1 and 1209.5.2. Concrete slab-on-grade, asphalt and paver-system type pavements shall have a minimum of R-10 insulation installed under the area to be snow melted, or R-5 insulation shall be installed under and at the slab edges of the area to be snow melted. The insulation shall be located underneath the snow and ice melt hydronic piping or cable and along all edges of the pavement where the snow and ice melt system is installed in accordance with the snow and ice melt manufacturer's instructions. Insulation R-values for slab-on-grade and suspended floor installation shall be in accordance with the ~~((International Energy Conservation Code))~~ *Seattle Energy Code*.

~~((Exception: Insulation shall not be required in engineered systems where it can be demonstrated that the insulation will decrease the efficiency or have a negative effect on the installation.))~~

~~1209.5.1 ((Thermal break required)) Slab-on-grade insulation.~~ ~~((A thermal break shall be provided consisting of asphalt expansion joint materials or similar insulating materials at a point where a heated slab meets a foundation wall or other conductive slab.))~~ Radiant piping utilized in slab-on-grade applications shall be provided with insulating materials installed beneath the piping as required by the Washington State Energy Code.

1209.5.2 Insulation material marking. Insulating materials utilized in radiant floor heating systems shall be installed such that the manufacturer's R-value mark is readily observable upon inspection.

[S] **1210.7.6 Expansion tanks.** Shutoff valves shall be installed at connections to ((~~non-diaphragm-type~~)) expansion tanks. A method of draining the expansion tank downstream of the shutoff valve shall be provided.

1210.7.7 Reduced pressure. A pressure relief valve shall be installed on the low-pressure side of a hydronic piping system that has been reduced in pressure. The relief valve shall be set at the maximum pressure of the system design. The valve shall be installed in accordance with Section 1006.

1210.8 Installation. Piping, valves, fittings and connections shall be installed in accordance with ANSI/CSA/IGSHPA C448 and the manufacturer's instructions.

1210.8.1 Protection of potable water. Where ground-source heat pump ground-loop systems have a connection to a potable water supply, the potable water system shall be protected from backflow in accordance with the *International Plumbing Code*.

1210.8.2 Pipe penetrations. Openings for pipe penetrations in walls, floors and ceilings shall be larger than the penetrating pipe. Openings through concrete or masonry building elements shall be sleeved. The annular space surrounding pipe penetrations shall be protected in accordance with the *International Building Code*.

1210.8.3 Clearance from combustibles. A pipe in a ground-source heat pump piping system having an exterior surface temperature exceeding 250°F (121°C) shall have a minimum *clearance* of 1 inch (25 mm) from combustible materials.

1210.8.4 Contact with building material. A ground-source heat pump ground-loop piping system shall not be in direct contact with building materials that cause the piping or fitting material to degrade or corrode, or that interfere with the operation of the system.

1210.8.5 Strains and stresses. Piping shall be installed so as to prevent detrimental strains and stresses in the pipe. Provisions shall be made to protect piping from damage resulting from expansion, contraction and structural settlement. Piping shall be installed so as to avoid structural stresses or strains within building components.

1210.8.6 Flood hazard. Piping located in a flood hazard area shall be capable of resisting hydrostatic and hydrodynamic loads and stresses, including the effects of buoyancy, during the occurrence of flooding to the *design flood elevation*.

1210.8.7 Pipe support. Pipe shall be supported in accordance with Section 305.

1210.8.8 Velocities. Ground-source heat pump ground-loop systems shall be designed so that the flow velocities do not exceed the maximum flow velocity recommended by the pipe and fittings manufacturer and shall be controlled to reduce the possibility of water hammer.

1210.8.9 Labeling and marking. Ground-source heat pump ground-loop system piping shall be marked with tape, metal tags or other method where it enters a building indicating "GROUND-SOURCE HEAT PUMP LOOP SYSTEM." The marking shall indicate any antifreeze used in the system by name and concentration.

1210.8.10 Chemical compatibility. Antifreeze and other materials used in the system shall be chemically compatible with the pipe, tubing, fittings and mechanical systems.

1210.9 Makeup water. The transfer fluid shall be compatible with the makeup water supplied to the system.

1210.10 Tests. Before connection header trenches are backfilled, the assembled loop system shall be pressure tested with water at 100 psi (689 kPa) for 15 minutes, in which time there shall not be observed leaks. Flow and pressure loss testing shall be performed and the actual flow rates and pressure drops shall be compared to the calculated design values. If actual flow rate or pressure drop values differ from calculated design values by more than 10 percent, the cause shall be identified and corrective action taken.

1210.11 Embedded piping. Ground-source heat pump ground-loop piping to be embedded in concrete shall be pressure tested prior to pouring concrete. During pouring, the pipe shall be maintained at the proposed operating pressure.

CHAPTER 13

FUEL OIL PIPING AND STORAGE

User note:

***About this chapter:** Chapter 13 is devoted to fuel oil piping and fuel oil storage related to heating appliances, power generators and similar equipment/appliances. The requirements focus on preventing fuel leaks and equipment failures that could result in severe fire hazards.*

SECTION 1301 GENERAL

1301.1 Scope. This chapter shall govern the design, installation, construction and repair of fuel oil storage and piping systems. The storage of fuel oil and flammable and combustible liquids shall be in accordance with Chapters 6 and 57 of the *International Fire Code*.

[S] **1301.2 Storage and piping systems.** Fuel oil storage systems shall comply with Section ~~((603.3))~~ 605.4 of the *International Fire Code*. Fuel oil piping systems shall comply with the requirements of this code.

1301.3 Fuel type. An *appliance* shall be designed for use with the type of fuel to which it will be connected. Such *appliance* shall not be converted from the fuel specified on the rating plate for use with a different fuel without securing reapproval from the code official.

1301.4 Fuel tanks, piping, fittings and valves. The tank, piping, fittings and valves for *appliances* burning oil shall be installed in accordance with the requirements of this chapter. Where an oil burner is served by a tank, any part of which is above the level of the burner inlet connection and where the fuel supply line is taken from the top of the tank, an *approved* antisiphon valve or other siphon-breaking device shall be installed in lieu of the shutoff valve.

1301.5 Tanks abandoned or removed. All exterior above-grade fill piping shall be removed when tanks are abandoned or removed. Tank abandonment and removal shall be in accordance with Section 5704.2.13 of the *International Fire Code*.

SECTION 1302 MATERIAL

1302.1 General. Piping materials shall conform to the standards cited in this section.

1302.2 Rated for system. All materials shall be rated for the operating temperatures and pressures of the system, and shall be compatible with the type of liquid.

1302.3 Pipe standards. Fuel oil pipe shall comply with one of the standards listed in Table 1302.3.

**TABLE 1302.3
FUEL OIL PIPING AND FITTINGS**

MATERIAL	STANDARD (see Chapter 15)
Copper or copper-alloy pipe and fittings	ASTM B42; ASTM B43; ASTM B302; ASTM F3226
Copper or copper-alloy tubing and fittings (Type K, L or M)	ASME B16.51; ASTM B75; ASTM B88; ASTM B280; ASTM F3226
Labeled pipe	(See Section 1302.4)
Nonmetallic pipe	ASTM D2996
Steel and stainless steel pipe and fittings	ASTM A53; ASTM A106; A312/A312M; ASTM F3226
Steel and stainless steel tubing and fittings	ASTM A254; A269/A269M; ASTM A539; ASTM F3226

1302.4 Nonmetallic pipe. Nonmetallic pipe shall be *listed* and *labeled* as being acceptable for the intended application for flammable and combustible liquids. Nonmetallic pipe shall be installed only outdoors, underground.

1302.5 Fittings and valves. Fittings and valves shall be *approved* for the piping systems, and shall be compatible with, or shall be of the same material as, the pipe or tubing.

1302.6 Bending of pipe. Pipe shall be *approved* for bending. Pipe bends shall be made with *approved equipment*. The bend shall not exceed the structural limitations of the pipe.

1302.7 Pumps. Pumps that are not part of an *appliance* shall be of a positive-displacement type. The pump shall automatically shut off the supply when not in operation. Pumps shall be *listed* and *labeled* in accordance with UL 343.

SECTION 1305 FUEL OIL SYSTEM INSTALLATION

1305.1 Size. The fuel oil system shall be sized for the maximum capacity of fuel oil required. The minimum size of a supply line shall be 3/8-inch (9.5 mm) inside diameter nominal pipe or 3/8-inch (9.5 mm) outside diameter tubing. The minimum size of a return line shall be 1/4-inch (6.4 mm) inside diameter nominal pipe or 5/16-inch (7.9 mm) outside diameter tubing. Copper tubing shall have 0.035-inch (0.9 mm) nominal and 0.032-inch (0.8 mm) minimum wall thickness.

1305.2 Protection of pipe, equipment and appliances. Fuel oil pipe, *equipment* and *appliances* shall be protected from physical damage.

1305.2.1 Flood hazard. Fuel oil pipe, *equipment* and *appliances* located in flood hazard areas shall be located above the elevation required by Section 1612 of the *International Building Code* for utilities and attendant equipment or shall be capable of resisting hydrostatic and hydrodynamic loads and stresses, including the effects of buoyancy, during the occurrence of flooding up to such elevation.

1305.3 Supply piping. Supply piping shall connect to the top of the fuel oil tank. Fuel oil shall be supplied by a transfer pump or automatic pump or by other *approved* means.

Exception: This section shall not apply to inside or above-ground fuel oil tanks.

1305.4 Return piping. Return piping shall connect to the top of the fuel oil tank. Valves shall not be installed on return piping.

1305.5 System pressure. The system shall be designed for the maximum pressure required by the fuel-oil-burning *appliance*. Air or other gases shall not be used to pressurize tanks.

1305.6 Fill piping. A fill pipe shall terminate outside of a building at a point not less than 2 feet (610 mm) from any building opening at the same or lower level. A fill pipe shall terminate in a manner designed to minimize spilling when the filling hose is disconnected. Fill opening shall be equipped with a tight metal cover designed to discourage tampering.

[W] 1305.7 Vent piping. Liquid fuel vent pipes shall terminate outside of buildings at a point not less than ~~((2 feet (610 mm)))~~ 5 feet measured ~~((vertically or horizontally))~~ from any building opening. Outer ends of vent pipes shall terminate in a weatherproof vent cap or fitting or be provided with a weatherproof hood. Vent caps shall have a minimum free open area equal to the cross-sectional area of the vent pipe and shall not employ screens finer than No. 4 mesh. Vent pipes shall terminate sufficiently above the ground to avoid being obstructed with snow or ice. Vent pipes from tanks containing heaters shall be extended to a location where oil vapors discharging from the vent will be readily diffused. If the static head with a vent pipe filled with oil exceeds 10 pounds per square inch (psi) (69 kPa), the tank shall be designed for the maximum static head that will be imposed.

Liquid fuel vent pipes shall not be cross connected with fill pipes, lines from burners or overflow lines from auxiliary tanks.

Exception: Liquid fuel vent pipes may terminate outside the building at a point not less than 2 feet from the fuel oil equipment combustion exhaust outlet.

SECTION 1306 OIL GAUGING

1306.1 Level indication. Tanks in which a constant oil level is not maintained by an automatic pump shall be equipped with a method of determining the oil level.

1306.2 Test wells. Test wells shall not be installed inside buildings. For outdoor service, test wells shall be equipped with a tight metal cover designed to discourage tampering.

1306.3 Inside tanks. The gauging of inside tanks by means of measuring sticks shall not be permitted. An inside tank provided with fill and vent pipes shall be provided with a device to indicate either visually or audibly at the fill point when the oil in the tank has reached a predetermined safe level.

1306.4 Gauging devices. Gauging devices such as liquid level indicators or signals shall be designed and installed so that oil vapor will not be discharged into a building from the liquid fuel supply system. Liquid-level indicating gauges shall comply with UL 180.

1306.5 Gauge glass. A tank used in connection with any oil burner shall not be equipped with a glass gauge or any gauge that, when broken, will permit the escape of oil from the tank.

SECTION 1307 FUEL OIL VALVES

1307.1 Building shutoff. A shutoff valve shall be installed on the fuel-oil supply line at the entrance to the building. Inside or above-ground tanks are permitted to have valves installed at the tank. The valve shall be capable of stopping the flow of fuel

CHAPTER 14

SOLAR THERMAL SYSTEMS

User note:

About this chapter: Chapter 14 addresses solar thermal systems, not photovoltaic systems. The provisions are intended to protect property and life from the hazards associated with high-temperature liquids, pressurized systems and toxic fluids. There are also provisions to protect the building structure and the solar thermal system components from damage.

SECTION 1401 GENERAL

[S] **1401.1 Scope.** This chapter shall govern the design, construction, installation, *alteration* and repair of solar thermal systems, *equipment* and *appliances* intended to utilize solar energy for space heating or cooling, domestic hot water heating, swimming pool heating or process heating. Photovoltaic solar systems shall be installed in accordance with the *International Building Code* and Article 690 of the *Seattle Electrical Code*. Systems interconnected to the electric grid shall comply with additional requirements of Seattle City Light.

Note: See the *Seattle Boiler and Pressure Vessel Code* for regulations applicable to boilers and pressure vessels, and the *Seattle Plumbing Code* for regulations applicable to water heaters.

[S] **1401.2 Potable water supply.** Potable water supplies to solar systems shall be protected against contamination in accordance with the (~~*International*~~) *Seattle Plumbing Code*.

Exception: Where all solar system piping is a part of the potable water distribution system, in accordance with the requirements of the (~~*International*~~) *Seattle Plumbing Code*, and all components of the piping system are *listed* for potable water use, cross-connection protection measures shall not be required.

1401.3 Heat exchangers. Heat exchangers used in domestic water-heating systems shall be *approved* for the intended use. The system shall have adequate protection to ensure that the potability of the water supply and distribution system is properly safeguarded.

1401.4 Solar thermal equipment and appliances. Solar thermal *equipment* and *appliances* shall conform to the requirements of this chapter and ICC 900/SRCC 300. Solar thermal systems shall be *listed* and *labeled* in accordance with ICC 900/SRCC 300 and shall be installed in accordance with the manufacturer's instructions and ICC 900/SRCC 300.

1401.4.1 Collectors and panels. Solar thermal collectors and panels shall be *listed* and *labeled* in accordance with ICC 901/SRCC 100.

SECTION 1402 DESIGN AND INSTALLATION

1402.1 General. The design and installation of solar thermal systems shall comply with Sections 1402.1 through 1402.8. Solar thermal systems shall be *listed* and *labeled* in accordance with ICC 900/SRCC 300 and shall be installed in accordance with the manufacturer's instructions and ICC 900/SRCC 300.

1402.2 Access. Access shall be provided to solar thermal *equipment* for maintenance. Solar thermal systems and appurtenances shall not obstruct or interfere with the operation of any doors, windows or other building components requiring operation or access. Roof-mounted solar thermal *equipment* shall not obstruct or interfere with the operation of roof-mounted *equipment*, *appliances*, chimneys, roof hatches, smoke vents, skylights and other roof penetrations and openings.

1402.3 Pressure and temperature. Solar thermal system components containing pressurized fluids shall be protected against pressures and temperatures exceeding design limitations with pressure and temperature relief valves or pressure relief valves. System components shall have a working pressure rating of not less than the setting of the pressure relief device.

[S] **1402.3.1 Relief device.** Each section of the system in which excessive pressures are capable of developing shall have a relief device located so that a section cannot be valved off or otherwise isolated from a relief device. Relief valves shall comply with the requirements of (~~Section 1006.6~~) the *Seattle Boiler and Pressure Vessel Code*. For indirect solar systems, pressure relief valves in solar loops shall also comply with ICC 900/SRCC 300.

1402.3.2 Vacuum. System components that might be subjected to a vacuum while in operation or during shutdown shall be designed to withstand such vacuum or shall be protected with vacuum relief valves.

[S] **1402.8.3 Piping.** Potable piping shall be installed in accordance with the *International Plumbing Code*. Hydronic piping shall be installed in accordance with Chapter ((40)) 12 of this code. Mechanical system piping shall be supported in accordance with Section 305.

1402.8.3.1 Piping insulation. Piping shall be insulated in accordance with the requirements of the *International Energy Conservation Code*. Exterior insulation shall be protected from degradation. The entire solar loop shall be insulated. Where split-style insulation is used, the seam shall be sealed. Fittings shall be fully insulated. Insulation shall comply with Section 1204.1.

Exceptions:

1. Those portions of the piping that are used to help prevent the system from overheating shall not be required to be insulated.
2. Those portions of piping that are exposed to solar radiation, made of the same material as the solar collector absorber plate and covered in the same manner as the solar collector absorber, or that are used to collect additional solar energy, shall not be required to be insulated.
3. Piping in solar thermal systems using unglazed solar collectors to heat a swimming pool shall not be required to be insulated.

1402.8.4 Heat exchangers. Heat exchangers used in domestic water-heating systems shall be approved for the intended use. The system shall have adequate protection to ensure that the potability of the water supply and distribution system is properly safeguarded.

1402.8.4.1 Double-wall heat exchangers. Heat exchangers utilizing a nonfood-grade fluid shall be separated from the potable water by double-wall construction. An air gap open to the atmosphere shall be provided between the two walls. The discharge location from the double-wall heat exchanger shall be visible.

1402.8.4.2 Single-wall heat exchangers. Food-grade fluids shall be used as the heat transfer fluid in singlewall heat exchangers.

1402.8.5 Water heaters and hot water storage tanks. Auxiliary water heaters, boilers and water storage tanks associated with solar thermal systems shall comply with Chapter 10 and ICC 900/SRCC 300.

1402.8.5.1 Hot water storage tank insulation. Hot water storage tanks shall be insulated and such insulation shall have an *R*-value of not less than R-12.5.

1402.8.5.2 Outdoor locations. Storage tanks and heating *equipment* installed in outdoor locations shall be designed for outdoor installation.

1402.8.5.3 Storage tank sensors. Storage tank sensors shall comply with ICC 900/SRCC 300.

1402.8.6 Solar loop. Solar loops shall be in accordance with Sections 1402.8.6.1 and 1402.8.6.2.

1402.8.6.1 Solar loop isolation. Valves shall be installed to allow the solar loop to be isolated from the remainder of the system.

1402.8.6.2 Drain and fill valve caps. Drain caps shall be installed on drain and fill valves.

[S] **1402.8.7 Expansion tanks.** Liquid single-phase solar energy systems shall be equipped with expansion tanks sized in accordance with ((Section 1009)) the *Seattle Boiler and Pressure Vessel Code*, except that additional expansion tank acceptance volume equal to the total volume of liquid contained in the installed solar collectors and piping above the collectors shall be included.

SECTION 1403 HEAT TRANSFER FLUIDS

1403.1 Flash point. The flash point of the heat transfer fluid utilized in a solar system shall be not less than 50°F (28°C) above the design maximum nonoperating (no-flow) temperature of the fluid attained in the collector.

1403.2 Heat transfer fluids. Heat transfer gases and liquids shall be rated to withstand the system's maximum design temperature under operating conditions without degradation. Heat transfer fluids shall be in accordance with ICC 900/SRCC 300.

1403.3 Food-grade additives. Any food-grade fluid used as a heat transfer fluid containing additives shall be third-party listed by an approved agency to the appropriate section of the Code of Federal Regulations, Title 21, Food and Drugs, Chapter 1, Food and Drug Administration, Parts 174–186.

1403.4 Toxicity. The use of toxic fluids shall comply with Title 15 of the Federal Hazardous Substances Act and Chapter 60 of the *International Fire Code*.

CHAPTER 15

REFERENCED STANDARDS

User note:

About this chapter: This code contains numerous references to standards that are used to provide requirements for materials and methods of construction. This chapter contains a comprehensive list of all standards that are referenced in this code. These standards, in essence, are part of this code to the extent of the reference to the standard. This chapter lists the standards that are referenced in various sections of this document.

The standards are listed herein by the promulgating agency of the standard, the standard identification, the effective date and title, and the section or sections of this document that reference the standard. The application of the referenced standards shall be as specified in Section ~~(402.8)~~ 103.5.

ACCA

Air Conditioning Contractors of America
2800 Shirlington Road, Suite 300
Arlington, VA 22206

ANSI/ACCA 1 Manual D—2016: Residential Duct Systems
601.4, 603.2

ANSI/ACCA 10 Manual SPS—2010 (RA 2017): HVAC Design for Swimming Pools and Spas
403.2.1

ANSI/ASHRAE/ACCA 183—2007 (reaffirmed 2014): Peak Cooling and Heating Load Calculations in Buildings Except Low-rise Residential Buildings
312.1

AHAM

AHAM Association of Home Appliance Manufacturers
1111 19th St. N.W., #402
Washington, D.C. 20036

[W] AHAM-Certified Range Hood Directory
403.4.7.3.1

[W] HRH-2 Household Range Hoods
403.4.7.3.1

AHRI

Air-Conditioning, Heating & Refrigeration Institute
2311 Wilson Blvd., Suite 400
Arlington, VA 22201

700—2017: with Addendum 1: Specifications for Refrigerants
1102.2.2.3

AMCA

Air Movement and Control Association International
30 West University Drive
Arlington Heights, IL 60004

230—15: Laboratory Methods of Testing Air Circulating Fans for Rating and Certification
930.1

ANSI/AMCA 210—16/ANSI/ASHRAE 51—16: Laboratory Methods of Testing Fans for Aerodynamic Performance Rating
403.3.2.5

ANSI/AMCA 550—15 (Rev. 09/18): Test Method for High Velocity Wind Driven Rain Resistant Louvers
401.5, 501.3.2

REFERENCED STANDARDS

ANCE

[W] UL/CSA/ANCE 60335-2-40-2019 Household and Similar Electrical Appliances—Safety—Part 2-40: Particular Requirements for Electrical Heat Pumps, Air Conditioners and Dehumidifiers
Table 1101.2

ANSI

American National Standards Institute
25 West 43rd Street, 4th Floor
New York, NY 10036

ANSI Z21.1—2016/CSA 1.1—2016: Household Cooking Gas Appliances
505.2

Z21.8—1994 (R2017): Installation of Domestic Gas Conversion Burners
919.1

ASHRAE

ASHRAE
1791 Tullie Circle NE
Atlanta, GA 30329

15—2019: Safety Standard for Refrigeration Systems
1101.6, 1105.8, 1108.1

34—2019: Designation and Safety Classification of Refrigerants
202, 1102.2.1, 1103.1

62.1—2019: Ventilation for Acceptable Indoor Air Quality
401.2, 403.3.1.1.2.3.2

[W] 62.2—2019: Ventilation and Acceptable Indoor Air Quality in Low-Rise Residential Buildings
401.4, 403.4, 403.4.7.3.3, 403.4.11

90.1—2016: Energy Standard for Buildings Except Low-rise Residential Buildings
401.2

170—2017: Ventilation of Health Care Facilities
407

180—2018: Standard Practice for Inspection and Maintenance of Commercial Building HVAC Systems
102.3

ANSI/AMCA 210—ANSI/ASHRAE 51—16: Laboratory Methods of Testing Fans for Aerodynamic Performance Rating
403.3.2.4

ASHRAE—2017: ASHRAE Handbook of Fundamentals
603.2

ASME

American Society of Mechanical Engineers
Two Park Avenue
New York, NY 10016-5990

A112.4.1—2009 (R2019): Water Heater Relief Valve Drain Tubes
1006.6

B1.1—2003: Unified Inch Screw Threads, UN and UNR Thread Form
1108.3.4

B1.13M—2006: Metric Screw Threads: M Profile
1108.3.4

B1.20.1—2013(R2018): Pipe Threads, General Purpose (Inch)
1203.3.5, 1303.3.3

B1.20.3—1976: Dryseal Pipe Threads, Inch
1108.3.4

B16.3—2016: Malleable Iron Threaded Fittings, Classes 150 & 300
Table 1202.5

ASME—continued

- B16.5—2017: Pipe Flanges and Flanged Fittings NPS 1/2 through NPS 24**
Table 1202.5
- B16.9—2019: Factory-made Wrought Steel Butt welding Fittings**
Table 1202.5
- B16.11—2016: Forged Fittings, Socket-welding and Threaded**
Table 1202.5
- B16.15—2018: Cast Alloy Threaded Fittings: Classes 125 and 250**
Table 1202.5
- B16.18—2018: Cast Copper Alloy Solder Joint Pressure Fittings**
513.13.1, Table 1202.5
- B16.22—2018: Wrought Copper and Copper Alloy Solder Joint Pressure Fittings**
513.13.1, Table 1202.5
- B16.24—2016: Cast Copper Alloy Pipe Flanges and Flanged Fittings: Class 150, 300, 400, 600, 900, 1500 and 2500**
Table 1202.5
- B16.26—2018: Cast Copper Alloy Fittings for Flared Copper Tubes**
Table 1202.5
- B16.28—1994: Wrought Steel Butt welding Short Radius Elbows and Returns**
Table 1202.5
- B16.50—2018: Wrought Copper and Copper Alloy Braze-joint Pressure Fittings**
Table 1107.5
- B16.51—2018: Copper and Copper Alloy Press-connect Pressure Fittings**
Table 1202.5
- B31.5—2010: Refrigeration Piping and Heat Transfer Components**
1107.5.1
- B31.5—2019: Refrigeration Piping and Heat Transfer Components**
1107.1
- B31.9—2020: Building Services Piping**
1201.3
- ~~((BPVC—2019: ASME Boiler & Pressure Vessel Code—07 Edition
1003.1, 1004.1, 1009.2, 1011.1))~~
- ~~((CSD-1—2018: Controls and Safety Devices for Automatically Fired Boilers
1004.1))~~

ASSE

ASSE International
18927 Hickory Creek Drive, Suite 220
Mokena, IL 60448

- 1017—2009: Performance Requirements for Temperature Actuated Mixing Valves for Hot Water Distribution Systems**
1002.2.2
- 1061—2015: Performance Requirements for Push Fit Fittings**
Table 1202.5
- 1079—2005: Performance Requirements for Dielectric Pipe Unions**
1108.1.1

ASSP

American Society of Safety Professionals
520 N. Northwest Highway
Park Ridge, IL 60068

- ANSI/ASSP Z359.1—2020: The Fall Protection Code**
304.11

REFERENCED STANDARDS

ASTM—continued

- D2564—2012(2018): Specification for Solvent Cements for Poly (Vinyl Chloride) (PVC) Plastic Piping Systems**
1203.3.4
- D2657—2007(2015): Standard Practice for Heat Fusion Joining of Polyolefin Pipe and Fittings**
Table 1210.5
- D2683—14: Specification for Socket-type Polyethylene Fittings for Outside Diameter-controlled Polyethylene Pipe and Tubing**
Table 1210.5, 1210.6.6.1
- D2737—12a: Standard Specification for Polyethylene (PE) Plastic Tubing**
Table 1210.4
- D2846/D2846M—2017BE1: Specification for Chlorinated Poly (Vinyl Chloride) (CPVC) Plastic Hot- and Cold-water Distribution Systems**
Table 1202.4, Table 1202.5, 1203.3.4, Table 1210.4
- D2996—2017: Specification for Filament-wound Fiberglass (Glass Fiber Reinforced Thermosetting Resin) Pipe**
Table 1302.3
- D3035—15: Specification for Polyethylene (PE) Plastic Pipe (DR-PR) Based on Controlled Outside Diameter**
Table 1210.4
- D3261—2016: Specification for Butt Heat Fusion Polyethylene (PE) Plastic Fittings for Polyethylene (PE) Plastic Pipe and Tubing**
Table 1210.5, 1210.6.6.1
- D3278—96(2011): Test Methods for Flash Point of Liquids by Small Scale Closed-cup Apparatus**
202
- D3309—96a(2002): Specification for Polybutylene (PB) Plastic Hot- and Cold-water Distribution Systems**
Table 1202.4
- E84—2018B: Standard Test Method for Surface Burning Characteristics of Building Materials**
202, 510.8, 602.2, 602.2.1, 602.2.1.6, 602.2.1.7, 604.3, 1204.1
- E119—2018B: Test Method for Fire Tests of Building Construction and Materials**
607.2.1, 607.5.2, 607.5.5, 607.6.1
- E136—2019: Standard Test Method for Assessing Combustibility of Materials Using a Vertical Tube Furnace at 750 Degrees C**
202
- E814—2013A(2017): Standard Test Method for Fire Tests of Penetration Firestop Systems**
506.3.11.2, 506.3.11.3
- E1509—2012(2017): Specification for Room Heaters, Pellet Fuel-burning Type**
904.1
- E2231—2018: Standard Practice for Specimen Preparation and Mounting of Pipe and Duct Insulation Materials to Assess Surface Burning Characteristics**
604.3, 1204.1
- E2336—16: Standard Test Methods for Fire Resistive Grease Duct Enclosure Systems**
506.3.6, 506.3.11.2
- [W] E3087-18: Standard Test Method for Measuring Capture Efficiency of Domestic Range Hoods**
403.4.7.3.2, Table 403.4.7.3.2
- F437—15: Specification for Threaded Chlorinated Poly (Vinyl Chloride) (CPVC) Plastic Pipe Fittings, Schedule 80**
Table 1210.5
- F438—2017: Specification for Socket Type Chlorinated Poly (Vinyl Chloride) (CPVC) Plastic Pipe Fittings, Schedule 40**
Table 1202.5, Table 1210.5
- F439—13: Specification for Socket Type Chlorinated Poly (Vinyl Chloride) (CPVC) Plastic Pipe Fittings, Schedule 80**
Table 1202.5, Table 1210.5
- F441/F441M—15: Specification for Chlorinated Poly (Vinyl Chloride) (CPVC) Plastic Pipe, Schedules 40 and 80**
Table 1202.4, Table 1210.4
- F442/F442M—13e1: Specification for Chlorinated Poly (Vinyl Chloride) (CPVC) Plastic Pipe (SDR-PR)**
Table 1202.4, Table 1210.4
- F493—14: Specification for Solvent Cements for Chlorinated Poly (Vinyl Chloride) (CPVC) Plastic Pipe and Fittings**
1203.3.4
- F714—13: Standard Specification for Polyethylene (PE) Plastic Pipe (SDR-PR) Based on Outside Diameter**
Table 1210.4

CSA—continued

B137.9—17: Polyethylene/Aluminum/Polyethylene (PE-AL-PE) Composite Pressure-pipe Systems

Table 1202.4, Table 1210.4, Table 1210.5

B137.10—17: Cross-linked Polyethylene/Aluminum/Cross-linked Polyethylene (PEX-AL-PEX) Composite Pressure-pipe Systems

Table 1202.4

B137.11—17: Polypropylene (PP-R) Pipe and Fittings for Pressure Applications

Table 1210.4, Table 1210.5

B137.18—17: Polyethylene of Raised Temperature Resistance (PE-RT) Tubing Systems for Pressure Applications

Table 1202.4, Table 1202.5, Table 1210.5

C22.2 No. 218.1—13(R2017): Spas, Hot Tubs and Associated Equipment

916.1

C22.2 No. 236—15: Heating and Cooling Equipment

916.1

DOL

U.S. Department of Labor Occupational Safety and Health Administration
c/o Superintendent of Documents U.S. Government Printing Office
Washington, DC 20402-9325

29 CFR Part 1910.1000 (2015): Air Contaminants

502.6

29 CFR Part 1910.1025 (2015): Toxic and Hazardous Substances

502.19

FDA

U.S. Food and Drug Administration
10903 New Hampshire Avenue
Silver Springs, MD 20993

FDA Title 15: Federal Hazardous Substances Act

1403.4

FDA Title 21: Code of Federal Regulations, Title 21, Food and Drugs, Chapter 1, Food and Drug Administration, Parts 174–186 (revised as of April 1, 2015)

1403.3

FS

Federal Specifications* General Services Administration
7th & D Streets Specification Section, Room 6039
Washington, DC 20407

WW-P-325B (1976): Pipe, Bends, Traps, Caps and Plugs; Lead (for Industrial Pressure and Soil and Waste Applications)

Table 1202.4

*Standards are available from the Supt. of Documents, U.S. Government Printing Office, Washington, DC 20402-9325

HVI

Home Ventilating Institute*
1740 Dell Range Blvd., Suite H
PMB 450
Cheyenne, WY 82009

[W] HVI Publication 911: Certified Home Ventilating Product Directory

403.4.7.3.4

[W] HVI 915-2020: Procedure for Loudness Testing of Residential Fan Products

403.4.6.1, 403.4.6.2, 403.4.7.2

[W] HVI 916-2020: Air Flow Test Procedure

403.4.6.1, 403.4.6.2, 403.4.7.2

[W] HVI 920-2020: Product Performance Certification Procedure Including Verification and Challenge

403.4.6.1, 403.4.6.2, 403.4.7.2

NAIMA

North American Insulation Manufacturers Association
11 Canal Center Plaza, Suite 103
Alexandria, VA 22314

AH116—09: Fibrous Glass Duct Construction Standards
603.5, 603.9

NBBI

National Board of Boiler and Pressure Vessel Inspectors
1055 Crupper Avenue
Columbus, OH 43229-1183

NBIC—2017: National Board Inspection Code, Part 3
1003.3

NFPA

National Fire Protection Association
1 Batterymarch Park
Quincy, MA 02169-7471

2—20: Hydrogen Technologies Code
502.16.1

30A—21: Code for Motor Fuel-dispensing Facilities and Repair Garages
304.6

31—20: Standard for the Installation of Oil-burning Equipment
701.1, 801.2.1, 801.18.1, 801.18.2, 920.2, 922.1, 1308.1

37—18: Standard for the Installation and Use of Stationary Combustion Engines and Gas Turbines
915.1, 915.2

58—20: Liquefied Petroleum Gas Code
502.9.10

69—19: Standard on Explosion Prevention Systems
510.8.3

70—20: National Electrical Code
301.7, 306.3.1, 306.4.1, 511.1.1, 513.11, 513.12.2, 602.2.1.1, 927.2, 1104.2.2, 1106.3, 1402.8.1.4

72—19: National Fire Alarm and Signaling Code
606.3

80—19: Standard for Fire Doors and Other Opening Protectives
607.4.1.2

82—19: Incinerators and Waste and Linen Handling Systems and Equipment
601.1

85—19: Boiler and Combustion Systems Hazards Code
1004.1

91—20: Exhaust Systems for Air Conveying of Vapors, Gases, Mists and Noncombustible Particulate Solids
502.9.5.1, 502.17

92—18: Standard for Smoke Control Systems
513.7, 513.8

96—21: Standard for Ventilation Control and Fire Protection of Commercial Cooking Operations
507.1

99—21: Health Care Facilities Code
407.1

105—19: Standard for Smoke Door Assemblies and Other Opening Protectives
607.4.1.2

[W]110-22: Standard for Emergency and Standby Power Systems
915.3, 915.3.1, 915.3.2

[W]111-22: Standard on Stored Electrical Energy Emergency and Standby Power Systems
915.3, 915.4

REFERENCED STANDARDS

UL—continued

- 641—2010: Type L Low-temperature Venting Systems—with revisions through April 2018**
802.1
- 705—2017: Power Ventilators—with revisions through October 2018**
504.5
- 710—2012: Exhaust Hoods for Commercial Cooking Equipment—with revisions through June 2018**
507.1
- 710B—2011: Recirculating Systems—with revisions through August 2014**
507.1, 507.2
- 723—2018: Surface Burning Characteristics of Building Materials**
510.8, 602.2, 602.2.1, 602.2.1.6, 602.2.1.7, 604.3, 1204.1
- 726—95: Oil-fired Boiler Assemblies—with revisions through October 2013**
916.1, 1004.1
- 727—2018: Oil-fired Central Furnace**
918.1
- 729—2003: Oil-fired Floor Furnaces—with revisions through November 2016**
910.1
- 730—2003: Oil-fired Wall Furnaces—with revisions through November 2016**
909.1
- 731—2018: Oil-fired Unit Heaters**
920.1
- 732—2018: Oil-fired Storage Tank Water Heaters**
1002.1
- 737—2011: Fireplace Stoves**
905.1
- 762—2013: Outline of Investigation for Power Ventilators for Restaurant Exhaust Appliances**
506.5.1
- 791—2006: Residential Incinerators—with revisions through November 2014**
907.1
- 834—04: Heating, Water Supply and Power Boilers Electric—with revisions through September 2018**
1004.1
- 842—2015: Valves for Flammable Fluids—with revisions through May 2015**
1307.1
- 858—2014: Household Electric Ranges—with revisions through June 2018**
917.1
- [W] 864—2014: Control Units and Accessories for Fire Alarm Systems—with revisions through October 2018**
513.12, 606.2.2
- 867—2011: Electrostatic Air Cleaners—with revisions through August 2018**
605.2
- 875—2009: Electric Dry Bath Heater—with revisions through September 2017**
914.2
- 896—1993: Oil-burning Stoves—with revisions through November 2016**
917.1, 922.1
- 900—2015: Air Filter Units**
605.2
- 907—2016: Fireplace Accessories**
902.2
- 923—2013: Microwave Cooking Appliances—with revisions through July 2017**
917.1
- 959—2010: Medium Heat Appliance Factory-built Chimneys—with revisions through June 2014**
805.6
- 971A—2006: Outline of Investigation for Metallic Underground Fuel Pipe**
1302.9

UL—continued

2221—2010: Tests of Fire Resistive Grease Duct Enclosure Assemblies

506.3.11.3

2518—2016: Air Dispersion Systems

603.17

2523—2009: Solid Fuel-fired Hydronic Heating Appliances, Water Heaters, and Boilers—with revisions through March 2018

1002.1, 1004.1

2846—2014: Fire Test of Plastic Water Distribution Plumbing Pipe for Visible Flame and Smoke Characteristics—with revisions through December 2016

602.2.1.7

8782—17: Outline of Investigation for Pollution Control Units for Commercial Cooking

506.5.2

■ [W] **UL/CSA/~~ANCE~~ 60335-2-40—((47)) 2019: Household and Similar Electrical Appliances—Safety—Part 2-40: Particular Requirements for Electrical Heat Pumps, Air-Conditioners and Dehumidifiers**

908.1, 916.1, 918.1, 918.2, Table 1101.2

■ **UL/CSA 60335-2-89—17: Household and Similar Electrical Appliances—Safety—Part 2-89: Particular Requirements for Commercial Refrigerating Appliances with an Incorporated or Remote Refrigerant Unit or Compressor**

Table 1101.2